



National
Coaching
Certification
Program

*Fencing
Armourer and Competition
Module*



CANADIAN FENCING FEDERATION

NATIONAL COACHING CERTIFICATION

LEVEL IV : ARMOURER AND COMPETITION

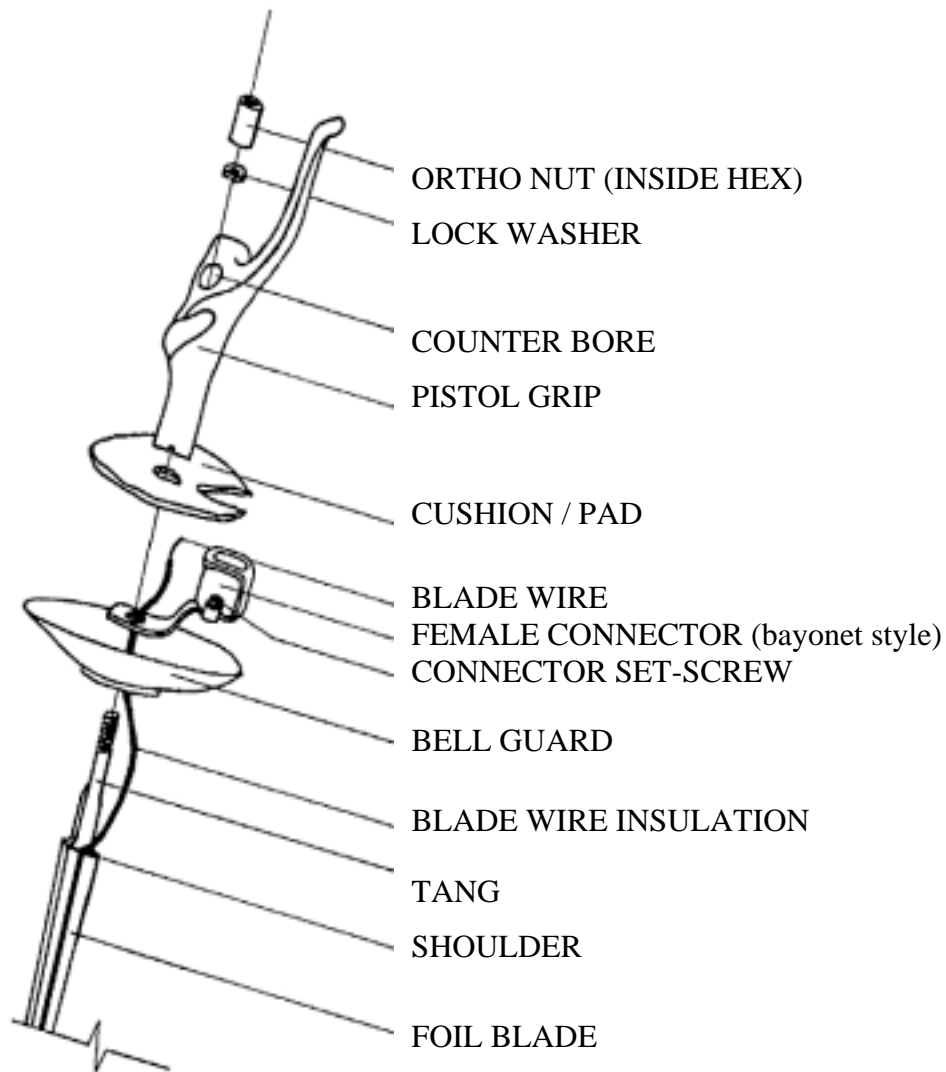

by

Christopher Ram

CANADIAN FENCING FEDERATION

Table of contents

Page

	Task #1- Armourer	1
I.	Personal equipment	4
1.1	Introduction	4
1.2	Weapons	4
1.2.1	Wiring blade	4
1.2.2	Weapon assembly	15
1.2.3	Weapon Maintenance and Repair	24
1.2.3.1	Foil Maintenance	24
1.2.3.2	Foil repairs	25
1.2.3.3	Epee Maintenance	28
1.2.3.4	Epee Repairs	30
1.2.3.5	Repair and Maintenance of Body Wires	32
1.2.3.6	Sabre Repair and Maintenance	35
1.3	Maintenance of Other Equipment	36
1.3.1	Fencing whites	36
1.3.2	Masks	37
1.3.3	Metallic Foil and Sabre Plastrons	38
1.3.4	Note on FIE certified equipment	39
1.3.5	Safety procedures	39
II.	Judging apparatus	40
2.1	Introduction	40
2.2	The Scoring Machine	41
2.3	The Piste Cables	45
2.4	The Reels	46
2.4.1	The horizontal axis reel	48
2.4.2	The vertical axis reel	51
2.5	Overhead cable retrieval apparatus	54
2.6	Troubleshooting on the Piste	56
2.6.1	General notes	56
2.6.2	Troubleshooting foil apparatus	57
2.6.3	Troubleshooting epee apparatus	59
2.6.4	Intermittent and multiple faults	60

Task #2 - Competition 61

I. Preliminary Considerations 65

1.1	The organizing committee	65
1.1.1	Chairman of the organizing committee	66
1.1.2	Registrations	66
1.1.3	Apparatus	66
1.1.4	Directoire technique	66
1.1.5	Treasurer/Accountant	67
1.1.6	Venue	67
1.1.7	Fundraising	67
1.1.8	Public relations	68
1.2	The Schedule of Events	68
1.3	The Budget	69
1.3.1	Revenue sources	70
1.3.2	Costs	70
1.4	The Entry Form	71
1.5	The Sanction	72
1.6	The Venue	73
1.6.1	Rental of the venue	73
1.6.2	Choosing the venue	73
1.6.3	Preparing a floor plan	76
1.7	Officials	82
1.7.1	Number of officials	82
1.7.2	Competence	83
1.7.3	Minor officials	84
1.8	Awards	85

II.	Running the Competition	86
2.1	Setting up the competition	86
2.1.1	Delivery and inventory of scoring apparatus	86
2.1.2	Laying and stretching pistes	87
2.1.3	Setting up other equipment	94
2.1.4	Setting up the repair shop	95
2.1.5	Setting up the directoire technique	96
2.2	Taking Registrations	97
2.2.1	Pre-registrations	97
2.2.2	On-site registrations	97
2.2.3	Closing registrations	98
2.2.4	Handling cash	99
2.3	Running the competition	100
2.3.1	Directoire technique	100
2.3.2	Determining format	101
2.3.3	Seeding	105
2.3.4	Staging the finals	109
2.3.5	Tabulation, recording and reporting results	109
2.3.6	Apparatus	109
III.	Post Competition Matters	111
3.1	Accounting	111
3.2	Dismantling the Competition	115
3.3	Public Relations	116

Table of illustrations

Fig.	Title	Page
1A	Foil point (Leon Paul)	7
1B	Foil point (Uhlman)	8
1C	Foil point (Allstar/Prieur)	8
2	Epee point	9
3	Testing the epee point	11
4	Correct curvature for gluing of blade wires	12
5	Sample design for blade-wiring jig	13
6	Setting blade for right or left-handed fencers	17
7	Fitting pistol-grips	18
8	Complete weapon	20
9	Epee scoring and ground circuits	22
10	Epee hit registration (schematic)	22
10B	Eccentric mounting (Epee bell guards)	31
11	Foil scoring and target circuit	33
12	Foil hit registration (schematic)	34
13	Typical FIE certification marks	39
14	Horizontal axis reel	49
15	Vertical axis reel	52
16	Bungie cord apparatus (overhead)	54
17	Bungie cord apparatus (floor)	55
18	Completed floor plan	77
19	Common piste arrangements (interlocking method)	79
20	Common piste arrangements (back to back method)	80
21	Sample equipment inventory sheet	86
22	Stretching piste equipped with stretching hardware	89
23	Stretching piste not equipped with stretching hardware	91
24	Sample pool card	98
25	Competition formats (preliminary)	104
26	Competition formats (to final)	106
27	Sample balance sheet	112
28	Sample of petty cash return statement	113
29	Sample financial statement	114

TASK #1- ARMOURER

Candidates must become proficient in the maintenance, inspection; and repair of the fencers' personal equipment and judging apparatus in practice (sale) and competition situations.

Need to know 

Personal Equipment

1. Candidates must become competent in the wiring and assembly of foil and epee blades from their component parts.
2. Candidates must become competent in assembling all three weapons, and in performing any adjustments appropriate for individual fencers.
3. Candidates must become familiar with the regulations as they pertain to all three weapons, and be able to administer a proper control to ensure compliance with those regulations.
4. Candidates must become familiar with the regulations and safety standards as they pertain to other personal equipment, including masks, clothing, gloves and other protective equipment, so as to be able to:
 - administer a proper control under the regulations,
 - conduct adequate safety inspections of all equipment, and,
 - effect any repairs necessary to restore equipment to compliance with the regulations and/or safe operating standards.
5. Candidates must become familiar with the regulations governing the metallic plastron for electrical foil and sabre fencing so as to be able to:
 - administer a proper control under the regulations, and,
 - carry out any repairs required to restore a defective plastron to compliance with the regulations
6. Candidates must become familiar with the components and circuitry of bodywires used for electric foil, epee and sabre fencing so as to be able to control and effect any necessary repairs.
7. Candidates must develop an adequate personal standard of safety governing all procedures for the inspection, maintenance, handling and storage of personal fencing equipment, and the ability to instil such a standard in novice fencers and competitors in the context of the lesson, practice, and competition environments.

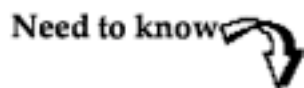

Judging Apparatus

1. Candidates must become familiar with the basic layout and assembly of judging apparatus for practice and competition usage.
2. Candidates must become familiar with the basic circuitry used to judge foil, epee, and sabre, and the differences between them.
3. Candidates must become familiar with the diagnosis and repair of problems in reels and overhead cable retrieval systems so as to be able to carry out repairs in practice and competition environments.
4. Candidates must become familiar with the storage, installation, maintenance and repair of metallic mesh fencing pistes and their general usage in practice and competition environments.
5. Candidates must become familiar with the storage, basic set-up and maintenance, and electrical safety procedures for judging machines.
6. Candidates must become competent at isolating and diagnosing electrical faults in a fully-assembled piste during the conduct of a fencing bout, and be able to effect timely and adequate repairs.
7. Candidates must develop sufficient basic electrical knowledge to be able to understand and apply electrical safety principles to practice and competition situations.

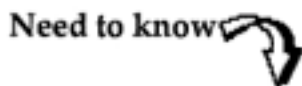

Safety Procedures

1. Candidates must become familiar with the current Regulations for Competitions as they apply to basic safety standards for equipment in all fencing situations.
2. Candidates must become familiar with the control and safety inspection of masks and demonstrate an adequate procedure for disposing of masks determined to be unsafe.
3. Candidates must become familiar with the basic procedures to be followed in conducting a safety inspection of all other personal equipment, and with any repair procedures necessary to restore such equipment to a safe operating condition.
4. Candidates must develop a basic safety procedure relating to the storage and use of all equipment in practice and competitive environments, and a regular inspection procedure to ensure that basic standards are maintained at all times.

TASK #1 DELIVERY

1. All candidates will be required to pre-read prepared course materials.
2. A teaching/evaluation clinic will be conducted under the following conditions:
 - a lecture/demonstration format will be used,
 - a maximum of 10 students will be permitted per clinic,
 - 4 hours each will be devoted to personal and judging equipment,
 - 4 hours will be held in reserve, and,
 - 4 hours will be allocated to evaluation.
3. A "mentor" or individual instructor may be assigned to each candidate where requested, at the discretion of the examiners.

TASK #1 EVALUATION

1. There will be a one hour short-answer or multiple-choice examination based on the pre-read course materials, to be administered and graded at the same time as the teaching clinic is held, if possible. This examination may be administered at or prior to the beginning of the clinic.
2. There will be a practical examination involving the diagnosis and repair of equipment faults which may be conducted in either a club or competition environment, at the examiner's option. This may involve the use of a complete fencing piste and equipped fencers or a simulation thereof.

Candidates may be required to isolate mechanical or electrical faults at any point in the system, to effect adequate repairs to any faults so isolated, to demonstrate adequate control of the piste during diagnostic or repair procedures, to demonstrate knowledge of the equipment regulations and proficiency with equipment control procedures, or any combination of the above.

Candidates will be graded according to the speed and efficiency with which procedures are carried out, the correctness of any analysis of problems encountered or knowledge of the regulations or procedures, and workmanship or the quality of any repairs carried out.

I - PERSONAL EQUIPMENT

1.1 INTRODUCTION

Any coach or competitive fencer will have developed certain basic expertise in the purchase, assembly, and maintenance of personal fencing equipment. The purpose of this chapter is to provide additional detail, and to suggest standard procedures and techniques for use by the coach and for passing on to students as their general knowledge of the sport develops.

Each individual student must be made responsible for his own equipment at all times', and most will have to be reminded of this responsibility frequently. Personal equipment maintenance should be taught as an essential part of the sport, rather than being relegated to the club technician or done by the coach himself. No competitor can be expected to perform at his best capacity without a thorough understanding of the equipment he uses: what it will (and will not) do, what happens when it malfunctions, and how to make the necessary repairs. The materials in the following chapter should be used as a guide by coaches to provide fencers with standard and consistent maintenance procedures, and to set a minimum standard of workmanship, particularly where safety is a concern.

1.2 WEAPONS

1.2.1 WIRING BLADES

It is essential that all coaches, and most advanced competitors, be able to wire their own foil and epee blades. In addition to saving money, it ensures a much higher quality of workmanship than is usually available commercially, and allows the fencer or club to re-use blades after a wire has broken or separated. Good and consistent work procedures are essential at all stages, since a later malfunction can cause valuable work or practice time to be lost, or affect competitive results. Competitors at all levels of fencing must have confidence in their equipment, in their own repair skills, and in the repair skills of coaches and managers. Such confidence will only be developed through consistent and proper maintenance procedures.

1.2.1.1 Materials required

- | | |
|---|--|
| <input type="checkbox"/> electric foil /epee blades | <input type="checkbox"/> point springs |
| <input type="checkbox"/> point cartridges (barrels) | <input type="checkbox"/> glue or cement (cyanoacrylate or fast epoxy) |
| <input type="checkbox"/> foil / epee blade wires | <input type="checkbox"/> solvent (suitable for dissolving glue and de-greasing blades) |
| <input type="checkbox"/> foil / epee points | <input type="checkbox"/> wood sticks (for mixing glue and scouring blades) |
| <input type="checkbox"/> point screws | <input type="checkbox"/> paper towels or rags |

1. Regulations for Competitions, Chapter V, Article 16, ss. 1,2

1.2.1.2 Tools required

- safety glasses or other suitable eye protection
- 2 mm screwdriver for point screws
- small vise-grips or similar pliers (for tightening barrels)
- rod (3 mm × 50 mm for setting point wires)
- foil (500 g) or epee (750 g) test weight
- electrical tester with leads (alligator clips)
- stable workbench area with vise (min. 80 mm)
- jig for securing bent blades (see Fig. 5, page 13)
- utility knife (disposable blade type)
- 10" mill or bastard file
- small warding (key) file (to fit into foil blade grooves)
- 0.5/1.5 mm test gauges (epee)
- 15-17 mm depth spacer gauge (epee) (homemade)

1.2.1.3 Safety notes

The primary hazard involved in wiring blades is from injuries that can result from bent blades suddenly slipping from vises or jigs, or on occasion, breaking. A bent blade contains considerable energy, which can cause severe injuries if suddenly released, particularly if the point or broken end strikes an eye. For this reason, eye protection must be worn whenever blades are bent. In choosing safety glasses or a visor, make sure that these are comfortable enough to wear for long periods of work, and strong enough to withstand a substantial impact from the end of a broken blade. The hazard can be further reduced by designing wiring jigs to prevent blades from slipping out or being accidentally pulled out (see Fig. 5, page 13). If other persons are present while blades are being wired, they must also be equipped with eye protection, or kept at a safe distance. Blades should not be stored for any length of time in a bent position (24 hours is adequate for even slow epoxy glues to cure), and while they are bent, they should be stored away from work areas and out of the reach of children.

The other major concern arises from the use of volatile or toxic chemicals as adhesives or degreasing compounds. If acetone or a similar solvent is used, it should be confined to airtight containers wherever possible to minimise fumes (this also saves money by preventing evaporation), and all cleaning and gluing should be done in a well-ventilated environment. Generally, quantities of acetone used are small enough to avoid serious hazards, but less-volatile substitutes may be used for de-oiling blades and cleaning up glues if available. Even fairly small quantities of acetone (100 ml or so) may generate toxic fumes in a small room, if spilled. As with any volatile solvent, acetone should not be used or stored around open flames, including pilot lights, or where a risk of fire exists. Storage in small-volume fireproof containers away from residential areas and fire exits is recommended.

Epoxy cements provoke allergic reactions in some people, and exposure to the skin should be minimised. Fingers used to apply glue to wires should be cleaned as soon as possible, and before the glue begins to harden. If large numbers of blades are to be wired with epoxy, or if even low exposures cause skin irritation, vinyl or rubber medical gloves (available from surgical suppliers) should be used.

Cyanoacrylate glues ("Crazy Glue") will bond human skin, with painful and embarrassing results, and any skin contact must be avoided. If these become stuck on the skin, soaking the affected part in acetone for a few minutes will usually break the bond.

Eye protection should also be worn to protect against splashes when using or handling any of the above substances.

1.2.1.4 Procedure

1. Clean blades thoroughly. New blades come complete with a film of oil used to keep them from rusting in storage and transit. Glue will not stick to this film, so it must be completely removed. A good method is to soak the blades in acetone or a similar degreaser for several hours prior to beginning. A 115 cm length of copper tubing about 4 cm in diameter mounted vertically on the workbench with a cap soldered on the bottom makes a good soaking tank, and can be sealed at the top to limit evaporation.

When blades have been soaked, they should be scoured several times with a wooden stick to remove any oily residue, metal particles left over from the grinding process, or glue residue from previous wirings. Shape the end of the stick with a knife to fit the size of the (foil or epee) blade groove and continue scouring until the stick comes away clean. This will take several minutes and several sticks.

Where a previously-wired blade will not come clean in the soaking process, (often this will be the case when epoxy cement was used) it may be necessary to scrape it clean and then re-soak. If a grinder is available, re-shape an old file, knife, or hacksaw blade into a suitable implement. If not, a broken hacksaw blade may do the trick without reshaping. After the blade has been scraped relatively clean, re-soak and then re-scour it with the wooden stick. The scouring is important because it will remove any metal slivers that may cause short circuits later on. If glue residue still remains, it may be possible to remove it (especially from epee blades) using emery cloth or a similar abrasive.

2. Trial-fit the barrel on the end of the blade. With new blades, this will often be a tight fit. Once the barrel is started on the threads, tighten it slowly, using the small vise-grips. Grip only the base of the barrel, since pressure exerted further up may crack or flatten it. If the threads are extremely tight, one or two drops of light oil may be applied, although this must be removed afterward (using acetone).

When a satisfactory fit is obtained (the barrel should have gone 4 or 5 complete revolutions), remove the barrel again and inspect the threads. Use a wire brush or small warding (key) file to remove any metal burrs, especially from the groove. If the blade is a foil blade, check that the groove has not collapsed so that the wire will not pass through, and if it has, use the file to widen it slightly. Do not remove any more metal than absolutely necessary, as this will weaken the blade.

The threads that connect the barrel and the blade are cut on a slight taper, so that they become tighter as the barrel is screwed onto the blade. If the point requires more than four or five revolutions before it becomes tight, it may be that the end of the blade is protruding too far into the bottom of the cartridge. With the barrel screwed on tight, test the depth by comparing it with another working point, using a small screwdriver or similar instrument. If too much of the blade protrudes into the cartridge base, it may be necessary to file or grind it down. This is particularly true of epee points, where the blade end may touch one or both of the contacts where they protrude at the base of the insulating plug and cause a short circuit.

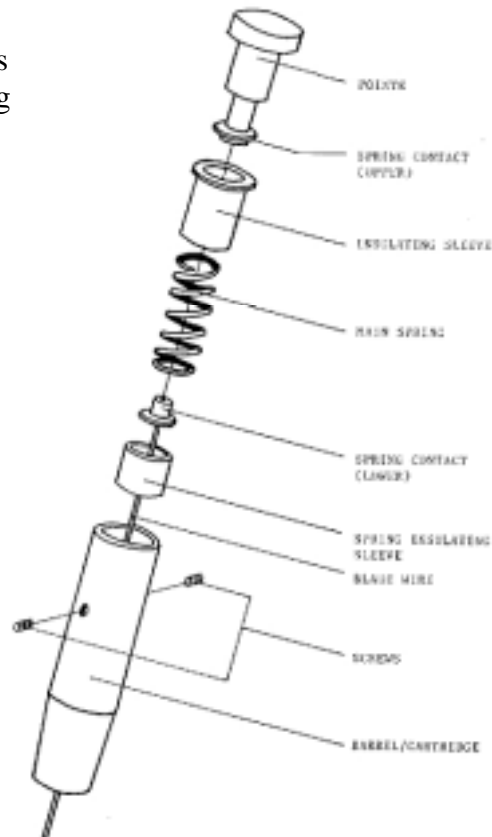

FIG. 1A FOIL POINT
(LEON PAUL)

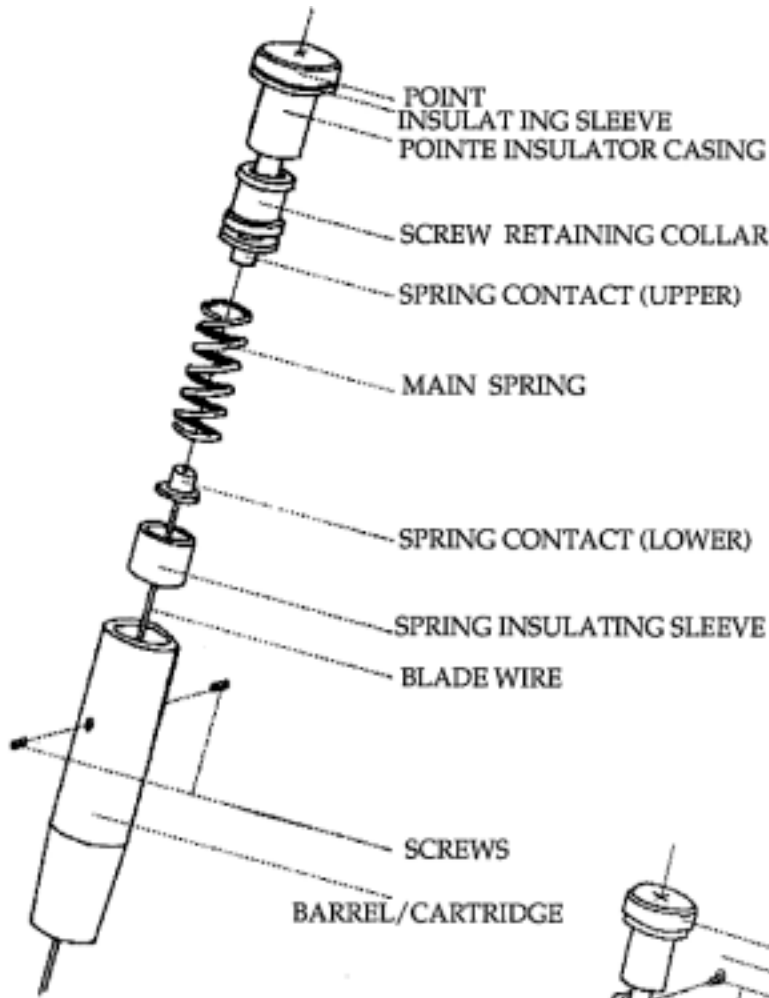

FIG 1B FOIL POINT
(UHLMAN)

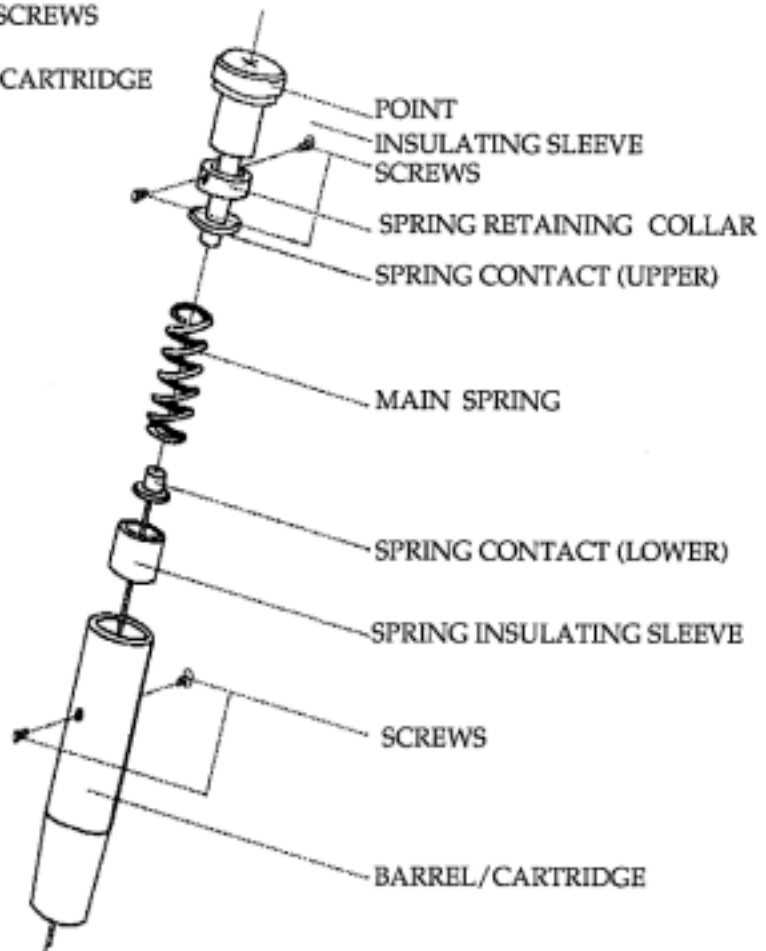

FIG. 1C FOIL POINT
(ALLSTAR/PRIEUR)

3. Unroll the blade wire, carefully removing any kinks or bends, and straighten it • by drawing between the thumb and forefinger.
4. Insert the end of the wire through the barrel, so that about 10 cm of wire emerges from the base (threaded end).
5. Fit the barrel back onto the blade (clean off oil first, if any was used), and tighten firmly with the vise-grips. Too much pressure here will split foil cartridges, and too little will result in a loose point later on, causing electrical problems. Experience is the only way to determine just how much pressure to apply. Use more pressure when setting epee barrels, as these are less likely to split, and are subjected to much greater stresses during fencing.
6. Draw the wire smoothly through the groove until the insulator comes in contact with the end of the barrel. Avoid scraping any insulation off the blade wire(s). If an epee blade is being wired, it is necessary to determine whether there is a spacer ring in place (see Fig. 2). If there is, the ring on the new wire must be cut off before insertion.

The presence of a spacer ring is determined inserting a small screwdriver or wire into the cartridge until it touches the shoulder or which the wire contact will rest. Mark the point opposite the end of the barrel on the wire or screwdriver, and measure the distance to the shoulder. If it is about 15 mm, the barrel still contains a ring. If it is about 17 mm, a new one is required. If many blades are to be wired, it is a good idea to make a gauge for measuring this by taking a small piece of wire (coathanger is ideal) about 60 mm long. File one end square, and then file a notch flush with the end of a barrel when the wire is inserted right to the shoulder (without a spacer ring). With subsequent barrels, the notch will be flush if a ring is required, and 2 mm outside the barrel if one is already inside.

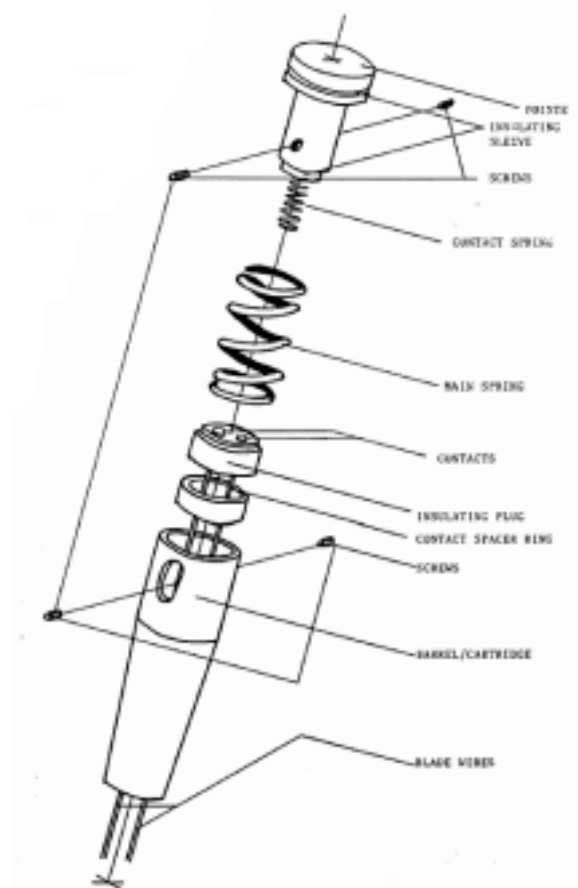

FIG. 2 EPEE POINT

7. Push the insulating plug into the barrel using the setting-rod, ensuring that an equal amount of wire emerges at the blade end as it goes in. If the wire jams during this process, it will probably have to be destroyed, since the barrel will have to be removed to take it out again. Before replacing the barrel (with the new wire), check the groove to see that it has not collapsed. If it has, it must be enlarged with a small file.

In some cases the insulating plug may be a tight fit. If so, the end of the setting rod may be driven in by tapping (gently) with a small hammer. Be careful not to over-drive foil insulators, as they will split. If an epee blade is being wired, tap the rod one last time to ensure that the insulator is firmly seated against the spacer ring and shoulder. If this is not done, the point may be impossible to adjust for travel later on.

8. Strip the end of the wire(s) and connect to the tester. When wiring a foil blade, connect the wire to one side, and the blade itself (or the vise holding it) to the other. When wiring an epee blade, connect one lead to the blade, then test the other against each blade wire in turn. All wires should still be insulated from the blade at this point, so there should be no electrical flow between them. If there is, there is a short circuit from the affected wire to the blade, probably somewhere inside the cartridge. The wire must be removed, and the point reassembled with a new one. In such cases, check the inner surface of the blade groove where it is threaded for rough spots or burrs which could penetrate the insulation on the blade wire(s), and if necessary smooth it with a file or wire brush.

To verify that neither wire has been broken, connect the tester to both (epee) wires and touch the small screwdriver to the ends of both contact points (inside the barrel) at the same time. The same test can be applied to a foil wire by touching the screwdriver to the single contact and the outside of the barrel. Current flow in either case indicates that the wire(s) are intact.

9. When the testing is complete, insert a spring into the barrel, and seat it against the insulator, using the setting rod if necessary. Then insert a point into the barrel, aligned so that the set-screw holes are aligned with the holes in the barrel. If wiring a foil point, it is necessary to insert one screw to hold it in place while further testing is carried out.

If wiring a foil point, insert the screw, and check the tester. The screw completes the circuit between point and blade, so the tester should come on. If it does, place the 500g weight on the point and check the spring tension. It is a good idea to depress the point 10 or 15 times at this point to verify that it is operating smoothly and consistently. Once the point is operating properly, insert the second screw. With foil points using tapered screws (Allstar or Prieur) it may be necessary to loosen the first screw slightly (about one-half turn) prior to starting the second. If so, loosen the first screw, start and drive the second one all the way, then tighten the first one.

FIG. 3 TESTING THE EPEE POINT FOR 0.5-1.5 mm TRAVEL

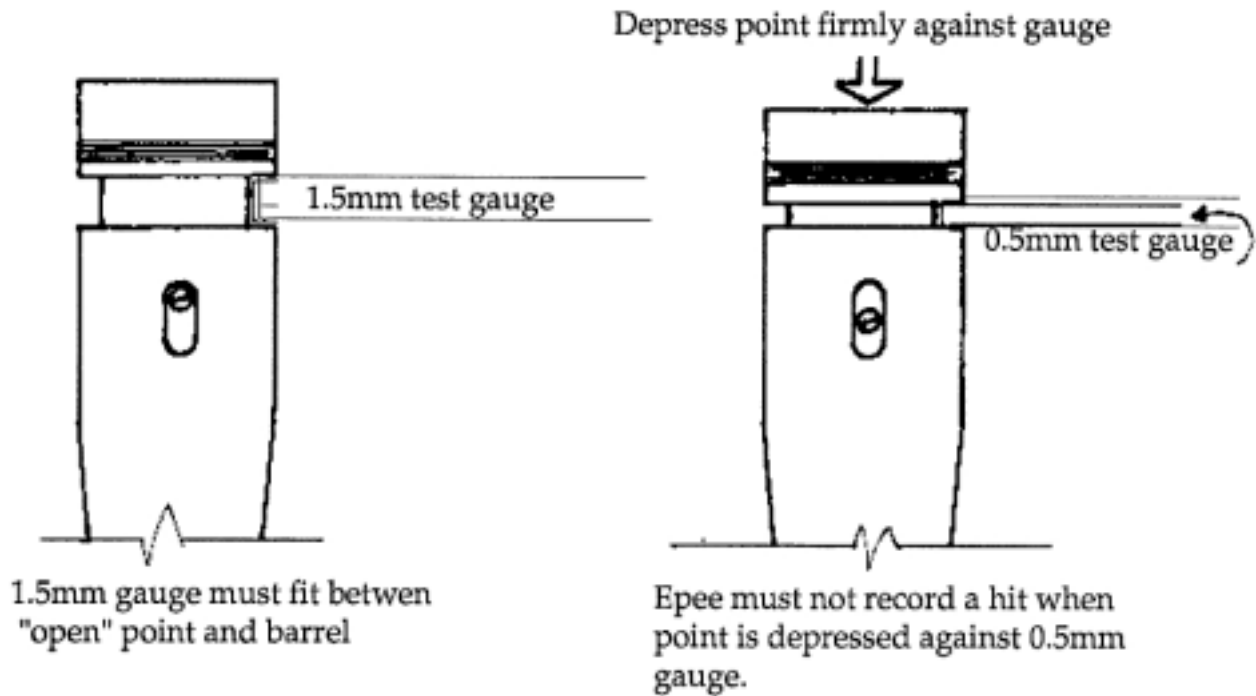

If wiring an epee point, it is not necessary to insert any screws at this stage. Simply insert the point onto the spring, and depress until the tester comes on (when the contact spring touches both contacts). Allow the point to lift slightly, and insert a 0.5 mm test gauge and depress again (Fig. 3). If the tester comes on, the travel must be adjusted by either tightening the contact spring (rotate it clockwise) or flattening slightly against any flat surface. Do not cut the spring.

Ultimately, the contact spring must be adjusted so that it does not close the circuit with the gauge in place, but does close it when the gauge is removed. Until some skill is developed in the adjustment process, care must be used. Bear in mind that the adjustments usually involve very small distances.

10. Once the (epee) travel has been satisfactorily adjusted, insert one screw and place the 750g weight on the point. The spring must lift the weight after the point has been depressed. If this is not the case, remove the screw, and stretch the spring slightly, then re-test.
11. Conduct any final tests to ensure that the point(s) are operating smoothly and that no electrical malfunctions are present. Foil points should open the circuit (tester light goes off) each and every time they are depressed. Epee points should close the circuit (tester light comes on) each and every time they are depressed. If not, the suspect point should be disassembled until the problem is located. The major difficulty with re-wiring blades is the removal of old glue, so it will save work if problems are rectified before any glue is applied to the blade.

12. Once the point working properly, the gluing may begin.

If you are not already wearing eye protection, put it on now. Bend the blade firmly and place both ends securely in the wiring jig. Secure it in a vise in such a way that the groove is up and the blade can be worked on safely (Fig. 4). Mix the glue, if this is required (epoxy).

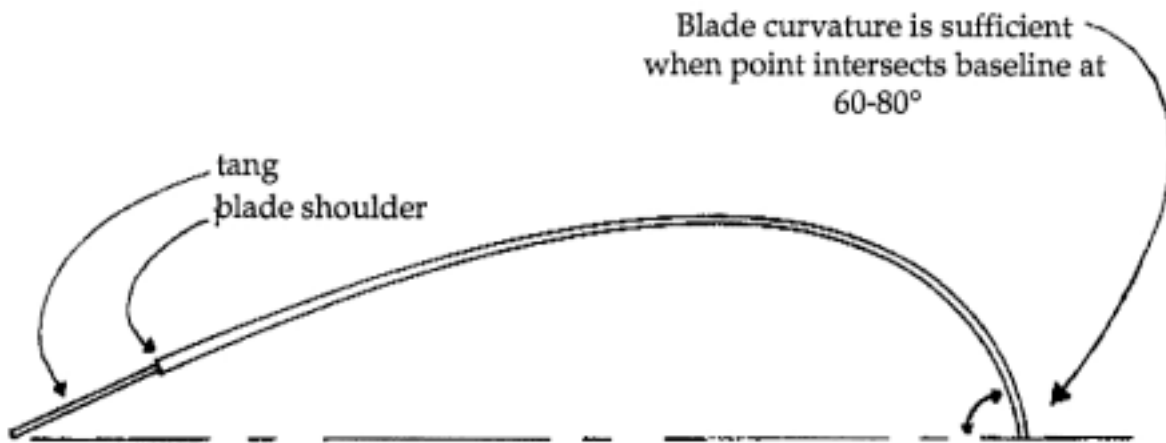

FIG. 4 CORRECT CURVATURE FOR GLUING OF BLADE WIRES

13. Take the blade wire in the left hand, and stretching it slightly, apply glue with 13 the right hand, working it in with the thumb and index finger. Care must be taken not to apply glue to the part of the wire that will be behind the shoulder once the wire is in place. Note that this step should be omitted if working with cyanoacrylate glues, as these will bond to human skin.
14. Draw the wire back so that it lays in the blade groove back to the shoulder. Enough tension should be maintained to keep the wire straight, but care must be taken not to pull the point out of the wiring jig. Secure the wire at the shoulder end of the blade, maintaining tension constantly. If wiring an epee blade, repeat the same procedure with the second wire.
15. If cyanoacrylate glue is to be used, contact with the skin must be avoided. Therefore, it is necessary to lay the wire in the groove first (maintain tension) and secure it in place. The glue may then be applied over top using the applicator provided.

Cyanoacrylate glues are produced with a very low viscosity, which causes them to flow into very fine cracks and spaces. This means that they will completely penetrate the cloth insulation on the blade wire, and any spaces between it and the inner surface of the groove, provided that the spaces involved are small. It will also travel for as much as several inches along the cloth insulation and penetrate into the base of the point mechanism if this is assembled. The effect of this is to glue the entire assembly into a useless mass. In order to avoid this problem, disassemble the point prior to wiring with cyanoacrylate glues, and use only small quantities on the wire close to the point. A single drop on the wire about 4 cm back from the base of the barrel is usually sufficient. If possible, orient the blade so that the glue must run uphill into the barrel area.

16. If epoxy or a similar glue was used, it should be cleaned off the fingers before it has time to set. Fast ("5-minute") epoxy will set in five to ten minutes at room temperature, and the set time decreases rapidly as temperatures increase. At 30 degrees (Celsius) there is just enough time to properly wire a complete epee blade, if one works efficiently.

When wiring epee blades, it is necessary to check for any unnecessary accumulations of glue in the groove near the shoulder. Any surface of the epee which is insulated from the scoring apparatus will register a valid hit if struck by the opponent's point. The last 15 cm of the groove in the epee blade near the shoulder end is wide enough to permit the point to do this by striking the glue without coming into contact with the blade itself, if such accumulations are permitted.

FIG. 5 SAMPLE DESIGN FOR BLADE-WIRING JIG

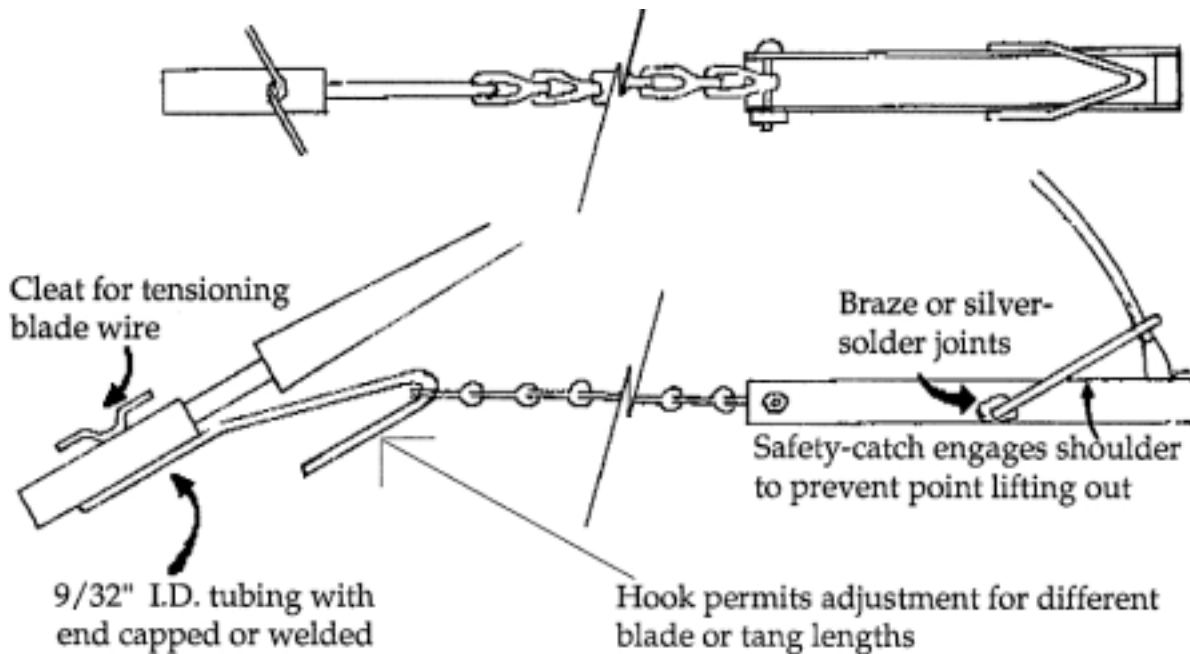

17. Once the glue is applied, the blade may be disconnected from the tester, removed from the vise (still held in the bent position by the wiring jig), and set aside to allow the glue to dry/cure fully. With fast epoxies, it is recommended that blades be kept in the bent position for 24 hours, if possible (they may, however, be used immediately if necessary). Epoxy glues do not cure properly in a cold environment, so blades should be stored at room temperature if possible.

Care should be taken to store bent blades in a safe place and out of the reach of children. While the blade is bent in the jig, it is potentially quite dangerous, and should be treated accordingly.

18. Once the glue has cured satisfactorily, the blade may be allowed to straighten (carefully!), and is ready for assembly into a completed foil or epee.

1.2.2 WEAPON ASSEMBLY

Actually assembling the component parts of a foil, epee, or sabre is not difficult, and most problems result from oversights rather than a lack of skill or know-how. It is therefore important to develop a system for assembly, and to follow it consistently, especially during competitions and other high-pressure situations where errors are most likely to occur. A clean, well-lit work bench with a good vise is essential. If several weapons are to be worked on simultaneously, several small dishes or trays should be kept handy to store the small parts (one dish for each weapon) to avoid loss. Weapons should always be worked on in the same orientation (e.g.: with the blade groove towards or away from the assembler) so that the various parts fitted on to the tang of the blade during assembly will all be in the same orientation on every weapon, which lessens confusion.

1.2.2.1 Materials required

- pre-wired foil or epee blade, or sabre blade
- foil, epee, or sabre guard
- female electrical connector (foil, epee)
- pad or cushion
- grip (french, pistol, or sabre)
- pommel or ortho-nut (inside or outside hex, or slot)
- insulating tape (cloth bookbinders' tape) (foil only)
- 1 mm (inside diameter) insulating tubing
- machine or cutting oil (for threading)

1.2.2.2. Tools required

- safety glasses or other eye protection
- 2 mm screwdriver for point screws
- 3-4 mm screwdriver for electrical connections
- soldering-iron and solder
- large (10") vise-grips for tightening pommels
- foil (500 g) and epee (750 g) test weights
- 0.5 mm and 1.5 mm epee test gauges
- electrical tester with leads (for bodywires)
- utility knife or scraper. (disposable blade type)
- 4 mm (dia.) chain-saw file
- 10" mill or bastard file
- 10 12" hacksaw
- 6 × 1 mm threading die and holder
- 6 mm hex key/wrench (for ortho nuts)
- wire cutter-strippers
- small needle-nose pliers or tweezers
- steel pipe 7-10 mm I.D., 25 cm long (for bending tangs)

1.2.2.3 Safety notes

The only major hazard involved with weapon assembly is that of eye injury caused by tool slippage or flying debris from sawing, filing or grinding. Safety glasses should be worn at all times, and if a power grinder is used, fully-enclosed goggles or a face visor must be worn.

Minor injuries to the hands from sharp tools (or a hot soldering-iron) are fairly common. These cannot be avoided completely, but a clean, well-organised work area and good work habits will reduce them to a minimum.

1.2.2.4 Procedure (Foil and Epee)

1. Lay out all parts to be assembled and inspect for defects. If an existing weapon is being dismantled, parts should be placed in a tray or dish to keep them separate.
2. Place the foil or epee blade in the vise, with the wire side closest, and point down. Inspect the shoulder area of the blade for squareness and evenness. If the shoulders are rounded or do not match, file them until they do. Otherwise the bell guard will not be square and the weapon will have a tendency to work loose during fencing.

The length of the blade, measured from the shoulder to the point, should also be checked. Note that this dimension, when measured on an assembled weapon, must not include any washer or similar spacer on the front of the bell guard². This means that, where such a spacer is present, the equivalent thickness may have to be removed from the blade shoulder on each side. Foil blades designed with the wire groove on the bottom, or inside curve should be reversed in the vise so that the alignment of the rest of the parts is the same.

3. The blade should now be "set" for a left or right-handed fencer. Place the steel pipe over the tang and bend it from the shoulder until it is about 5 degrees out of line with the rest of the blade. In the vise, this bend is away and to the right for a right-handed fencer or to the left for a left-hander (Fig. 6). If the weapon is held in the fencing position, the bend should be down and to the left for a right-hander, down and to the right for a left-hander. Care should be taken to make the bend in the steel just below the end of the blade proper (shoulder), as bending further down will make fitting the grip difficult. The precise angle of bending will vary from one fencer to another, and can be determined either by asking the fencer what is comfortable, or by observing his or her actions in competition. Under pressure, the fencer will carry the blade in the most natural position, and it is for this position that the weapon should be adjusted.

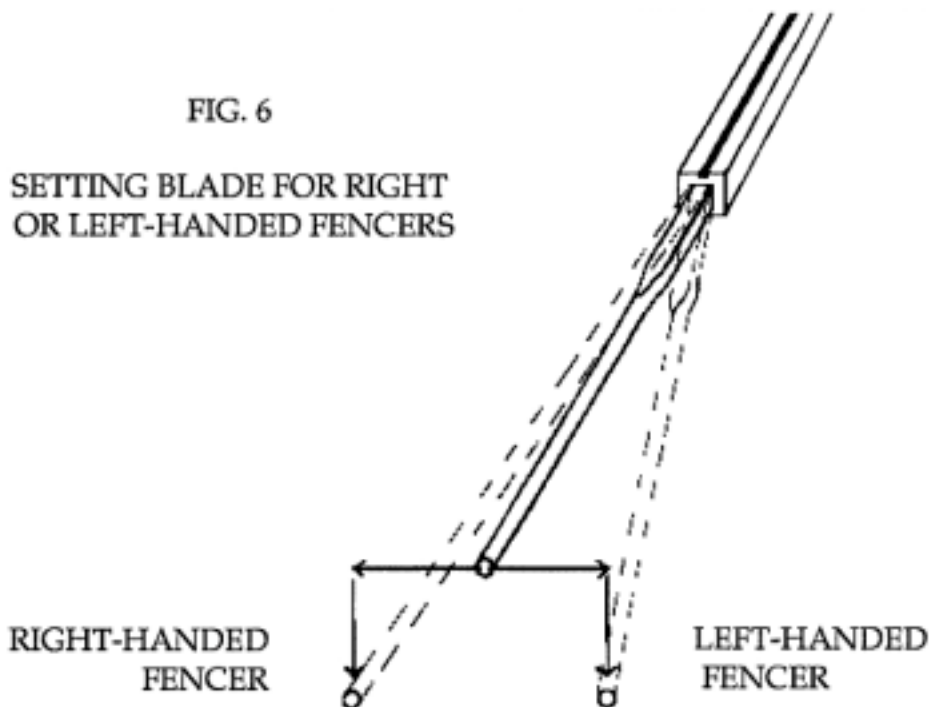

BEND TANG ABOUT 5 DEGREES OUT AND DOWN FROM SHOULDER

2. See: Regulations for Competitions, Articles 24, 206 (foil) and 307 (epee).

The steel pipe should be about 40 cm long with an inside diameter of about 8 mm (the smallest size that will slide over a blade tang is best), and should have a fairly thick wall, since it is used as a lever for bending blades. If such a pipe is not available, blades may be bent by clamping the tang in the vise about 1 cm from the shoulder, and using the blade itself to make the bend. Blades will occasionally break using this procedure, however.

4. The tang must now be cut to the proper length for the grip that will be installed. If the weapon has been used before, this may be done simply by measuring the length of the old blade and cutting the new one the same (check that the old one was the right length when disassembling the weapon). If not, slide the new grip onto the tang until it is about 7 mm from the shoulder (to allow for the thickness of the bell, connector, and padding), and mark the cut. French grips will usually not require any cutting. The threaded part of the tang should extend about 10 mm beyond the end of the pistol grip counter-bore (where the ortho nut will fit). New pistol grips must be fitted to the individual fencer before this measurement is taken (see #11, and Fig. 7).

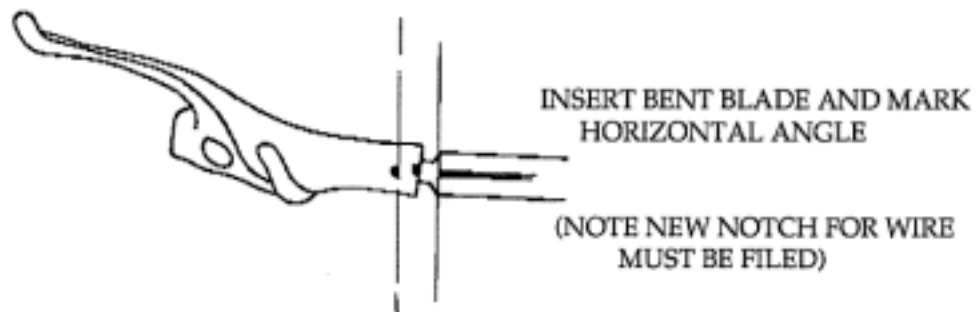
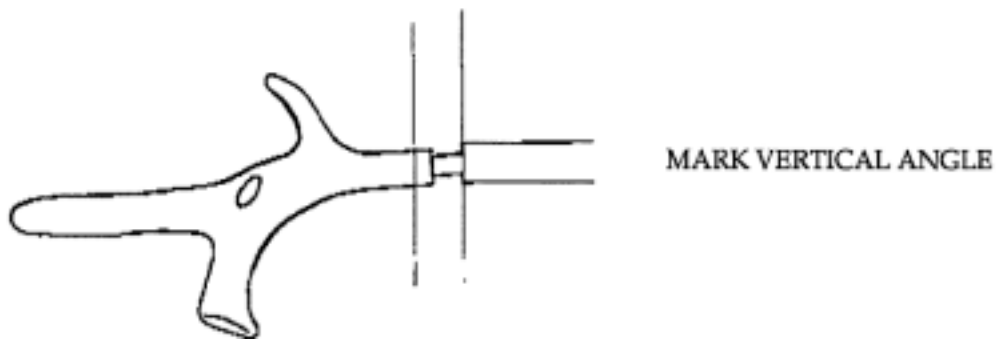

FIG. 7 FITTING PISTOL-GRIPS



The tang may now be cut, using the hacksaw. It will be easier to cut if placed in the vise in such a way that it cannot vibrate. If the vise jaws are clamped just on the off-cut (waste) side of the cut point, threads will not be damaged. Once the tang is cut, re-fit the grip that will be used, and check that there are sufficient threads to permit the ortho nut or pommel to be tightened after assembly. If additional threads must be cut, do so now (using the threading die), as this avoids accumulations of metal bits inside the bell that can cause malfunctions later on.

It is a good idea to use a few drops of light machine oil or cutting lubricant while cutting threads. Try to prevent any oil from coming into contact with the blade wires (this may interfere with the glue), and clean off any excess after cutting and threading is complete.

5. Inspect the bell guard and trial-fit it onto the tang. If the guard does not have a • groove filed into the square centre hole for the blade wire to pass through, cut one (using the chain-saw file).
6. Cut a piece of insulating tubing about 10 cm long, and slide it onto the blade wire, • pushing it up to the point where the wire emerges from the blade groove. Then cut the wire about 2 cm longer than the insulation and bend it over the end of the insulation to prevent the insulation from slipping.
7. Slide the bell guard onto the tang, threading the insulated wire through the hole as it goes on. If an epee is being assembled, the bell must be correctly oriented, since the "centre" hole is in fact about 30 mm off-centre³. The bell is oriented so that the extra protection covers the bottom side of the grip and the back side of the fencer's hand. For a right-handed fencer this means that the bell protrudes to the right side and away from the assembler (assuming the blade is correctly oriented in the vise), and for a left-handed fencer it protrudes to the left and away (see Fig. 10B, page 31). Orientation can be easily verified while the blade is still in the vise by simply gripping the tang, thumb on the wiring-groove, with the right or left hand, as appropriate.

If the bell has previously been used for a different fencer, it is necessary to check that the wire groove is on the correct side for left or right-handed assembly, and if not, to cut a new one. Do not assume that the bell goes on with the existing groove lined up with the wire, because the weapon will be backwards if the current user fences with a different hand than the previous user. If the blade has previously been used, the set of the tang should also be checked and re-bent or adjusted, if necessary.

8. When the bell is fitted with the insulated wire emerging from the groove, slide the female connector (3-pin for epee, and 2-pin or bayonet for foil) onto the tang, threading the wire through the hole as it goes on. The wire must pass through this hole. If it passes between the bottom of the connector mount and the inside of the bell it will be cut by the pressure of the ortho nut or pommel on the back of the grip. (see Fig. 8, page 20).

The connector is oriented so that it will be on the left side of the weapon for a right handed fencer, and on the right for a left-hander. In the vise this is reversed, with the connector on the right for a right-hander, and vice-versa.

3. This is known as eccentric mounting, and is used to afford better protection to the fencer's hand and forearm. The amount of eccentricity (i.e.: the maximum distance between the real centre of the guard and the actual hole) is limited to 35 mm or less, and is generally less, since too much eccentricity exposes targets on the other side. See [Regulations for Competitions](#), Article 310

FIG. 8 COMPLETE WEAPON

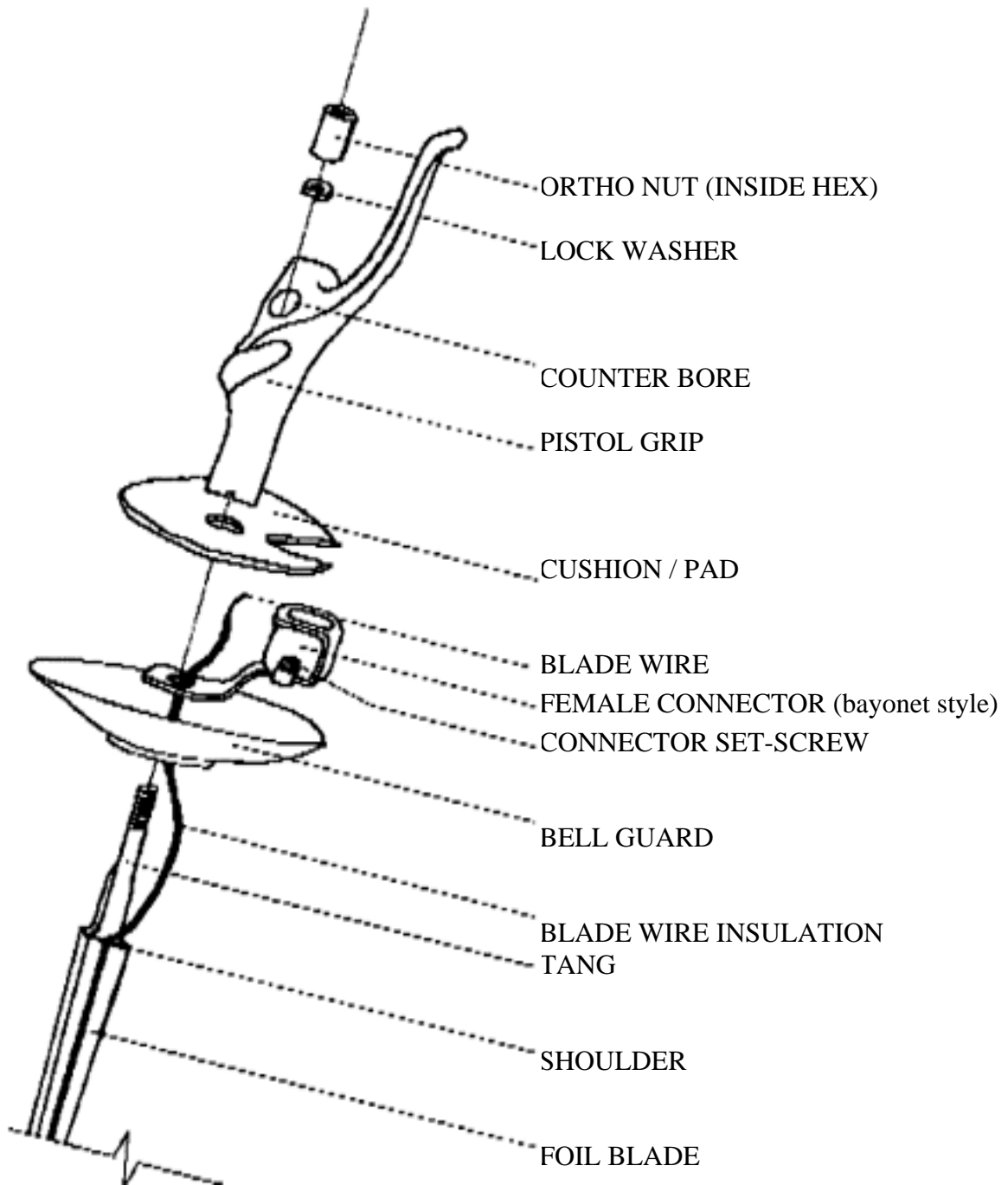

9. When the connector is in place, lay the wire out across the inside of the bell, and anchor it in place with a small piece of tape. It must be fixed in a position that will avoid damage when the grip is placed over it and bolted on. The tape should be relatively small, since it may have to be removed from time to time for inspection during weapon control at competitions.

10. The pad may now be slid onto the tang. If it has a notch for the electrical ¹⁰ connector, it should be oriented so the two line up. If not, it may be advisable to cut one.
11. If a new pistol-grip is to be installed, it must first be fitted to the fencer who will use it. As a general rule, a weapon balances better if the fencer's hand is as close to the balance point as possible. Since this point is always in front of the bell (usually 5-10 cm depending on grip configuration), the pistol-grip should be cut so that it is as short as possible without cramping the thumb or index finger inside the bell. Have the fencer hold the grip with the thumb laying flat along the top side, and mark the shaft with a file about 5 mm beyond the end of the thumb.

The grip will be cut off at this point, but the cut should not be square to the shaft of the grip. The cut must be angled down and to one side to allow for the angle bent into the blade tang. If the grip end is square, it will straighten out the tang as the ortho nut is tightened.

To determine the angle that must be cut, slide the grip onto the tang, and sketch the angle at the marked point, using the blade shoulder for reference (see Fig. 7, page 18).

Now cut the grip to size with the hacksaw, remove any burrs or imperfections with the file, and cut a new wire groove with the chain saw file. Pistol grips are usually die-cast from aluminum, which has a tendency to clog ordinary files. If many grips are to be cut, it is a good idea to obtain a coarse file (10" bastard) for this purpose. The same file can also be useful for customising grips by removing metal from other parts.

12. Check that there is a groove cut into the base of the pistol grip for the blade wire (do not assume that one exists, even in a used grip). Hold the grip as if it were part of a weapon, and check the base on the side gripped by the thumb. There should be a semi-circular notch 3-4 mm in diameter. If there is none, cut one, using the chain saw file.

Note that some foil blades of Soviet or Eastern-European manufacture are designed to be wired with the groove on the bottom surface of the blade. This requires that the grooves in the bell and pistol or french grip must be re-cut into the bottom surface as well. Bell guards, of course, may simply be rotated until the groove is in the correct orientation. The remainder of the assembly procedure remains the same, except that the blade wire emerges at the bottom of the grip and must be run to the bodywire connector from there.

13. Once the grip is fitted satisfactorily, check that the tang has been cut to the proper length, thread on a 6 mm lock-washer, and screw on the pommel or ortho-nut. As tension is applied, it is a good idea to verify that the blade wire is properly positioned under the groove in the grip by lifting up the pad. If not, it must be re-positioned and fixed in place, or it will be cut when tension is applied.

Apply sufficient tension to prevent any movement (rotation) between the blade and grip. As tension is applied check that the grip is properly aligned with the blade. The thumb surface of the grip should be parallel to the top surface of the blade. If the assembled weapon "feels" wrong, this is a possible cause. The bend of the blade should align with the thumb position (i.e.: it bends straight up if the thumb is on top), and this can be checked by extending the point against a wall. The degree of set bent into the tang, both vertical and horizontal, can also have an effect on this (see also #15).

14. When the grip is installed, fish the ends of the wires out from underneath the padding, and connect them to the terminal(s) on the female bell connector. A slot screwdriver or "nut driver" that matches the fittings on the terminals to be connected is useful for this. If many weapons are to be assembled and reassembled, it may be wise to use a solder connection system. This is much faster, easier, and more reliable, but it requires the coach or fencer to take a soldering iron and solder to competitions for emergency repairs.

The epee bell connector has 3 terminals: centre, 15 mm from centre, and 20 mm from centre. This is to keep the bodywire from being plugged in backwards. The 2 wires from the blade must be connected to the centre and 15 mm terminals. It does not matter which wire goes to which terminal. The third terminal is connected to the bell guard (by the connector mount), to prevent hits that land on the bell from being recorded by the apparatus (Fig. 9).

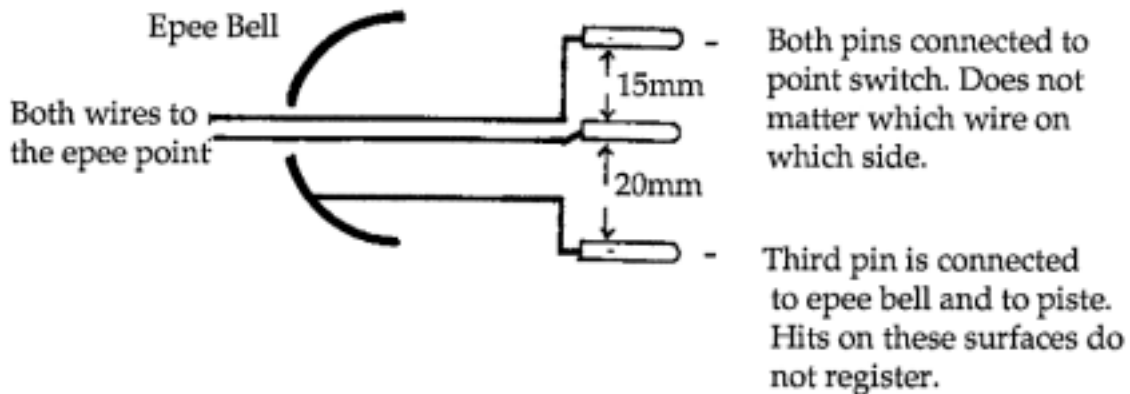

FIG. 9 EPEE SCORING AND GROUND CIRCUITS



Fig. 10 EPEE HIT REGISTRATION (SCHEMATIC)

The foil connector only has 1 terminal, and the single blade wire is connected to this. In the case of 2-pin connectors, the terminal should be on the small diameter (3 mm) plug, with the large (4 mm) plug connected to the bell by the connector mount (Fig. 11, page 33).

Care should be taken to trim wires before and after connecting them so that the insulation extends all the way to the end of the wire, and that no extra wire extends from the connector after the screw is tightened or the wire soldered into place⁴. About 1 cm of bare wire should be allowed to wrap around the terminal. Tighten the screw, and then trim off all excess. In both foil and epee, a bare wire touching the inside of the bell will deprive the fencer of any valid hits scored, and in epee, any connection between the two wires will result in false hits being recorded. In epees, where the connection points may be quite close to the inside of the bell rim, it may also be wise to apply a small piece of tape to the inside of the bell as extra insulation/protection.

15. The final step in weapon assembly is to run a final check on all workmanship to verify that the finished weapon is ready for competition. While no two fencers have exactly the same taste insofar as blade set, grips, etcetera are concerned, the "feel" of it will tell a great deal. Depress the point against the floor or a handy wall as if hitting an opponent. The blade should bend smoothly "upward", with "up" being determined by the orientation of the thumb on the grip (if not, see #13, above). If set correctly, the point should comfortably rest in the centre of an opponent's target area, just below shoulder height, when the en garde position is assumed.

A final electrical check should also be carried out, using the appropriate control weights and gauges. For both foils and epees, it is also a good idea to make a number of hits against the point with the hand. Check for smooth movement of the point inside the barrel, and ensure that the weapon registers every hit on a test-box. If not, there may be an intermittent fault of some sort (see Maintenance, below).

16. If the completed blade is for a foil, it must also be insulated for the first 15 cm., measured from the tip of the point. This will prevent the metallic surface of the blade from coming into contact with the opponent's metallic plastron when a hit is scored. While any metallic part of either weapon is in contact with this plastron, a touch which arrives on it will not be recorded by the apparatus. It is particularly important to ensure that the last millimetre or so closest to the point is covered, as this is most likely to touch the opponent during a hit.

The tape itself adds significantly to the weight of the point in determining the balance of the foil, so a compromise must be struck by using as little tape as possible, while providing durable and complete insulation. Surgical adhesive or bookbinding tapes are ideal for this purpose. In the case of a fencer who prefers a heavy point (this increases the amount of whip in the blade), some weight can be added in the form of extra tape.

4. Regulations for Competitions, Article 217, paragraphs 5, 6 (foil), Article 314, paragraphs 5, 6 (epee), and Article 712, paragraphs 3 and 4.

1.2.3 WEAPON MAINTENANCE AND REPAIR

1.2.3.1 Foil maintenance

If the blade of the weapon has been wired properly, it should be relatively trouble-free for as long as the blade itself lasts. The components of the point (especially foil points) are subjected to enormous stresses in competition, however, and may need repair or replacement from time to time. The tension in the point springs will also have to be adjusted several times per year, depending on use. Most other problems result from either inadequate assembly procedures or exceptional wear and tear in fencing.

Foil points should be tested and re-set to 500g (or more) prior to each competition, and retaped to ensure proper insulation. When testing with the 500g weight, the point spring must clearly lift the weight so as to reset the point after a hit has been registered. It is recommended that a point be reset if it barely passes the test as well, since a marginal point will probably have to be reset during competition. The technical advantages gained by having a 501g point are more than offset by the possibility of equipment warnings and the distraction caused by having to make repairs during competition.

Where a point is too light, or too heavy by a large margin, it should be reset. Maintain pressure on the point and remove both set screws. If the point was too stiff, check the sides of the insulating sleeve for dirt or other foreign materials that may be jamming the point. Often, glue from the insulating tape will creep into the barrel, causing extra friction. Also inspect the outside of the barrel for dents which may have caused it to flatten, even very slightly. Defects or debris which increase friction are a serious problem, since they cause drag in both directions. If a dent creates 75g of extra resistance, for example, the pressure required to generate a hit will actually be increased by 150g. The point spring must be set for at least 575g to pass a control, and a further 75g must be applied to cause the hit to register.

If no contamination or other problems are found, the spring is too "heavy", and should be reduced. While it is possible to do this by heating (which removes the temper from the spring) or cutting short, neither is recommended. Both methods will alter the resiliency of the spring, which will make it necessary to adjust it much more frequently in the future. Cutting may also produce an uneven end. This will cause the spring to exert pressure at an angle to the travel of the point, which may cause drag, jamming, or in extreme cases, a short circuit as the bowed part of the spring comes into contact with the inner surface of the barrel. The preferred method is simply to compress the spring for a few seconds with a pair of pliers prior to installation. It is also possible to maintain a supply of used springs, which can be substituted for competition use. The stiffer springs are then "broken in" in practice sessions.

If (as is more often the case) the spring is too light, it should be stretched slightly with the fingers and replaced in the point. Replace one of the set screws and repeat the weight test. If it passes, the other screw is then replaced as well. Springs are much easier to stretch than compress, so it is advisable to make a number of small adjustments, checking each with the weight, rather than making one large one, and then having to re-compress the spring later.

Once the point is operating satisfactorily, the blade and barrel should be re-taped. The function of the tape is to prevent the lockout of hits when the metal blade surfaces come into contact with the opponent's metallic plastron. Strip off any old tape using an old knife or scraper. Apply a piece of new tape 15 cm long and about 2 cm wide to the blade, starting at the base of the barrel. Begin on the wire side, and wrap the other three sides, finishing with a second layer over the blade wire, and then cut or trim off any excess. It is better to use a minimum of tape and replace it fairly frequently than to apply many layers, as the tape adds a surprising amount of weight to the point. Apply a double thickness of tape to the barrel, ensuring that it extends flush with the front end, and overlaps the blade tape at the base. It is important not to leave a gap at the front, since this is the place most likely to come into contact with the opponent's target. Do not overlap onto the gap between barrel and point, however, since this will cause the point to be jammed by glue.

The Regulations for Competitions⁵ require the blade to be insulated for 15 cm from the tip, but this is seldom strictly enforced, since a lack of insulation cannot result in any advantage to the offending competitor. They also require that the "pommel or ... extremity of the grip" be insulated to prevent grounding of the fencer's own metallic plastron. This will become less of a concern as apparatus containing anti-fraud circuitry comes into more frequent use, but tape should be applied (even over painted grips) to avoid equipment warnings during competition.⁶

1.2.3.2 Foil Repairs (Figs. 11&12)

Outside of major damage, such as broken blades, there are two basic types of defect in electric foils. The foil circuit is always "closed" (i.e.: electrical current flows through) unless a hit is made, at which time it "opens", interrupting the current, and recording a hit on the apparatus. Thus, if any component of the circuit breaks or loses contact with the adjacent parts, the circuit becomes "open", and a steady hit will be recorded (off-target) by the apparatus. If a tester with a light is connected, the light will remain off. If there is any failure of the insulation which separates the two sides of the circuit, then the circuit will remain "closed" at all times (even if the point is depressed), and no hits can be recorded at all. This is called a "short circuit", since the electrical current is taking a shorter path than the proper one. If connected to a tester with a light, such a foil will cause the light to remain on, even if the point is depressed.

5. Regulations for Competitions, Articles 211(b), 721. Under Article 231, the president cannot award any touch not recorded by the apparatus. He can, however, annul a hit scored by the opponent in the same phrase after the fencer's initial hit failed to register under Article 231(a), despite the fact that the fencer who was hit was technically at fault for not properly insulating the blade. The exception which prevents annulment that would favour the offending fencer, Article 231(c), is limited to defective masks and plastrons (Article 722(2)-(4)), and would not extend to defective weapons.
6. See note 4 page 22

If there is an open circuit (steady or intermittent off-target), the most likely sources of the problem are at the bell connector (loose or broken wire), the connection between the barrel and the blade (loose barrel), or inside the barrel itself (wire broken, or spring out of alignment). Visually inspect the first two first. In particular, wiggle the barrel while watching the tester, and check the bell connector set screw. If no problem is found, remove the point and point spring, leaving the foil connected to a tester, and short across the gap between the barrel rim and the bottom spring contact (in the bottom of the barrel). If this does not close the circuit, there is a break in the blade wire. Disassemble the foil, and re-test the wire by connecting the end to the tester with an alligator-clip lead. The other lead is connected to the blade, and the screwdriver is again used to short across the point. If the break is in the part of the wire between the blade shoulder and the bell connector, it may be possible to splice on a new extension and re-assemble the foil. If not, the blade must be re-wired.

If the barrel is loose, it may be possible to tighten it, using a small pair of vise-grips or pliers. As with the original installation, it is important to grip only the base part of the barrel, so as not to crush it. If it is very loose, tightening may break the wire at the base of the barrel or bring it into contact with the metal blade, which will make it necessary to rewire the blade entirely. The only way to find out is to tighten the barrel and re-test to check if the wire has been broken.

If the problem is a short circuit (hits will not register at all), the most probable locations of the fault are at or near the bell connector, or inside the point. Inspect the area around the connector, and in particular check that the wire is properly insulated from the bell and that the end does not extend beyond the connector screw or solder terminal. Remove the pommel and grip and check that the insulating sleeve has not been cut at the centre of the bell. This will occur if the wire is outside of the groove in the base of the grip, or if there is no such groove, or if the wire has been threaded between the connector mount and the inside of the bell instead of through the hole in the mount (Fig. 8).

If disassembling the foil does not solve the problem, connect the blade and wire to the tester, clamp the blade in a vise, and remove the point. Short circuits are sometimes caused when the spring is out of alignment and touches the inside of the barrel, or when metallic debris gets inside the point, and touches the spring and the barrel at the same time. Often the uneven end of a cut spring will cause it to bow out to one side, causing it to touch the inside of the barrel. Clean out the barrel, and check the spring for straightness. If the problem was caused by metal debris, check the spring. Some springs are chrome plated, and the plating may flake off during use. If this is the case, either remove any loose chrome, or replace the spring entirely.

There is also a manufacturing defect with the Prieur/Allstar-type foil points made prior to 1985, which can cause intermittent short circuits. This generally appears as the point is depressed, especially if this is done at an oblique angle. With the blade connected to the tester, slowly depress the point. The circuit should open at the beginning of the point's travel. If it opens late or not at all, remove the point, and examine the centre shaft just above the upper spring contact (inside the brass collar that holds the set screws). If the screws are too long, and the point is not perfectly aligned, there may be a brief short circuit between the screw ends and the shaft, which will prevent hits from registering.

Points manufactured after the problem was discovered have a tiny plastic sleeve around the centre shaft, which prevents any short circuiting. Installing such a point will rectify this problem, although it may be solved in some cases by shortening the screws (rub the point ends across an oilstone or fine emery cloth) so the ends do not touch the shaft.

If the circuit remains closed even after the point is removed completely (tester light stays on), then there is a short between the wire and the blade itself, and the blade must be rewired completely. Often this problem is caused by tightening a loose barrel, or scraping insulation off the wire during the wiring process itself. Occasionally short circuits are also caused by improper cleaning of a new blade prior to wiring. Tiny metal fibres and particles are left in the groove during cutting, and these may gradually penetrate the glue and fabric layer around the wire during use.

Occasionally foils may require mechanical repairs, when grips, especially pistol grips, work loose during use. Each fencer or coach should have an appropriate wrench close at hand to tighten grips with as little disruption as possible during fencing. If the grip will not stay tight, or cannot be tightened at all, check the threads on the tang. Often this problem can be rectified by cutting a few additional threads into the tang. If this is not possible, extra lock-washers can be added as spacers underneath the ortho nut. It is a good idea to have a supply of these handy, especially if it may be necessary to exchange grips on a weapon to permit use by more than one fencer, as spacers are generally needed when going from a longer to a shorter grip.

If there are enough threads on the tang, it may be that the tang is too long, causing the end threads to jam inside the ortho nut (this is not a problem with outside hex nuts). If so, the end threads will be damaged. Slide the grip onto the tang, add a lock-washer, and mark the tang for re-cutting about 10-12 mm above the washer. Re-cut and re-assemble.

If the foil can be tightened but will not stay tight, it is possible that the blade tang is too short, and there are not enough threads to support the loads generated when the nut is tightened. If this is the case, there will usually be damage to the last few threads at the end of the tang. Nothing can be done about this except to replace the blade (try exchanging it with someone who uses a shorter grip). If the threads appear to be in good condition, disassemble the foil, and check the shoulders of the blade. If these are rounded, the pressure exerted by the grip tends to enlarge the hole in the bell rather than hold it rigid in position. File them so that they are square and even (otherwise the bell will not be straight), and reassemble.

1.2.3.3 Epee Maintenance (Figs. 9&10, page 22)

Many aspects of epee maintenance are similar to those listed for foils, above, but there are several major differences. The epee circuit works on the opposite principle to that of the foil. The circuit, which runs through the two blade wires, and not the blade itself, is always "open" (no current flow), and closes when the point is depressed, registering the hit.

The epee point (Fig. 2, page 9) travels in and out opposed by a larger spring than that for the foil (mainspring), and carries a smaller spring (contact spring) into contact with the ends of the two blade wires, thereby closing the circuit between the two.

The Regulations for Competitions require that the point must be able to lift a 750 g weight from the depressed position, and that the contact spring not close the circuit until the last 0.5 mm of its travel. In addition, the total travel of the point must be at least 1.5 mm.⁷

Epee points are more prone to slipping out of adjustment than foil points, and should always be tested prior to competitions. Also, many of the possible defects in an epee will be intermittent, and may not give any obvious indications that the weapon is defective. It is therefore wise to test each point 10 or 15 times on a tester, just to check that it registers each and every hit. After this preliminary check, depress the point slowly, feeling for any roughness or resistance which could indicate the presence of debris inside the barrel. The outside of the barrel should also be inspected for dents that could exert pressure on the moving point inside. Test the mainspring with the 750 g weight - remember, the spring must actually lift the weight up from the depressed position so as to cancel a hit already registered. Then test the travel measurements by first inserting the 1.5 mm gauge, then the 0.5 mm gauge (Fig. 3, page 11).

The thicker gauge must fit between the inside of the point and the barrel rim when the point is in the rest position. The thin gauge must prevent the registration of any hit while it is between the point and barrel rim. Insert the gauge, then depress the point, if a hit is recorded, the contact spring is touching too soon and must be adjusted. It is also wise to adjust a marginal point (one that just barely passes this test), since there are often discrepancies between different gauges. In a competition, gauges furnished by the Directoire Technique must govern, and a weapon that passes in the shop may still be excluded if it is tested on the piste with a slightly thinner gauge.⁸

7. See Regulations for Competitions, Articles 18, 311, and 732. Articles 311 and 732 actually require that the point must have a total travel of 1.5 mm or more, that the "lightning stroke", which is the travel from the rest position until the contact spring first closes the circuit, be at least 1.0 mm, and that the residual travel (i.e.: distance from the point of first contact to the end of the travel) not be greater than 0.5 mm.
8. Under Article 18 of the Regulations, gauges may have a tolerance of +/- 0.05 mm (i.e.: 1.45-1.55 mm or 0.45-0.55 mm). Most fencers will not have the equipment to verify that their gauges are within this tolerance (a good micrometer or dial caliper is required), but the local machine shop can be consulted if necessary. It is a good idea to purchase gauges made out of steel, not brass or other softer metals, as these will wear thinner with use.

If the point must be adjusted, remove the two screws while maintaining pressure on the point to prevent it from springing free. Remove the point and mainspring, checking the inside of the barrel for damage or debris. If the point was too stiff, inspect the barrel again for dents that could increase friction.

To shorten or lengthen the travel in the contact spring, grip the end with tweezers or fine needle-nose pliers, and rotate it (clockwise to shorten, counter-clockwise to lengthen) if possible. It may be necessary to stretch or compress the spring to adjust for length, but the rotation method is preferable. Avoid cutting the end of the spring, as this results in an uneven end that will not touch both contacts at the same time. This will delay hits, turning double touches into touches against in many cases. It may also prevent very brief hits from being recorded at all. If the spring was rotated, ensure that it is fitted tightly enough to prevent it from revolving during use, which would alter the travel.

The mainspring should be adjusted by stretching or compressing in the same manner as for foil springs (above). For the same reasons given for foil springs, it is not recommended that these adjustments be made by heating or cutting the spring.

Unlike foil points, an epee point can be re-tested without replacing the screws, which saves time if repeated testing and adjustment is required. Begin by adjusting and testing the travel. Replace the point in the barrel (leave the mainspring out) and test the travel using the 0.5 mm gauge. Then add the mainspring and test for weight. When this is adjusted properly, depress the point with a finger, and insert both screws.

A single, small drop of light machine oil can be added into the gap between the barrel end and point as a final measure. This will decrease friction in operation, and also protect the bearing surfaces of the point from rusting if kept inside a damp fencing bag for any length of time. It will also cause dust and grit to adhere to the point and barrel, however, so if oil is used these should be cleaned periodically with a cotton swab and re-lubricated. Use only a minimum of oil, as it may flow out along the surface of the blade groove, interfering with the bond between the wires and the blade.

As with foils, epee bell guards will record hits if they are covered by any substance that does not conduct electricity well. Unlike foils, however, such hits at epee are recorded as valid. This makes it important to ensure that they are kept clean and free from oxides. Aluminum oxide (which will accumulate on the bell proper) does not interfere with the circuit, but iron oxide (rust) which may accumulate on areas of the blade or centre washer on the bell occasionally does. Avoid storing epees in damp or corrosive atmospheres (such as the insides of airtight fencing bags), and clean when necessary with a wire brush or fine emery cloth.

1.2.3.4 Epee Repairs

Electrically speaking, epees are prone to the same defects as foils, but since the circuits work on opposite principles, an identical problem often results in the opposite effect. Any defect which causes a short circuit between the two blade wires will cause a false hit to register, and any break in the circuit will prevent actual hits from registering. Unlike foil, the epee has a third circuit in the metal part of the weapon itself. This is the same circuit that runs through the metal piste, and any contact between it and the scoring circuit (either side) will prevent hits from registering as well. (Fig. 9&10, page 22).

If hits are not being recorded by the scoring machine, connect the weapon to a tester and perform the following tests. First, test between the centre and 15 mm (closer) pin of the bodywire. If the circuit does not close at all when the point is depressed, there is a break somewhere. Inspect inside the bell guard for broken wires or loose connections. Remove the point, and close the circuit manually by touching both contacts with the end of a small screwdriver. If this does close the circuit, the point is not closing it because the contact spring is too short. Lengthen it slightly (see Maintenance, above), and test again, using the point. Continue lengthening it (gradually) until the circuit closes properly, but not so far that it will close with the 0.5 mm gauge in testing position. This should clear up the problem and the point can be reassembled.

If testing with the screwdriver does not close the circuit, there is a break somewhere else. Disassemble the weapon, and test the wires by connecting directly to the tester and closing the point end with the screwdriver as before. Check for damage to the wires at the point where they pass through the connector mount and under the base of the grip. If it has been cut here, it maybe possible to splice back together. If not, the break is in the blade or point, and the blade must be rewired.

If the scoring circuit is opening and closing properly on the tester, but a scoring machine still will not record hits, there is a short circuit somewhere between one or both of the wires and the blade or bell guard. Scoring apparatus is designed not to record such hits in order to cancel hits on the piste or the opponent's bell guard automatically. Connect one side of the tester to the blade itself (or to the vise it is clamped in), and the other side to each of the two blade wires in turn. One or both will show a short circuit across to the blade. Remove the point and test again with a screwdriver. If this solves the problem, it was caused by metallic debris in the point or a spring out of alignment touching the barrel. If not, disassemble the weapon and check for places where the connector mount or grip base have cut through the insulation, allowing the wire inside to touch the inside of the bell guard. Also check for short circuits in the area of the connector itself. Often the bare end of a wire is not trimmed off at the terminal and extends out far enough to touch the inside of the bell. If this is the problem, trim the wire and add a piece of tape inside the bell to insulate it.

If the problem still persists, the short circuit is inside the blade or the base of the barrel itself, and the blade must be rewired. Such problems often arise when the barrel has been retightened after wiring, or where insulation has been scraped off the wire during the gluing process.

If the weapon is registering hits that are not scored (usually continuously), there is a short somewhere between the two blade wires which make up the scoring circuit. Remove the point, and check the gap between the two contacts for metallic debris. If removal does not open the circuit, disassemble the weapon itself, and check for places where the insulation has been damaged inside the bell, allowing the two wires to cross. This is fairly rare, since such defects usually also bring one or both wires into contact with the bell, locking out all hits.

If the problem persists, the short is somewhere along the blade, or inside the barrel base. The wiring should be removed immediately to ensure that the blade cannot be used in competition, since this defect, if intermittent, favours the competitor with the faulty equipment. When such a fault is discovered by the officials at a competition, the weapon should be confiscated, and the fencer using it could be the subject of disciplinary action, if the defect was known to him or could have been deliberately caused.⁹

EPEE BELL GUARDS (HEAD-ON VIEW)

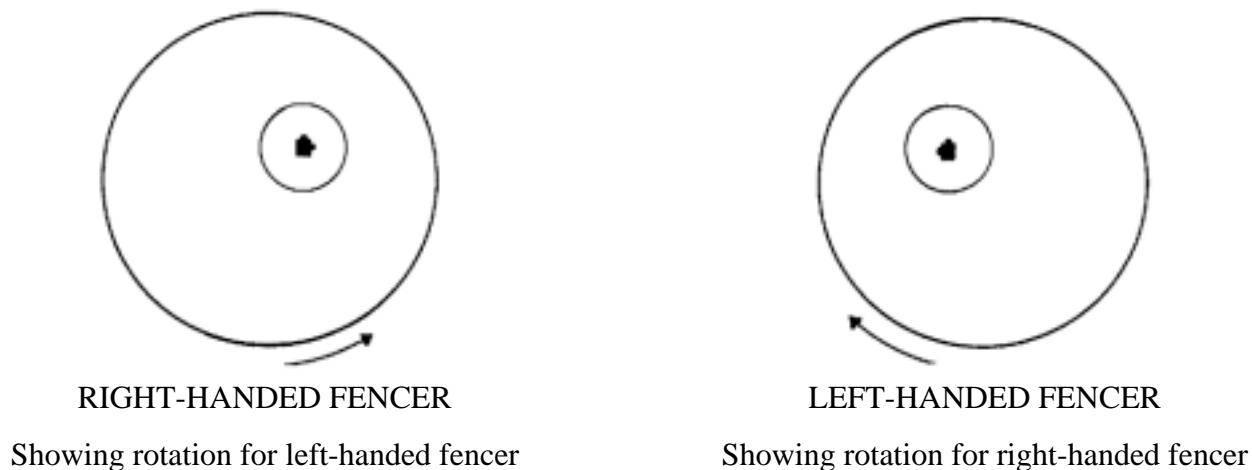

FIG. 10B ECCENTRIC MOUNTING

9. See Regulations for Competitions, Articles 21(3), 326, 327, 639, 648 and 650(4). The penalty provisions in these Articles clearly apply to fencers who alter or may have altered equipment to their own advantage, but may not apply to those who knowingly use defective equipment if the defect was not deliberately caused. Thus, for example, a fencer using an epee that had previously been recording false hits (but was clearly not modified so as to do so) might not fit within the sanctions. It is therefore imperative that officials at competitions immediately remove such a weapon from circulation and render it unusable until the blade is rewired. This can be done by tearing the wires out and/or removing the barrel before returning the parts to the fencer or coach. Since repairing the defect would require complete rewiring of the blade, there is no loss to the fencer (unless, of course, he or she intended to use the epee with the defect, which is cheating).

1.2.3.5 Repair and Maintenance of Bodywires

Epee bodywire

Epee bodywires are relatively uncomplicated, since they have the same connectors on both ends. The regulations require only that the wire have the conventional 3-pin male plug at the reel end, and that the other end be designed so as to avoid electrical problems such as accidental contact with the inside of the bell-guard.¹⁰ The pins of the reel-end connector are spaced at 15 and 20 mm from the centre pin so as to prevent the plug from being connected backwards.

The centre and 15 mm pins are connected to the two blade wires, while the 20 mm pin is connected to the bell guard. As with the epee itself, any short circuit between the centre and 15 mm pins will cause a false valid hit, while any short between either of those pins and the 20 mm pin will cause hits actually scored not to be recorded by the apparatus (Figs. 9 & 10, p.22).

It is important to routinely inspect and maintain epee bodywires because the first indication of any defect will usually be when the fencer fails to score hits in practice or competitions. Also, since epee hits are often cancelled out by the scoring apparatus as out-of-time simultaneous attacks, a bodywire defect may go undetected for some time, with a disastrous effect on competitive results. Both ends of the wire should be disassembled several times each year and checked for loose connections, breaks in the wire itself, and stray strands of wire shorting across to other connections. If bodywires are subjected to fairly heavy use, the wire itself should be replaced every second season, or older wires retired to the practice salle. When purchasing wire, obtain the finest possible stranding, as this reduces metal fatigue in the wire. Fairly heavy (#16-18 AWG) wire is best for the same reason.

Loose connections and broken wires are a serious problem, because they may only open the circuit intermittently. Connect the wire to a tester and short across all three pins at the other end. The pins connected to the tester should show a closed circuit. Wiggle the connectors at both ends, and place the entire wire under tension (usually this can be done a few inches at a time), watching the tester lights. If there is any dimming or flickering, the fault must be located and repaired. Such a defect should also be immediately suspected in competition if valid hits occasionally fail to register (even once), or if hits on the bell guard occasionally register valid.

The connectors themselves should be of fairly robust construction, but the weapon-end must be compact enough and located so that it is not exposed to hits around the bell guard. Either the bodywire plug or bell connector should be equipped with a fastening device that will prevent the plug from being pulled loose while fencing. Note that hits scored against a fencer who was disabled because this plug was disconnected cannot be annulled on this basis.¹¹

10. See Regulations for Competitions, Articles 314, 712, 710 and 717.

11. See Regulations for Competitions, Articles 326 and 327(f). Note that hits can be annulled where the connection between the bodywire and the reel cable are defective, but no such exception is provided for the connection between the wire and the weapon itself. A break at the reel cable connection cannot lead to annulment, however, where a fastening device was present and functional, but not used by the fencer. (See Articles 327(f), 710).

Foil bodywires

Foil bodywires are just as prone to defects, but the most common defects involve a break somewhere, and therefore draw attention to themselves by triggering an off-target registration on the apparatus. The two major concerns with foil bodywires are short circuits in the scoring circuit (which prevents valid or non-valid hits from registering), and breaks in the target circuit (which cause the opponent's valid hits to register non-valid).

Foil bodywires should be visually inspected prior to each competition, and given thorough maintenance once each season. The wires themselves should be replaced every two years if subjected to fairly heavy use. Disassemble the 3-pin plug and inspect for loose or broken connections, and for potential short circuits. Tighten all screws. Disassemble the bayonet or 2-pin connector at the weapon end of the wire and do the same. Inspect the connection at the alligator clip, and check the last six inches of wire at each of the three ends for breaks, cuts or other damage. Check that the alligator clip spring is properly positioned and is providing sufficient pressure to ensure a good grip on the metallic plastron¹².

FIG. 11 FOIL SCORING AND TARGET CIRCUIT

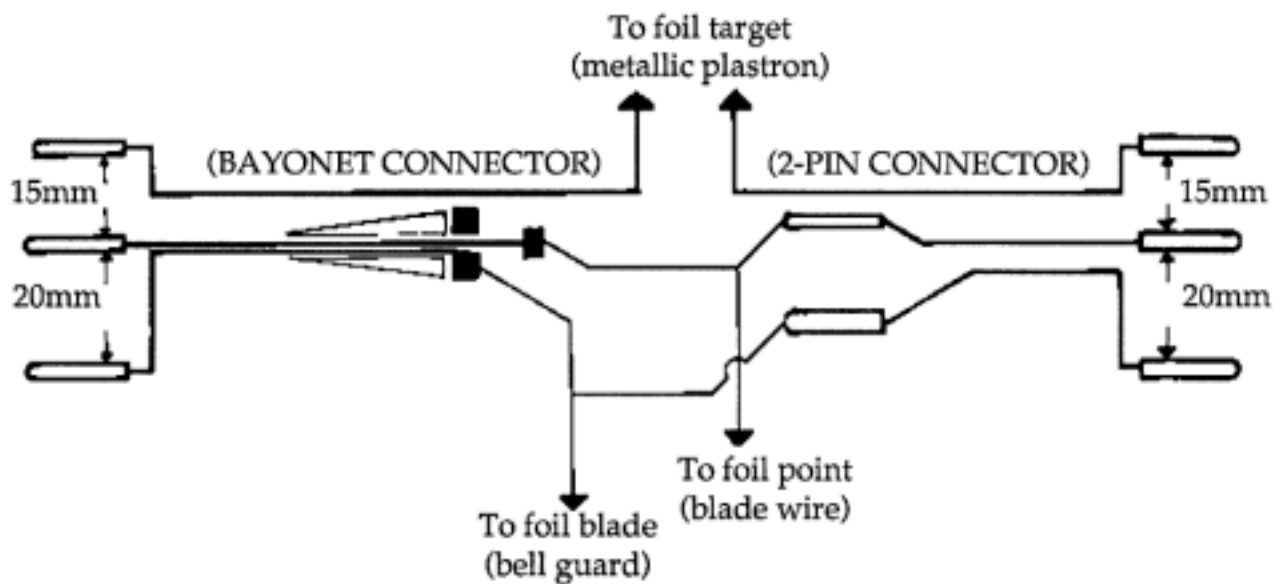

To verify that the bodywire is working, connect the 3-pin end to a tester, and then use the alligator clip to connect the other two wires (2-pin or bayonet end). This effectively shorts all three circuits together. With the tester connected across the centre and 20 mm pins, apply tension at both ends of the wire. If there is a break in either line, the circuit will open, causing the tester light to go out or dim. Repeat the same test with the connector attached to the centre and 15 mm pins. Any dimming or flickering indicates a defect that must be located and repaired prior to use.

12. For the specifications concerning foil bodywires, see Regulations for Competitions, Article 217.

Unlike epee bodywires, where the two sides of the scoring circuit are interchangeable, the foil circuit must be connected properly. The 15 mm pin is always connected to the metallic plastron (alligator clip). The centre pin must be connected to the foil point, running through the centre pin of the bayonet connector (small pin of a 2-pin connector), and the blade wire. The 20 mm pin is connected to the metal parts of the weapon through the outside pin of the bayonet connector (large pin of the 2-pin connector) and the connector mount to the bell guard and blade. It is also connected to the metallic piste through the reels or scoring apparatus (Fig. 11, page 33). Cross-connected foil bodywires can cause major disruptions in competition, since they will pass a simple weapon control, but cannot register a valid hit against the opponent's target. Usually this problem is blamed on the opponent's jacket, bodywire or reel, and several reels are often tried before the President summons a technician.

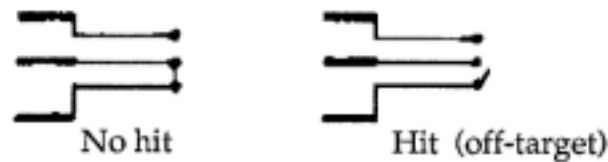

To verify that a wire is or is not cross-connected, connect one side of the tester to the centre pin at the reel end, and then check that there is a complete circuit to the centre of the bayonet connector or the small pin of the two-pin connector. If not, test the other two possibilities (the alligator clip and other side of the weapon circuit) to locate the missing wire. When it is located, it should be disconnected and re-connected to the proper connector (this could be done at either end of the bodywire). Repeat the same test for the 20 mm pin and the other side of the weapon circuit (outside of the bayonet or larger of the two pins), and re-connect that pin, if necessary. A two-way tester simplifies this process, since it permits all three lines to be tested at the same time.

1.2.3.6 Sabre Repair and Maintenance

Until the introduction of electric sabre is complete, maintenance of sabre equipment will remain a relatively simple matter.

The same techniques apply to cutting and bending sabre blades at the time of installation as are set down for foil and epee blades (above), and the assembly of a sabre is similar to that of a manual french foil. The rules governing sabre bell guards permit some eccentricity in mounting, and it is possible to purchase left or right-handed bells, as well as neutral ones¹³. If sabres are to be purchased for club or training use, the latter are preferable, but for individual competitors, bells of the appropriate eccentricity should be used. With the weapon in the en garde position, the blade passes through a right-handed bell to the left of centre, and vice versa, so that the bell extends farther on one side to protect the back of the hand and forearm. This affords a significant advantage, particularly in parrying stop-cuts.

When assembling the sabre, care must be taken to ensure that the blade is cut to the right length so that the end of the tang does not protrude beyond the end of the pommel. Such protrusions are quite capable of inflicting serious injuries when fencing at close quarters. With wooden and hard plastic grips, the tang may be fitted at the time of installation and will not require further attention. With soft plastic grips however, the grip itself will gradually compress during use. As the pommel is tightened to compensate for this, the end will eventually emerge and must be re-cut or ground flush with the pommel. If such grips are to be used, it is a good idea to cut the tang 3-4 mm shorter than required to allow for some of the compression in advance.

The use of a sabre as a cutting weapon also inflicts damage on the edges of bell guards. These are usually made of aluminum, and are easily scored by hard steel blades. In extreme cases, they begin to resemble a fairly coarse-toothed saw, and can inflict injuries. Such bells should be dressed from time to time with a large file to remove burrs and sharp edges, and any that exhibit tearing of the sheet metal itself should be discarded.

13. See Regulations for Competitions, Articles 26 and 407.

1.3. MAINTENANCE OF OTHER EQUIPMENT

Most other personal fencing equipment requires little maintenance, but equipment owned and used by groups or clubs should be inspected regularly and repaired or discarded so as to prevent unsafe equipment from being used by inexperienced fencers.

It is important to stress to fencers that each competitor is individually responsible for his or her personal equipment¹⁴. If it fails to pass a control, it is the fencer who will suffer the consequences, not the coach or technician, regardless of who made the original error. If the equipment was unsafe because of a defect, it is the fencer, not the coach, who risks injury. Therefore, each fencer must be trained to inspect his or her own equipment prior to each competition, and to either make the necessary repairs and adjustments, or to ensure that someone else does. This routine need not be incompatible with the fencer's pre-competition psychological "warm up". On the contrary, if taught correctly it will become an integral part of it. The personal equipment inspection will increase the fencer's confidence in his own equipment, and the regular routine helps to put him or her into a positive frame of mind while waiting for each round of competition to start.

1.3.1 FENCING WHITES

Fencing whites should be checked, especially in the arm and underarm areas for loose or torn seams, or other damage, and re-stitched or patched. If a particular jacket or plastron shows repeated damage, it is too worn for further service and should be discarded. This is particularly true of synthetic materials, which begin to break down after repeated exposures to bleach, detergents, and ultra-violet light.

The F.I.E. and equipment manufacturers have recently introduced the use of Kevlar into the linings of fencing breeches, plastrons, and jackets in an attempt to increase the degree of protection from broken blades. This fibre is many times stronger than nylon, and is used in a number of hi-tech applications, including the manufacture of body-armour for police officers, reinforced plastics for aircraft, and reinforcements for high performance tires. If correctly cared for, jackets lined with Kevlar do indeed afford extra protection, but much of its strength is lost if it is very wet, or exposed petroleum products or ultra-violet light. The manufacturers' instructions for use, storage and washing should therefore be obtained when Kevlar whites are purchased, and should be followed carefully.

14. See Regulations for Competition, Articles 16, 17, and 21.

1.3.2 MASKS

Masks should be frequently inspected for damage to the mesh in the face/frontal area, and for damage to the bib. Often bibs come loose when the stitching holding them to the mask mesh disintegrates. This is a serious hazard, and such masks should never be used, even in practice. Fortunately, this can be repaired with a large needle and sailmakers' thread or twine. Minor damage to bibs can be repaired with adhesive tape (use several thicknesses) on a short term basis, but leather or canvas patches should be used for permanent repairs.

Sabre masks carry extra protection in the form of a leather band around the crown of the mask. This protects the mask itself from metal fatigue from repeated blows from sabre blades, and also protects the back of the wearer's head from "wrap around" hits, where the end of the attacker's blade bends around the rim of the mask and strikes the unprotected area at the back of the head. An ordinary mask can be converted to sabre use by adding such protection, and non-reinforced masks should never be used for sabre fencing, even in practice. Unless a mask is subjected to heavy competition use, it will generally outlast the leather reinforcement. To replace it, obtain a piece of the heaviest leather available, cut it to the desired shape, soak it in water for a few minutes (this makes it flexible), and attach it to the mask with rivets. Usually installing these rivets will deform the mesh underneath, which makes the mask unsafe (and illegal) for later use without the leather protector.

Masks used for electric sabre fencing must not have any insulating surface because they are valid target. This means that the rim surrounding the face area must be made of either lame material or solid metal, generally steel. This must be kept clean (to avoid false non-valid hits) and should be inspected frequently for jagged or rough spots that could cause injury. The bib of the electric sabre mask must also be made of lame material similar to that used for making metallic plastrons. The mask is connected to the metallic plastron by a short wire equipped with an alligator clip which attaches to the plastron collar. This should be periodically checked for conductivity in the same way as for bodywires.

The mesh of masks used for electric foil fencing should be completely coated with an insulating material. This is usually done by dipping the mask into molten plastic after it is shaped. This is to prevent the mesh from becoming valid target in the event that it comes into contact with any part of the metallic plastron during fencing. Occasionally electrical contact will occur when perspiration (which is an excellent electrical conductor) coats the material of the bib, touching the plastron and mesh at the same time as a hit lands on the mesh. The regulations permit fencing with uninsulated masks, except at sanctioned F.I.E. events, but if a touch on an uninsulated mask is recorded by the apparatus, it cannot be annulled¹⁵.

15. Regulations for Competitions, Articles 722 (4) - (5) require insulated masks for A-grade competitions. Articles 722 (6) and 231 (2) - (4) provide that touches that land off-target but register as valid can be annulled, but not in the case of an uninsulated foil mask. Extension of the valid target can also occur where perspiration soaks into the cloth jacket in the areas adjacent to the metallic plastron. Plastrons are made up with a plastic edge beading that is intended to maintain an insulated barrier, but these occasionally become worn, especially in the area where the bodywire clip is attached.

Damage to the frontal area of any mask cannot be repaired, and such masks should immediately be destroyed to prevent their subsequent use in either competition or practice. It is not acceptable to mark such masks with paint, or in any manner that would permit subsequent use¹⁶. It is probably not advisable to routinely test masks with the pressure gauge, since this test contributes to metal fatigue (especially if improperly applied), and most masks are regularly tested at competitions in any event. Each fencer should be trained to visually inspect his mask prior to using it at the beginning of each practice or competition, however, and club masks should be inspected as frequently as possible. Fencers should also be trained to check their own masks during bouts if any severe impacts are sustained.

1.3.3 METALLIC FOIL AND SABRE PLASTRONS

Metallic plastrons are an expensive part of foil fencing, and more recently, sabre fencing, and everything possible should be done to increase their life-span. Apart from the odd tear inflicted by a particularly hard hit, most wear is caused by a mixture of metal fatigue in the lame strands and corrosion. These can be minimised by storing the plastron on a hangar in a dry place. Do not use a metallic plastron at all unless it is required for electronic scoring, and use an old one for practice bouts, if possible. Store it away from wet fencing whites or other sources of moisture, and avoid or minimise folding as much as possible. A recent innovation has been the introduction of plastrons made up of stainless-steel lame fibres, which are more corrosion-resistant and therefore last longer. These plastrons are more expensive, but the increased life-span appears to justify the cost.

Wear or damage to metallic plastrons that causes "dead spots" can usually be repaired simply by covering the damaged area with fresh lame material, and a supply of this material should be maintained for this purpose. Metallic plastrons that are too worn for use in competitions can still be used for practice purposes, but should clearly be marked so as to prevent their use during competition by mistake. To check the overall resistance of a worn jacket, test (using scoring apparatus) by placing a foil point at the areas most likely to be worn out, and at the point of the jacket farthest away from the bodywire connection (opposite shoulder). A marginal jacket can often be made acceptable by folding the material under at the bodywire connection, so that the alligator clip makes contact with the lame fabric on both sides (inside and out)¹⁷.

Plastrons should also be inspected for damage to the interior insulation and plastic edging. These are intended to maintain an insulation barrier between the metallic target and parts of the cloth jacket that can become soaked with perspiration. Since perspiration is an excellent conductor of electricity, the valid target area can be extended onto adjacent areas as the current that indicates a valid touch is conducted back to the plastron and hence to the apparatus, via the perspiration. Where the interior lining is damaged, the wearer can also get electrical shocks through damp clothing. The voltage and amperages are too small to be dangerous, but can be uncomfortable and distracting, especially in competition.

16. Regulations for Competitions, Article 27 (7).

17. The specifications for metallic foil plastrons are found in the Regulations for Competitions, Articles 216 and 722. The specifications for sabre plastrons are similar, except that these are cut to the waist, front and back, and the lame surface includes both arms. Currently the gauntlet, or sleeve portion of the glove must also be covered with lame. The unarmed hand and the hand portion of the sword arm are not covered.

1.3.4 NOTE ON F. I. E. - CERTIFIED EQUIPMENT

The use of maraging-steel blades, stainless steel masks, and Kevlar-lined fencing whites is now mandatory for all F.I.E. sanctioned A grade competitions. Some national federations (notably the Federal Rep. of Germany) have extended this requirement to lesser competitions and even practice sessions. Coaches taking athletes abroad should therefore check up on local regulations and ensure that their fencers' equipment comply with them. F.I.E. certification is indicated by a stamp or label affixed in a prominent place containing the "F.I.E." initials, the manufacturer's name, and the date of manufacture. When purchasing whites or masks, the merchandise should be dated for the current year, as they will become subject to inspection or disqualification after a fixed period.

FIG. 13 TYPICAL F.I.E. CERTIFICATION MARKS



Note : Both carry the dates of manufacture. The black spaces on the Leon Paul mark (left) are for the manufacturer's F. I. E. registration number. The mark at right is the forge mark from a Maraging foil blade.

1.3.5 SAFETY PROCEDURES

Fencing injuries may be caused by unsafe equipment, but they may also be caused by perfectly sound equipment in the hands of persons who are ignorant of, or disregard, basic commonsense and safety procedures. Foils, epees, and sabres are weapons and must be treated as such. They should be stored in secure areas, and in such a way that they will only be in use by beginners when competent supervision is present. Only qualified coaches or senior fencers should have access to the club's equipment, and they must be made to understand that they are responsible for supervising beginners if they release any equipment to them.

Beginners should be taught at the beginning of the first introductory session how to dress, how to carry a foil, and not to handle weapons at all unless masks are worn. They must also be supervised until the coach is satisfied that these rules are being obeyed faithfully. Senior fencers must be aware of the fact that they set an example for the beginners, and also that they should intervene immediately if they observe an unsafe situation. Fencing is extremely safe when compared with many other sports, but the basic nature of fencing assures great public attention when even a minor injury occurs. It is the obligation of every fencer to himself and the sport to ensure that safety rules are obeyed.

II - JUDGING APPARATUS

2.1 INTRODUCTION

The electrical apparatus for judging foil, epee and sabre consists of a scoring machine, two piste cables, two reels, a grounding cable, and a metallic piste. When interconnected properly, the system will accurately transmit hits scored by the fencers to be recorded on the machine, and prevent any hits that may land on electrically grounded surfaces such as the bell guards and the piste itself from being recorded at all. More sophisticated apparatus for use in major competitions may also include additional components to regulate the time of bouts fenced, detect or prevent the fraudulent blocking of foil hits, and repeat the scoring display more visibly for the benefit of officials and spectators.

This Chapter will explain in some detail how to set up and maintain scoring apparatus, and how to isolate and repair problems that may arise anywhere in the system. It is important that the apparatus be viewed as a system, rather than as a group of components, especially when attempting to isolate and diagnose a defect. The system is a single large circuit that begins and ends at the scoring machine, but that runs through a series of reels, piste cables, bodywires, and weapons in between. A break or short circuit at any point in the system may cause a particular set of symptoms, and too often coaches and presidents assume that a particular component is defective without carrying out the necessary tests to prove it. This often results in lost time and will disrupt competition if their assumptions are incorrect. It may also make it impossible for others to properly analyze the problem, once the system is disturbed. If the apparatus is viewed as a system, it can be set up, operated, and dismantled in a systematic manner, which lessens the chances of lost or damaged components, undiagnosed defects and other problems.

It is not necessary that the coach or club technician understand the details of the circuitry of the scoring machine itself. Major problems can and should be dealt with only by competent service personnel. Anyone who understands the sport of fencing and has the most rudimentary knowledge of electricity (not electronics), however, can and should be able to detect and repair problems with the system of which it is a part.

2.2 THE SCORING MACHINE

Increasingly, modern scoring machines are employing solid-state technology, which makes them smaller, hopefully cheaper, and in most cases, less vulnerable to damage. Since they are usually the single largest expenditure for a fencing club, it is well worth while to take some basic precautions to protect them. Unless they are to be kept on the club's premises permanently, each machine should be equipped with a sturdy case, and should be stored in it whenever it is not in use. Impact and vibration can both cause damage, so the case should have an interior compartment, padded with foam rubber to hold the machine. It should fit snugly, and be securely held in place when the lid is closed to prevent interior movement while in transit. The case should also have compartments to hold other parts of the scoring system, if these are commonly transported with the machine. A list of the contents pasted to the inside of the lid will decrease the chance of parts being left behind or lost.

The machine itself is generally equipped to use the ordinarily-available ("mains") voltage, which may range from about 240 volts (parts of Europe) to 120 volts (Canada and the U.S.), but the actual voltage used by the system is 12 V. Each machine is equipped with a power-supply unit (either internal or external) which "steps down" the original mains voltage to 12 V and converts the current from A.C. (alternating current) to D.C. (direct current).

In setting up the power-supply part of the system, it is important to take precautions to ensure that the power will not be interrupted during fencing, especially if the set-up is for an important competition. Extension cords should be secured at both ends, either by tying or with adhesive tape, so that they will not pull free. The last cable should also be anchored to both the apparatus table and the machine, so that tension on it will not pull the machine off the table or disconnect it. If the power supply system is to be used often, it may be desirable to equip the extension cables and wall receptacles with locking plugs, which cannot be accidentally disconnected.

The ultimate safety system is the 12-volt accumulator system, in which mains voltage is fed through a battery charger and into a 12 V battery, which is then connected directly into the machine. This system will keep the apparatus operating even if the power fails, since the battery is still in the circuit. Apparatus is also available with built-in battery supplies, but these must be recharged when the apparatus is not in use. Battery or accumulator supplies are not powerful enough to supply overhead displays. These generally use mains voltage (120 V in Canada) and must be supplied separately if battery apparatus is used. Burglar and fire alarms often employ accumulator systems to ensure that the alarm will function when power is disconnected, and local suppliers of these systems can be a useful source of parts or even complete systems if they must be obtained for major competition.

Older scoring machines are equipped with a ground circuit to protect fencers from electrical shocks. A third wire runs from the machine to the electrical outlet connecting the metal casing of the machine to an electrical ground. This is to ensure that errant electrical current will flow out to the ground, instead of through one of the fencers, if the machine is defective. Usually, when this happens, the fuse or circuit-breaker will quickly interrupt the machine's electrical supply.

**IF THE GROUND WIRE IS ABSENT OR NOT CONNECTED,
FENCERS COULD BE KILLED OR SEVERELY INJURED BY
ELECTRICAL SHOCK.**

This is more of a problem in Europe, where the mains voltage is 220-240V, but the 100-120 volt standards in North America can still cause fatal electroshock, especially in fencers who are exposed because of the excellent contact provided by perspiration-soaked clothing. When installing older machines, check if the power connection has 2 or 3 leads. The North American standard fitting for this is the "3-prong plug" commonly in use. Many European fixtures, however, have only 2 pins, with the third circuit running through the casing of the plug. These must still be grounded. If the machine does require grounding, the entire power circuit back to the wall outlet must be checked to ensure that the ground circuit is not broken. Any 2-wire components in the chain must be replaced. If the wall supply itself is only 2-pin, another, grounded outlet should be found.

Modern machines are designed with double-insulation and other internal protections to avoid electrical shocks, and are not generally required to be grounded.

Perhaps the most basic precaution in setting up a scoring machine, and yet one of the most frequently overlooked, is to set it up in a place where it will be safe from damage by fencers or other passers-by. If the set-up is to be fairly permanent, consider placing the machine up on a wall, out of reach of most weapons, but still close enough to be switched on and off by fencers. If the set-up is for a competition, try to allow enough room between pistes so that each machine is a full metre from the edge of the nearest one.

As stated above, this Chapter will not attempt to teach the reader how to perform sophisticated repairs to scoring machines, but many basic problems may be repairable without recourse to professionals. The scoring display of each machine should contain a total of 8 lamps, split into 4 circuits: green, white, white, and red. Each circuit carries 2 lamps so that the machine will not be disabled if a lamp burns out during fencing. Prior to any competition, machines should be checked for burnouts, and lamps should be replaced to preserve the safety margin. A supply of spare lamps should be obtained and kept on hand for this purpose. Two spare lamps taped to the inside of each machine casing ensures that they will be readily at hand.

If a scoring machine cannot be switched on, it is possible to check the power supply area for major faults, such as broken wires, defective switches, etc. Make sure the power is disconnected before removing the cover, and give these components a visual inspection. The fuse or circuit-breaker should also be checked. Remove the fuse from its holder, and connect each end to one side of a tester. If there is current flow through the fuse, it is OK, if not, it must be replaced. A circuit-breaker is usually reset by pressing a button. If either of these components are the cause of the problem, consider what may have made them blow in the first place before resetting/replacing. In some cases, fuses will blow simply from overheating during prolonged use, or from mechanical shock from impacts. Another possibility is a power supply short circuit. These will usually be visible as a burnt mark somewhere inside the casing. If so, the short must be repaired before the machine is reconnected and switched on. If no reason is evident, and the fuse or breaker opens a second time, professional attention is required.

The internal components of a solid-state machine are usually mounted on one or more P.C. (printed-circuit) cards, which are connected to the rest of the machine by a multi-circuit fitting at one edge. Often, when a machine displays several major malfunctions at once, it is because one of these connectors has come loose or shifted. This problem is particularly likely after a machine has been dropped or subjected to other types of impact. Briefly wiggle the fitting, ensuring that it is securely fastened to the card's edge, and that all of the contacts line up with their counterparts on the card. If this causes the machine to function, but only intermittently, it may be that the connectors are loose or that the contact surfaces on the card have oxidized. Try bending each contact in slightly (use a toothpick), and rub the contact surfaces on the card itself (lightly) with a pencil eraser to clean them. If this does not rectify the problem, professional attention is required. If it is necessary to ship P.C. cards back to the manufacturer, ensure that they are well packaged and protected from heat, pressure, impact and so forth. If possible, obtain special packaging materials designed for this purpose.

If the machine is equipped with overhead/repeater scoring displays, these must be securely mounted to the apparatus table, and correctly connected to the machine itself. These displays are usually about a metre in height, and may weigh up to 30 kg, and should therefore not be used on a small or unstable base. Too often, such displays are securely attached to a small table, and the whole system capsizes when hit by a passing fencer. Consider also the fact that these displays require much more power than the scoring apparatus itself, since they have large lamps for visibility. An ordinary machine will draw no more than 50 Watts, which means about 30 of them could be run from a single 15 Ampere (standard for domestic use) circuit. Overhead displays, however, may draw up to 400 Watts, which means that 3 or 4 of them could blow a 15 amp breaker or fuse, if all of the lamps come on at the same time. If a large number of displays are to be used, they must be split up onto separate circuits.

Circuit breakers or fuses are calibrated in Amperes (A, or "amps"), a measure of the amount of electrical current which will pass through a circuit without causing the wires to overheat. The fuse or breaker is a safety device, designed to interrupt the flow of electricity before such overheating can occur. The amount of electricity actually required to operate a device is usually given in Watts (W), so it is often necessary to be able to convert one unit to another when setting up large competitions. To do this, the electrical voltage involved must also be known. The number of watts required will be equal to the number of volts multiplied by the number of amperes (Ohm's Law), expressed as $V \times A = W$. Thus, for example, at 110V, each ampere of current will provide 110W of power. A typical household circuit in Canada is fused at 15A, and carries about 110 V, for a total of 1650W. If the appliances on that circuit draw more than 1650W, the circuit will be overloaded, and the fuse or circuit breaker will blow, interrupting the power. In effect, the fuse overheats at a lower amperage/wattage than the surrounding wires.

The wattage of most electrical scoring apparatus should be marked on the casing it will either be stated as the number of amps or watts required. Note that if it is expressed in amperes it will not be correct in North America if the figure was calculated for Europe. A device that draws 2 amps in Germany, where the voltage is 240V requires $2 \times 240 = 480W$. In Canada, where the mains voltage is only 120V, 480W requires 4A, not 2A. As the voltage is halved, the amperage doubles. The wattage for a given device will remain fixed.

Level IV - Armourer

Generally, the wattage required for scoring apparatus will be quite low (less than 50 W), and large numbers of machines can be placed on a single 15A circuit. Overhead apparatus however, draws much more power, and a calculation should be done if a number of pistes will be so equipped. The wattage will not generally be marked on these devices, since it varies depending on the lamps used, which can change. Simply add up the total of the wattages of the individual bulbs. A scoring display with 8×50 W lamps to indicate hits and 24×5 W lamps in a scorekeeper, for example, has a maximum possible wattage of 420 W, if all of the lamps are on at the same time.

If the circuits supplying a gymnasium will carry 1650 W, three such displays (1260 W) can be connected to it at once. It is generally wise to allow some leeway in this calculation (called "headroom"), since fuses or circuit breakers are not always precisely calibrated, especially if old. Also voltage is not always consistent. Actual voltage delivered at an outlet may vary from about 105 to 12 V. At 105 V, a 15 A circuit would only carry 1575 W. If a large, modern venue is chosen for a competition, the standard circuits may carry 20 A (2200 W at 110 V). It should also be borne in mind, however, that some fuses or breakers may service more than one receptacle. Do not assume that plugging apparatus into different wall outlets has automatically put them onto different circuits. It should also not be assumed that only scoring apparatus will be connected. A competition may run smoothly for hours, only to have half the apparatus go dead when a custodian switches on a floor polisher down the hall. For large competitions, the circuit distribution should be checked with maintenance staff.

Some common Voltage/Amperage/Wattage figures are as follows.

	5 A	10 A	15 A	20 A
North America (110 V)	550W	1100 W	1550 W	2200 W
Europe (220 V)	1100 W	2200 W	3300 W	4400 W

2.3 THE PISTE CABLES

These are identical to epee bodywires except that they are long enough to run between the scoring machine and the reels at either end of the piste. They should be not less than 10 metres in length (12 m is preferable), and of the most robust construction possible. The wire itself can be as fine as #22 (AWG)¹⁸, but heavier wire (#16-18) stands up to prolonged abuse better. Finestrand wire (i.e.: where each 22 gauge conductor is made up of many fine strands) is also preferable, since it is less subject to metal fatigue. The two end connectors should be of the hard case type, and the insulation should be reinforced at the back of each connector to provide strain relief. This should be strong enough that tension exerted on the wire is transferred to the casing of the connector rather than the electrical connections themselves. Otherwise, there will be broken wires or short circuits every time someone trips over the cable. The connector pins should be inspected frequently and adjusted to ensure a snug fit when plugged in. These have a tendency to relax after a period of use, and must be expanded again (use a knife blade or small screwdriver). If a pin becomes difficult to adjust in this manner, it should be replaced.

Each piste cable should be inspected at least once per year, and more frequently, if they are used in competitions. Connect one end to a tester, and short across each pair of contacts at the other end, verifying that there is a complete circuit through each line, and that there are no cross-connections. Check for broken wires (this usually occurs at or near the ends) or loose connections by shorting the contacts at the end opposite the tester, and stretching and wiggling each plug. Any flickering of the tester lamps indicates a problem which must be located and repaired.

Piste cables should be coiled into a figure-eight shape for storage, and not wound tightly around the arm. Coiling on the arm puts twists into the cable, especially the 3-wire flat cable popular with European manufacturers, which eventually cause breaks in the wires. Both ends of the cable should be secured to reels, apparatus tables, or other solid objects while in use, to avoid accidental disconnection.

18. American Wire Gauge. This is the standard for measuring electrical wiring in North-America. It runs from 0 to 40 AWG, with the size of the wire decreasing as the numbers increase. A heavy extension cord, suitable for carrying 15 amps for up to 15 metres would be 14 AWG, 3 conductor (#14-3). Most piste cables and bodywires are made using #16-20 AWG wires. This is far in excess of the size needed to carry the small electrical currents required, but stands up better to mechanical abuse and metal fatigue.

2.4 THE REELS

ESCAPING REEL SPRINGS CAN INFLICT SEVERE EYE INJURIES. SUITABLE EYE PROTECTION MUST BE WORN WHENEVER OPEN REEL CANISTERS ARE HANDLED.

Reels are subjected to considerable wear and tear in the course of routine practices and competitive fencing, and require frequent maintenance. Even the most sophisticated of this maintenance is not difficult and most tasks can be done with only basic tools. There are two types of reels currently in common use, and these will be dealt with separately. The older design, the horizontal axis reel, is typified by the Leon Paul and old-style Uhlmann reels common throughout Canada. It involves a shaft running horizontally between two casings, with a spool running on it to carry the reel cable, and a set of brass contact rings and brushes to transfer electrical current from the revolving spool to the reel casing. The newer design involves a spool mounted on a vertical axle which is supported by a single bearing at the bottom. Electrical contact is made through a pair of brass cylinders placed at the centre of the axle on the side opposite the bearing. This type of reel is currently marketed in Canada by Allstar and Uhlmann. It is easily recognized by its flat shape and low profile. A third type was imported into Canada during the 1960's and '70's that involves a fixed spool onto which cable is wound and unwound by a revolving cursor. These have not stood up well to sustained service, and are no longer common in Canada.

All reels should be subjected to a cursory electrical and mechanical inspection twice per year, and prior to use in any competition. Electrical inspection of the reel is much simpler if a twoway electrical tester and an epee bodywire are available. A fencing reel is composed of three separate circuits running from the end of the fencer's bodywire to the jack where the piste cable (running to the scoring machine) is plugged into the side of the casing. Mechanical problems arise when the reel will not retrieve, usually because the cable has fouled somewhere inside, or a spring has broken. Electrical problems arise as either open circuits, where electrical current will not flow through one or more of the three circuits, or short circuits, where current flows from one circuit to one or both of the others when it is not supposed to.

Begin by testing for short circuits. Connect the tester to the stationary jack on the reel. Pull 10 metres of cable off the spool, working it back and forth, while observing the tester lights. If any come on, even briefly, there is a short circuit somewhere in the reel which must be located and repaired. Make a note of which lines are shorting together to facilitate this when the reel is taken apart.

If no short circuits are indicated, take a test cable and connect the centre and 15 mm plugs together at the end of the reel cable (this is the epee scoring circuit). Move the cable in and out, checking for any flickering of the light that would indicate a break in the circuit.

Repeat the same test for the foil side (centre and 20 mm plugs). If no defects are found during this procedure, the reel is satisfactory for use in competition. If routine maintenance is to be done, the reel should also be cleaned prior to returning to service. This is done by simply opening up the casing and blowing or sweeping dust and debris from inside. Large amounts of dust accumulate in the bottom of the casing, being swept in by the reel cable each time it is retrieved. In horizontal axis reels, the three brass contact rings inside the spool should also be wiped clean and the alignment of the brush contacts checked. This is done to remove tiny brass particles that accumulate and can cause short circuits between the rings.

2.4.1 THE HORIZONTAL AXIS REEL (Fig. 14, page 49)

To disassemble the reel, it should be clamped into a vise, if possible. Adjust the vise jaws so that they grip the hex nut on the side of the axle opposite the connector, with the connector facing up. Take a wrench and remove the retaining nut on the connector side, along with any lock washers that may be present. Set the nut aside. Grip the end of the reel cable, and lift the top casing away from the reel. The cable must be held to prevent the springs from relaxing too quickly when it is freed. Release the tension by unwinding slowly once the reel casing is clear.

If the reel is an old-style Uhlmann reel, the connector is permanently mounted on the casing, and it will be necessary to reach inside to remove the set screw that attaches the connector to the axle and to slide the connector off the axle as the reel casing is lifted clear. The connector then comes away with the casing. On Leon Paul reels, the connector is a separate unit, and can be removed after the casing is off. To remove it, reach into the reel, and lift all three pairs of contact brushes away from the brass rings, then slide it off the end of the axle. The spool unit may now be lifted carefully off the end of the axle. The three spring canisters underneath should not be disturbed by this, but occasionally a spring gets loose during this procedure, especially if all of the tension was not slacked off previously. For this reason, eye protection should be worn. When the spool is clear, the three spring canisters can be lifted clear of the axle, one at a time. The reel casing should be cleaned as thoroughly as possible prior to reassembly. In particular the dust residue (swept in from the floor by the cable) should be removed from the spool area, and the residue of brass particles that collect on the brush rings should be wiped away (this can cause short circuits between rings).

If the problem is an electrical short circuit (tester light comes on when it shouldn't), the most probable locations are at or near the fencer end of the cable, and the brush ring assembly. Begin by connecting the tester to the fencer end of the cable, and disassembling the reel. If the light goes out when the brush assembly is lifted clear, the short is there, if not, check the other end of the cable. If the problem is in the brush assembly, check all brushes for alignment (one may be out of position and touching two rings), and realign if necessary. Brush away any brass residue that has collected between rings, and check for burrs or metal fibres that may be touching two rings at the same time.

If the problem is at the fencer end of the cable, open the connector unit, and look for obvious crossovers of the wires concerned. Wiggle the connector around and attempt to locate the fault. As a last resort, cut about 10 cm of wire from the end of the cable and rewire the end unit completely (most reels require this annually anyway).

If the problem is an open circuit (tester light will not come on), the procedure is the same, but the problem is less likely to be at the brush assembly, so the fencer end of the cable should be checked first. Isolate the cables on the tester and determine which one(s) are broken. It may be possible to determine the precise location of a break using a tester probe sharp enough to prick through the wire's insulating sleeve, although this is usually not practical if the break is very far up the cable. If the break is not found close to the fencer end, test the first 15 cm of the other end, since breaks may occur here when a fencer fleches off the far end of the piste. If the break is in the middle of the cable, it must be replaced.

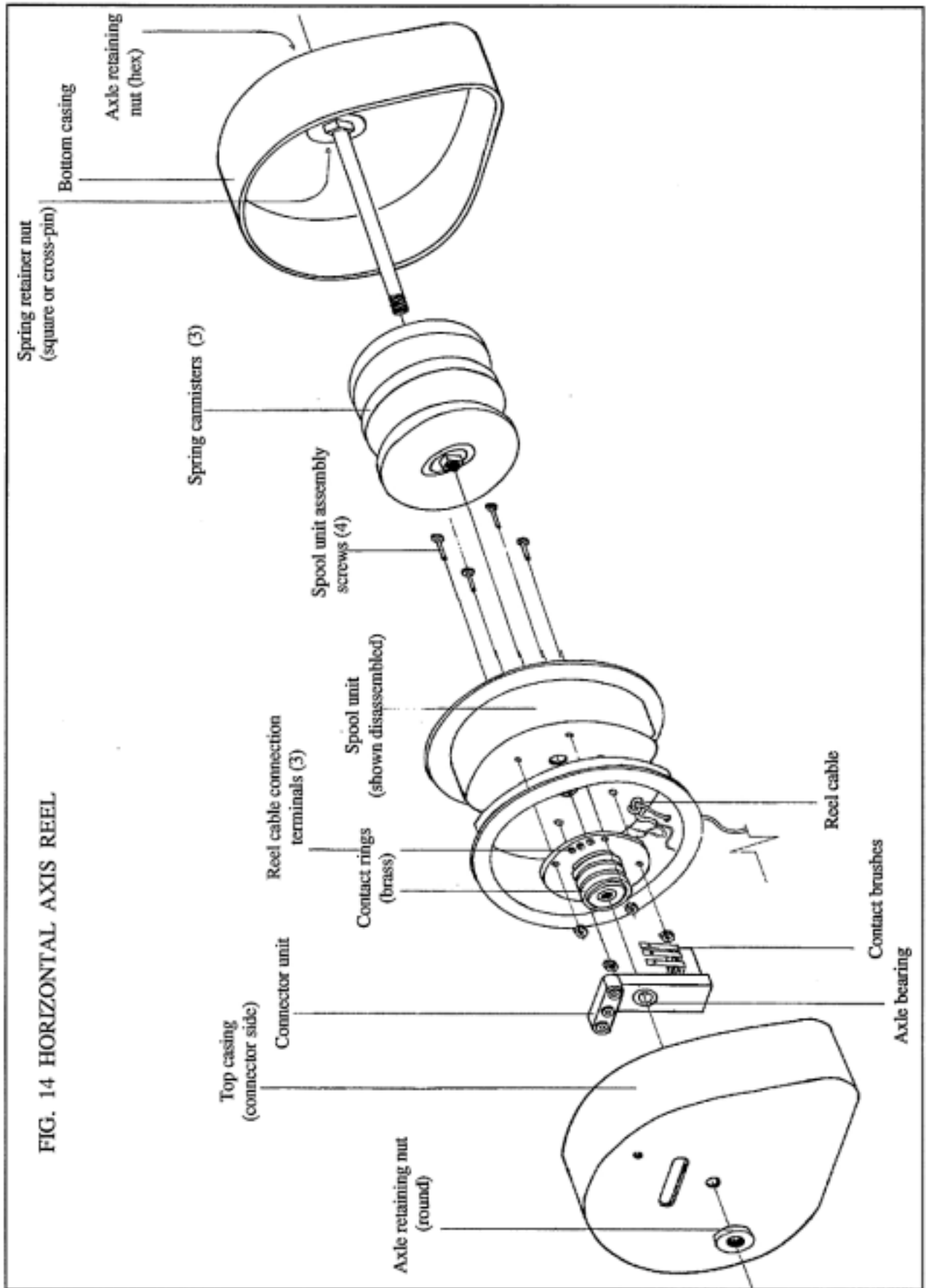

If the problem is mechanical (reel won't retrieve), the cause is usually either a tangled cable or a broken spring. A tangled cable is easily spotted and cleared once the reel casing has been removed. Broken reel springs are more difficult to fix. Begin by disassembling the reel and removing the 3 spring canisters. Remove the top of each and inspect the springs for breaks. All three should be inspected, since a broken spring releases the tension in the others, often bending or breaking them as well.

Springs that are broken at the centre end can be repaired by lifting that end out of the canister, cutting it square, and punching a new hole. A small clamp should be placed on the remainder of the spring to prevent it from escaping while this is done. A small (1") "C" clamp or small pair of vise-grips is ideal for this task. The end of the spring can be made easier to punch or drill by heating the last 3 cm red hot, and then allowing to cool. This burns the temper out of the steel, softening (annealing) it. A simple punch can be made from a piece of scrap steel and a drill press, if one is available. If not, it may be worthwhile to have a local machinist make one up. If a punch is not available, the hole can be drilled, provided the spring end has been annealed first.

Newer reel springs are not anchored by screws, but by folding the ends into notches in the casing and centre unit. To repair these, simply trim the end of the spring square, heat to anneal, and bend into the necessary shape. If the bent end tends to straighten out in use, re-heat the end after bending (red hot) and quench in water before reassembly. This hardens the steel again so it will not unbend, although it does become brittle and may break. In general, the faster it is cooled, the harder and more brittle it becomes.

A break at the outer end of the spring is only slightly more difficult to fix. If possible, tease the spring up slowly until it is about halfway out of the canister, and clamp with a small "C" clamp or vise-grips. Then remove it, repair the end, and re-insert the same way. If this cannot be done (it takes practice), remove the spring, allow it to relax (carefully), repair the end, and rewind into the canister.

The process of rewinding a reel spring becomes surprisingly easy if the following procedure is used. Obtain a piece of 3/8 inch threaded rod about 15 cm long, with 4 hex nuts and two washers. Clamp the rod in a vise (vertically), with 2 nuts locked together about 3 cm below the top end. Place the spring canister on the rod with a washer below and above it, then clamp it in place with the other 2 hex nuts. These should be tight enough to hold the canister firmly, but not so tight as to prevent it from turning.

Place the repaired (outer) end of the spring into the canister and secure it with the screw. Check that the spring is installed in the right direction. This may be done by comparing another spring from the same reel. Grasping the spring firmly with one hand and the canister rim with the other, wind the spring into the can, using the other hand to keep it from lifting out. The can must be allowed to revolve slowly as the spring is wound in. With a little practice, a spring can be removed, repaired and rewound in this manner in as little as five minutes.

2.4.2 THE VERTICAL AXIS REEL (Fig. 15, page 52)

The reel cable assembly of these reels is identical to the older horizontal axis units, and the electrical testing/diagnosis procedures are the same. Begin by connecting the reel to a two-way tester, and operate it in and out with the fencer end open (to check for short circuits) and then with the 3 terminals connected (to check for open or broken circuits). If an electrical problem is located in the cable or at the fencer-end connection it can be repaired in the same manner as for horizontal axis units.

If the problem is mechanical in nature, or is electrical, but inside the reel, it must be disassembled. Begin by locating the top casing screws at the bottom of the reel, and remove these. Lift off the top of the casing itself, exposing the top of the cable spool. The spool is under tension from the springs below, and must be unwound to avoid damage. Grasp the fencer end of the cable as the top is lifted off the reel, and allow the spool to revolve slowly until all of the tension is out of the springs. It is a good idea to strike the bottom part of the reel against the workbench as this is done, since spring units may stick.

Opening the casing exposes the inner end of the reel cable, which permits additional electrical testing. With the tester still connected to the reel, short circuit the inner ends of the cable, which are located on the connecting block on the side of the spool. Try all of the possible combinations. One wire is connected to the reel itself, usually by contact with one of the screws that holds the spool in place. This is the "ground" wire, which corresponds to the 20 mm terminal on the reel base (and also to the connection for the fencing piste, if there is one). The other two must be determined by process of elimination.

If the circuit is "clean" (i.e.: no shorts or breaks) between the base of the reel and the inner end of the cable, the fault has been isolated in the cable itself. If not, a problem in the reel has been located, but this does not necessarily eliminate the cable, since there may be two separate problems. Test the cable separately by connecting the tester to the fencer end, and repeating the same tests at the connecting block at the spool end.

If a short circuit is located within the reel, connect the tester to the jack on the bottom of the casing. Remove the screws from this connector and inspect it for open or short circuits. If none are found, remove the contact assembly by backing out the retainer screw. Watch the tester as this is done. It should go out as the contacts are removed, and if it does not, the short circuit is in the assembly itself. Pull the pin from the assembly and remove the inner contacts. Inspect each for burrs of metal or faulty connections that could short from one connector to the other. Also check for broken wires or connections that could cause open circuits, and make any necessary repairs. A similar procedure should be followed for isolating open circuits, except a screwdriver or other metal tool is used to deliberately cause short circuits through each component of the reel, until one is found that does not conduct electricity.

If the problem appears to be further inside the reel, remove the retainer screws and lift the cable spool clear. Be sure to check that there is no remaining tension in the springs before this is done. This exposes the retainer screws holding the lower (spring) casing unit in place.

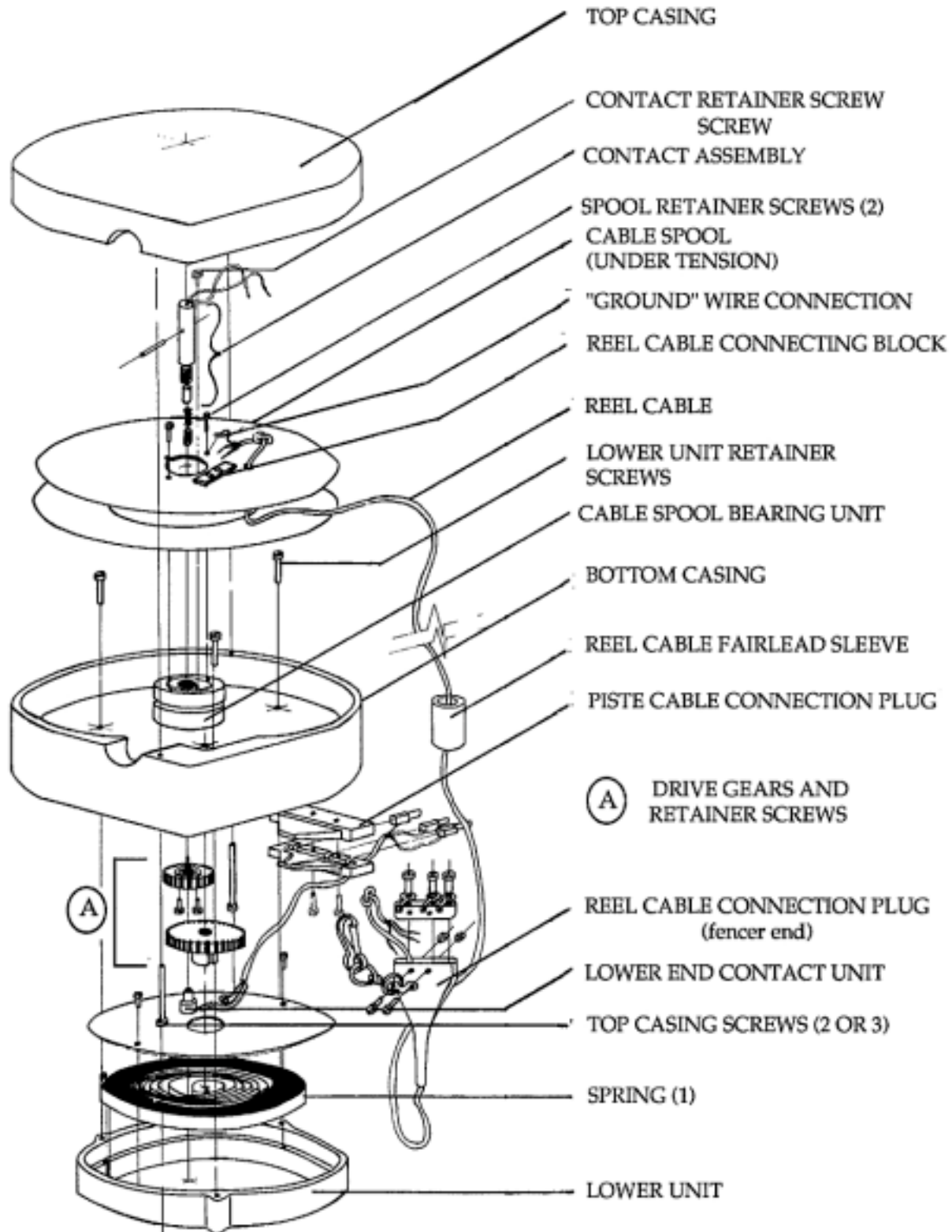

Fig. 15 VERTICAL AXIS REEL
(Allstar, Uhlman)

Remove these, and separate the lower unit, sliding the drive gear(s) out of their positions. Set the rest of the reel aside, and examine the lower unit. The wiring between the lower end of the contact unit and the lower (piste cable) connector will be exposed. Test it for short or open circuits in the usual manner.

Mechanical problems in this type of reel most commonly result from tangled reel cables. Reel springs seldom break because of the gear reduction system, which reduces wear. A jammed cable will be obvious once the upper casing is removed (remember to hold onto the cable to prevent the spring from unwinding too quickly). Avoid using force to clear it, since this may damage the wiring. If it will not come free easily, unwind the spool to relax the spring tension, remove the two spool retainer screws and lift the spool free to clear the wire. Often the wire will come free during the unwinding process.

If the reel appears jammed, but the wire path is clear, check the reduction gear area for debris that may have been jammed in the gears, and for damage to the gears themselves. Clear the area and replace any damaged gears. New gears should be re-lubricated with a suitable grease (for nylon gears). This can be obtained from any store that sells parts for standard household appliances.

If the reel operates freely, but will not retrieve, the spring has broken or come free at one end. Open the casing, visually inspect and remove it. It may be possible to trim a broken end, heat it (to anneal) and re-form it into the necessary shape so the spring can be re-used, but this will likely only be a stop-gap measure until a new spring can be obtained. If large numbers of these reels are in use, it may be advisable to obtain a couple of spare springs and keep them with other parts to permit speedy repairs to be made.

Early Allstar versions of this reel design (Fig. 15, page 52) employed aluminum fairlead sleeves, which are rapidly worn away by friction with the passing cable. Eventually the cable will either cut through the sleeve entirely or produce a sharp surface that then cuts the wire. Later models corrected this by exchanging the aluminum sleeve with an identical one made from low-friction Teflon. Aluminum sleeves should be replaced with teflon ones before they damage the reel cable, if possible.

2.5 OVERHEAD CABLE RETRIEVAL APPARATUS

("Bungie" cords) (Fig. 16)

Bungie-cord apparatus consists of a length of "bungie" (elastic) or shock cord running the length of the piste and through small pulleys fixed to the floor or ceiling behind it. The ends of the cord are then fixed to pulleys through which the cables pass, between the scoring apparatus and the fencers. Thus, as the two fencers move up and down the piste, the bungie cord itself shifts in the opposite direction, and any changes in the distance between them are taken up by the elasticity of the cord itself. This apparatus may be used to replace reels and piste cables in many situations.

Fig. 16 BUNGIE CORD APPARATUS (Overhead configuration)

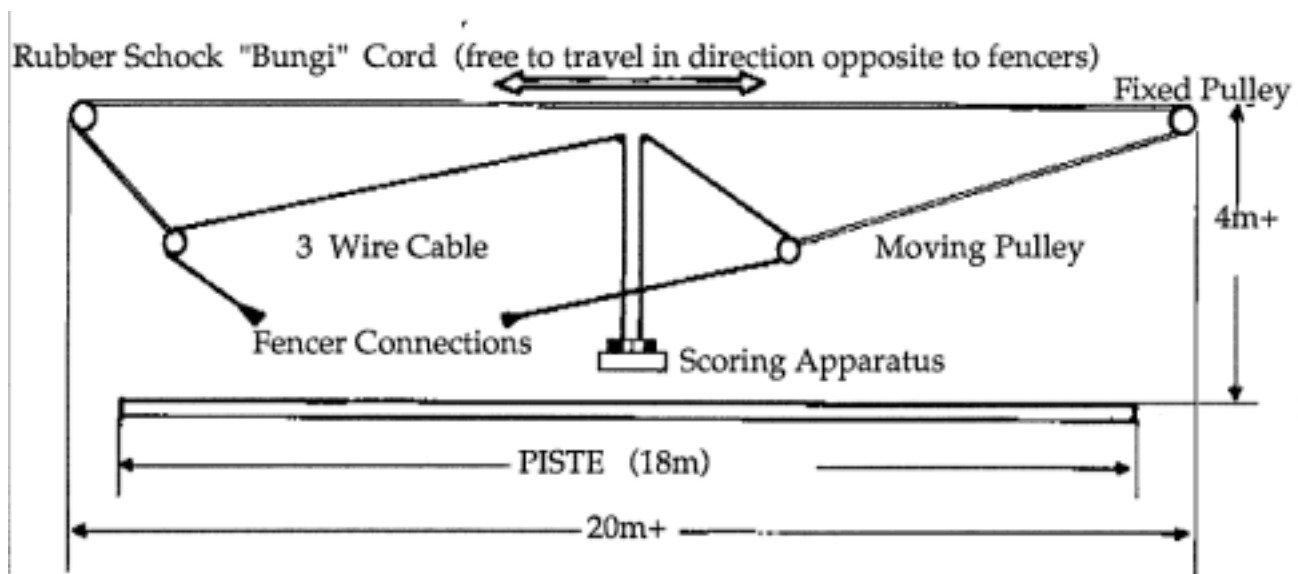

Bungie-cord apparatus has both advantages and disadvantages when compared with conventional reels and piste cables. It is much less expensive than reels and takes up much less space and weight for transport, but requires much more skill to set up and dismantle properly, particularly if this is done on a regular basis. Proper installation is important, because the bungie-cord resembles a large slingshot. If cable-ends escape, they can travel across a gymnasium in fractions of a second and inflict injuries on anyone who gets in the way. This is a particularly serious consideration for overhead installations, where the cables may fly at eye-level.

If this apparatus is set up at floor level for temporary use, positioning of the two anchor-points is also important. These should be at least one metre away from the lateral boundary of the piste, and at least one metre behind the ends, including any warning or run-off areas. This minimises damage caused by fencers tripping over wires, and also opens up the angle between the two halves of the cable, making it less likely to twist or foul in use.

Fig. 17 BUNGIE CORD APPARATUS

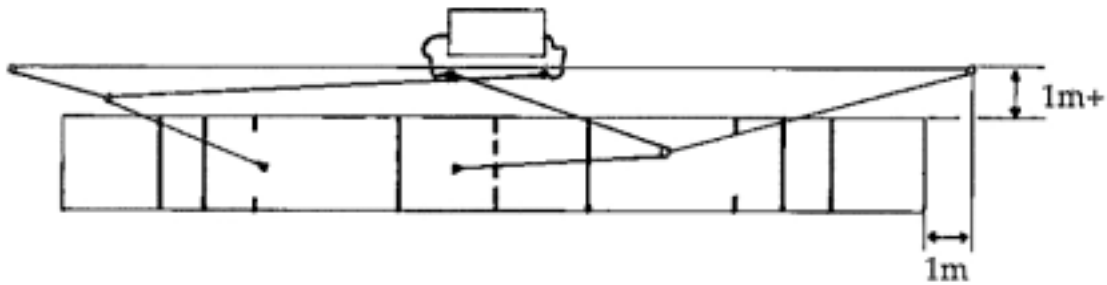

Bungie cord apparatus is fundamentally different from reels in that the fencers are ultimately anchored to a point beside the piste, usually the table holding the scoring apparatus, by a fixed length of non-elastic wire. The elasticity in the system changes the length of the bight in the cable, but if either fencer fleches far enough beyond the end of the piste, this bight vanishes, leaving the fleching fencer attached to the table by a fixed length of cable. Where an ordinary reel would be dragged across the floor, the apparatus table will not be. The result is usually either a broken cable, or damage to the scoring machine when the table is dragged from under it.

For this reason, bungie-cord apparatus is not recommended for major competition use. If it is so used, there should be enough space to permit anchor-points at least 3 meters behind the piste, and cables must be long enough to permit fencers to reach a wall or backstop before running out of elastic. If the cable ends are to be tied off to the legs of the apparatus table, the margin of safety can also be improved by tying each to the leg at the opposite end of the table. Thus the cable running to the left-hand fencer is tied to the right-hand table leg, and the margin of safety is increased by the length of the table itself. Anchoring the cables to a rigid point on the floor instead will protect the rest of the apparatus, but will result in a severely damaged cable if too much tension is applied.

If it is to be set up and dismantled often, the bungie cord and two cables should be separated and coiled carefully in a figure-eight, not a circular coil. Coiling in circles introduces twists into the system that will damage the cables and cause the bungie-cords to tangle during subsequent use. A figure-eight coil involves a series of twists in alternate directions, which then cancel each other out when the cable is uncoiled again.

2.6 TROUBLESHOOTING ON THE PISTE

2.6.1 GENERAL NOTES

Locating and repairing any problem is the ultimate test of the technician's knowledge of fencing equipment. It is here that experience and the overall view of the equipment as a single system are most important. Many problems, such as broken reel cables or springs will be obvious at the outset, but most electrical faults will not. The coach or technician cannot assume anything when summoned to a piste where there is a malfunction, especially if others have attempted to repair it before he or she arrives.

As a coach, one should not interfere with the actions of a President or Technician attempting to diagnose the problem, but their actions should be observed to protect the interests of the fencer(s) involved. Judgment and integrity are important: one should be ready to assist or make suggestions if something has been overlooked, but avoid interfering or impeding the repair process. In any event, the coach should have a clear idea of the facts involved and the probable nature of the fault before intervening.

If asked to assist, begin by ascertaining what the nature of the trouble is from the fencer affected or the President. If possible, reproduce the fault while the President is observing, and prevent the removal or adjustment of any equipment until this is done, as adjustments may prejudice the right of a fencer to have a suspect hit annulled¹⁹.

If attending as a technician, it is important to control access to the piste: exclude everyone but the President and fencers. It is impossible to systematically trace a fault with others on the piste attempting to do the same thing. Find out what, if any, actions have already been taken. Components that have been removed may contain valuable clues, and the replacements may have faults of their own that will only confuse things further.

If the location of the trouble is not obvious, a system for tracing it must be applied. It is best to treat the circuit as a loop beginning at the scoring apparatus, running to the tip of the weapon, and returning to the apparatus. Since both sides of this circuit can be examined together, and the weapon is the most frequent location for problems, start there and work back towards the scoring machine. Isolate the components one by one, and try to restore the circuit with them taken out. When the apparatus responds properly, the last component removed was probably the location of the fault (assuming that there was only one fault, which may not always be the case). Once located, the defective component can be replaced and fencing resumed, although there should be continued surveillance in case another defect has gone undetected, masked by the first.

19. Regulations for Competitions, Articles 73, 231 (3), (4) (foil), and 326 and 327 (epee).

2.6.2 TROUBLESHOOTING FOIL APPARATUS

The foil circuit is normally closed, and opens to trigger a non-valid hit on the apparatus. If a second circuit between the point of one fencer and the target of the other is closed at the time the trigger circuit opens, a valid hit is recorded instead. Therefore, if hits will not register, there is a short circuit somewhere, and if there is a constant non-valid registration, there is an open circuit somewhere.

Begin by disconnecting the foil that is not working: there should be a steady white light on that side of the apparatus. If there is, create an artificial short circuit by connecting the two sides of the bodywire together (touching both to the bell guard of the disconnected foil will do nicely). This should cancel the off-target signal. If both tests are satisfactory, the problem has been isolated at the foil; it should be replaced and fencing resumed.

If there is no off-target registration when the foil is disconnected, there is a short circuit farther up the circuit, and if the off-target registration is not cancelled when the end of the bodywire is shorted out, there is an open circuit farther up. The same tests should be repeated by disconnecting each additional component, observing the registration with the circuit open, and then with the correct wires shorted out. In order, the test should be repeated at the reel end of the bodywire, the connection between the reel and the piste cable, and the connection between the piste cable and the machine. The foil target circuit runs through the centre and 20 mm pins of the bodywire (Figs. 11 & 12, pages 33 & 34).

When the defect is isolated, the component should be removed, marked as either open or short circuit, and replaced. It is useful to have a system for labelling defective equipment, either by tying a knot in a cable or tagging, so that it will not turn up on another piste before it can be repaired.

If the defect is causing the target of one fencer to register non-valid hits, the other part of the circuit, which runs back to the apparatus through the metallic plastron and opponent's bodywire, must be tested. Begin by testing the metallic plastron itself for "bald" spots, where the lame material is too worn to conduct electricity. If the apparatus is not equipped with antifraud circuitry, this may be done by placing the opponent's bell guard (which is grounded) against the plastron while making hits in the suspect area with the point. Since any bald spots will be insulated from the foil bell as well as the apparatus, they will usually (but not inevitably) register as not-valid hits. If a bald spot is detected, the plastron should be confiscated and marked as defective by the technical staff.

Before doing this, however, it is important to consider that the fault might be farther up the circuit, especially if hits everywhere on the plastron register as non-valid or if a visual check reveals no worn spots to account for the problem. Test each component in turn by placing it against the point of the opponent's weapon and depressing. Repeat the same test at the alligator clip, the reel end of the bodywire, the reel end of the piste cable, and the input plug of the scoring apparatus itself. The target circuit in foil is the wire connected to the pin that is 15 mm from the centre pin (Fig. 11, page 33).

If hits against this wire continue to be non-valid all the way back to the scoring apparatus, there is a cross-connection on the other side of the system, most probably in the bodywire of the fencer scoring the non-valid hits. Place his bell guard against the opponent's metallic plastron and depress the point. Since the wire that should have been connected to the point is connected to the bell guard instead, the apparatus should record this as a valid hit. If it does, replace the bodywire and confiscate it for testing. This problem is very difficult to trace, and should be suspected where the fencer has changed bodywires since his last bout, or where the trouble arises at the beginning of the first bout of the day. It is easily verified by connecting the suspect wire to a two-way tester. Touch the alligator clip to the tip of the bayonet connector or small pin of the 2-pin connector. If the "epee" circuit light comes on, the wire is connected properly. If the light comes on when the outer rim of the bayonet connector or large pin of the 2-pin connector are touched to the clip, the wire is cross-connected.

2.6.3 TROUBLESHOOTING EPEE APPARATUS **(Figs. 9 & 10, page 22)**

The system for locating epee faults is the same as for foil: begin at the weapon, and work back towards the apparatus. Since the scoring circuit is normally open, and closes to trigger a hit, however, the tests for short and open circuits are reversed. If no hit will register, there is an open circuit somewhere; if a hit is constantly registered, there is a short circuit. In epee, the third wire is used to connect the bell to the grounding circuit of the apparatus, so hits recorded on the bell (which should have been cancelled) indicate a break in that line somewhere.

If a hit is constantly recorded, disconnect the suspect weapon. If the short circuit is there, the apparatus will reset as soon as it is removed, if not, repeat with each piece of equipment back to the apparatus until the fault is located. If no hit will register, disconnect the epee, and create a short circuit across the target lines for epee (centre and 15 mm pins) at the end of the bodywire. If this triggers a hit, the fault lies in the epee, if not, repeat the same test at each location (above) back to the apparatus. When the component with the broken or open circuit is removed, the scoring circuit will close and a hit will register.

The bell guard is grounded to the apparatus through the wire 20 mm from the centre pin of the bodywire. If hits are recorded against the bell, check it for oxide or other insulating material first. If none is found, disconnect the weapon and place the opponent's point on the 20 mm pin of the bodywire. If a hit registers when the point is depressed, the break is farther up the circuit. Repeat the same test at each break until the defect is eliminated.

2.6.4 INTERMITTENT AND MULTIPLE FAULTS

These are more difficult to analyze because there is no system that is completely assured of locating them. Multiple faults will eventually be detected when problems remain after one defective component has been replaced. Only experience can locate a fault that refuses to occur when the technician is present, however, and there is no substitute for this.

If the problem will not re-occur, get as much information as possible from the President or fencers, and consider what could have caused it. Would it be an open circuit or a short circuit? Did it afflict a particular fencer (this suggests personal equipment), or all equally? All of these suggest particular locations for the problem. If several locations are suggested by the information, begin by inspecting the highest-wear locations first. An intermittent off-target at foil, for example may be caused by a loose point (barrel), but if it seems to occur only when the fencer was attacking (i.e.: when the tension on the reel cable and bodywire are maximized), the bodywire and reel should be checked.

TASK #2 - COMPETITION

Candidates must become sufficiently competent to be able to plan, conduct, and report on a provincial championship level competition, consisting of at least two days of fencing, four events, and with a minimum total entry of 120 fencers.

Need to Know

1. Candidates must be able to set up an organising committee and assign specific responsibilities to the members according to their capabilities. Specific assignments may include: registrations, public relations, apparatus, venue, fundraising, treasury/accounting, and directoire technique.
2. Candidates must be capable of devising and implementing a registration system for the competition. This includes drafting and printing a registration/entry form, taking registrations at the door, collecting and accounting for entry fees, verifying rankings and affiliations of fencers, and digesting and transferring information to the Directoire Technique for use in composing preliminary pools.
3. Candidates must be able to choose a venue based on its advantages or disadvantages relative to other possible locations, lay out an efficient floor-plan, and make any other pre-arrangements necessary to make the best possible use of the facilities available.
4. Candidates must be able to locate and obtain sufficient equipment to stage the competition, arrange for its transport to and safe storage at the venue, arrange to have it set-up, maintained, and dismantled in the course of the competition, and set up an inventory system to ensure its safe and proper return.
5. It is impossible to run a sizeable competition on one's own. Candidates must be able to effectively recruit and organise sufficient numbers of volunteers, and to train and supervise them during the running of the competition.
6. Candidates must be able to set up an efficient Directoire Technique to run the competition and supervise its work in: recruiting and managing Presidents-de-Jury, scheduling events, composing and seeding pools and tableaux, re-seeding from one round to the next, and hearing appeals from fencers.

Level IV - Competition

7. Candidates must obtain an up-to-date copy of the Regulations for Competitions and become familiar with the provisions of Part V (Art. 501-591) and Part VI (Art. 601-667) dealing with the running of competitions.

8. Candidates must be able to setup and operate an accurate and efficient accounting system, including the following elements: preliminary budget, petty cash accounting system, collection and secure handling of entry receipts and other revenues if any, accounting for cash disbursements and honoraria, settling of accounts, and production of a financial statement.

TASK 2 - DELIVERY

1. All candidates will be required to read the prepared course materials.
2. One or more "mentors", who may or may not be qualified coaches will be assigned to each candidate to assist in organising and running preliminary competitions to gain the experience necessary to run a provincial championship. These persons may be chosen by the course conductor or by the candidate, provided that the candidate's choices must be approved beforehand, and must have extensive knowledge of at least one of the areas listed for evaluation.

TASK 2 - EVALUATION

Candidates must organise, run, and report on a provincial championship level competition (see "Task 2", above). Two examiners will attend the competition, and will evaluate it (subjectively), scoring each of the following areas on a scale of 1 to 10. Areas 2 and 7 will be worth 20% of the final grade, and each other area will be worth 10%. The grades from the examiners will be averaged to determine the final grade. A final score of 75% will be required to pass the evaluation.

1. Planning and Scheduling. (10%)

This will include the appropriateness of the schedule considering the anticipated entry, venue size, and numbers of pistes, apparatus, and Presidents-de-Jury available.

2. General efficiency (20%).

This will include the degree to which the competition actually followed the schedule, with additional consideration of particularly efficient or inefficient arrangements in any specific area.

3. Staffing. (10%)

This will include the recruitment and training of competent volunteer staff in all of the areas necessary to organise and run the competition. Particular emphasis will be placed on the ability to train sufficient numbers properly and effectively, and to manage effectively under pressure during the competition itself.

Level IV - Competition

4. Registrations. (10%)

This will include the effectiveness of the registration system in taking accurate information and relaying it to the Directoire Technique, effective use of entry forms, filling out of pool cards, etc.

5. Venue. (10%)

This will include the suitability of the venue, any effective modifications that have been made, and the safe and efficient use of space for competition and ancillary activities.

6. Apparatus. (10%)

This will include the efficient setting-up, maintenance, and dismantling of apparatus, inventory control, transport, and the setting-up of a repair shop.

7. Directoire Technique (20%).

This will include the candidate's ability to recruit and manage a Directoire Technique in running the competition, solving any problems that may arise, and supervising and coordinating the activities of volunteers working in all other areas of the competition.

8. Accounting (10%).

This will include the reasonableness and structure of the initial budget, and the degree to which it was adhered to in practice, on-site procedures such as the handling of cash and disbursements, the petty cash system, banking of any receipts, and the organisation and accuracy of the final financial statement.

The Canadian Fencing Federation and the examiners reserve the right to specify the time and place of the test competition. Because of the emphasis placed on the candidate's ability to select and train inexperienced staff, tests may be staged in regions where experienced personnel are not available.

I - PRELIMINARY CONSIDERATIONS

1.1 THE ORGANIZING COMMITTEE.

The first step in organizing any competition is to draft a list of the various tasks that will have to be done, when they will have to be done, and who will do them. A meeting should be held at least 3 months prior to the competition date to allow sufficient time for proper advance planning and responsibilities assigned to persons willing to take them and capable of effectively carrying them out. A number of distinct areas are listed below, but it is not necessary to have a separate individual assigned to each. Most committees function more effectively if kept fairly small in relation to the workload. It is best to separate areas that must be supervised at the same time, such as Directoire Technique and Apparatus, to ensure that the responsible person will be available within his or her area when needed.

Each individual member of the committee should be instructed to draft a complete list of the tasks in his area, times by which they must be completed, anticipated costs if any, and manpower requirements. The entire committee can then integrate these estimates into an overall schedule and budget at a subsequent meeting. Members should be encouraged to keep written records as much as possible, as these will be valuable in assessing the successes and failures of the competition and in planning subsequent ones. Each member is then responsible for recruiting and training any necessary staff within his assigned area.

It is not usually necessary for the committee to meet again prior to the competition, but the progress of each member must be monitored closely by the chairman. This is especially true where the competition is a major one, or where particular members are given responsibilities for the first time. Personnel management skills are an asset here; members must be allowed to apply creativity and initiative to their jobs, but the chairman must ensure that the proposed methods will work and that essential jobs have in fact been done by the proper deadlines. The chairman must have enough expertise to be able to review each member's plans and progress, to co-ordinate effectively between related departments, and to double-check the workmanship in a few essential areas (proof-reading entry forms, for example).

The committee should meet within two weeks after the competition for a final wrap-up and post-mortem. The work of each member should be reviewed by the whole committee, successes and failures discussed, and suggestions for improvements tabled. It is important that a written record be kept of this meeting, since it will be used to modify the original work-list into a new, improved document for use in the next competition. After a few years of working as a team, a particular committee can become very efficient, and the successive work-lists can be used to train new members and to ensure that nothing is overlooked.

A list of the major and minor areas of responsibility is as follows. It is not meant to be exhaustive, and it is possible to organise somewhat differently, depending on the personalities and expertise of the members of the organising committee. What is essential is that no task is left unaccounted for, and that all of the tasks in each area are within the capabilities of the person assigned to carry them out.

1.1.1 CHAIRMAN OF THE ORGANIZING COMMITTEE

This person must have a good general knowledge of the sport of fencing and the running of competitions, and enough expertise in each area to be able to solve problems or substitute for missing members where necessary. Where the competition is to be run each year, it is best to use a more senior or member, with newcomers being assigned to less crucial areas until they gain experience. Good interpersonal skills are also essential, since it is the chairman's job to review and criticise the work of other members. If possible, the chairman should avoid taking on other areas of responsibility that would require his attention during the actual running of the competition.

1.1.2 REGISTRATIONS

This person recruits and trains the staff who will send out registration forms, take registrations at the door, collect and account for entry fees, and compile the necessary information on the competitors for use by the Directoire Technique in seeding pools. He or she will also prepare the entry form and have it printed prior to the competition. Some of the staff who take registrations can be reassigned to the Directoire as the competition progresses, but at least one experienced person must keep working on registrations, particularly in a multi-event competition.

1.1.3 APPARATUS

This person is responsible for obtaining sufficient scoring apparatus, pistes, ancillary equipment such as extension cables, weights, gauges and mask testers, etc., and for all aspects of their use during the competition. He or she must recruit and train several technicians and supervise their work during the competition, supervise the setting-up and dismantling of the competition, set up and operate a repair shop, and be responsible for correcting technical faults before they can delay or disrupt the competition. The chief technician should not have any other areas of responsibility that would require his or her attention during the running of the competition, or immediately before or after it.

1.1.4 DIRECTOIRE TECHNIQUE

This person recruits and trains sufficient staff to keep score, compile results and reseed competitors between rounds. He or she generally runs the competition, allocates Presidents-de-Jury and pistes, and chairs the jury-d' appel if one is required. Prior to the competition, he is responsible for setting the schedule of events, recruiting sufficient competent Presidents-de-Jury, obtaining any necessary sanctions, and obtaining pool sheets, seeding cards, blank tableaux, and clipboards, pencils and erasers. He or she should also locate and set up a clean, quiet, well-lit workplace for seeding and re-seeding. He or she should not have any additional areas of responsibility during the competition.

1.1.5 TREASURER / ACCOUNTANT

This person is responsible for the security of all receipts as they come in, generally accounting for money and disbursements, paying any non-volunteer staff, pettycash accounting, banking, and eventually, the preparation of a final account and financial statement. The qualifications and aptitudes for such a position are obvious. This person must not have any responsibilities that distract him from security during the competition, but could assume other duties that do not interfere, such as taking registrations.

1.1.6 VENUE

This is a relatively minor assignment, which is mostly completed when the competition starts. This person must locate a suitable venue at an affordable price, checking floor area and surface, illumination, electrical outlets, and the availability of ancillary facilities such as shop areas, a workplace for the Directoire, change rooms and showers. He or she drafts a floor plan in co-operation with the chief technician. He or she also is responsible for liaison with any venue staff, such as managers or custodians, and may arrange for the use of refreshment areas, garbage disposal facilities or other permanent venue facilities. Since most of these duties do not overlap with other areas during the competition, it is possible to assign them to one of the other members of the committee. Often the person in charge of apparatus also arranges the venue.

1.1.7 FUNDRAISING

If the club or hosting organisation has a permanent fundraiser, this assignment can be a part of his regular duties. Often the same person can also be made responsible for Public Relations (below), since there is a great deal of overlapping responsibility.

The fundraiser is responsible for soliciting corporate or private sponsorships, endorsements, prize donations, and any other forms of external financing for the competition. If funding is to be provided by any government agency, the provincial association or the CFA, this person should act as the liaison with those organisations. He or she must be knowledgeable about the competition, the hosting organisation, and the sport in general so as to be able to answer questions from potential sponsors, and to generally "sell" the competition. He must work closely with the Treasurer and the PR person to market the competition effectively.

He or she is also responsible for on-site fundraising schemes such as the sale of Tshirts or other items.

1.1.8 PUBLIC RELATIONS

This person should be fairly knowledgeable about the history of the competition and host organisation, and be able to communicate effectively verbally and in writing. Prior to the competition, he or she prepares a series of press/media releases containing as much information as possible and circulates them to the local press and broadcast media. During the competition, the PR person or a substitute must be available at all times to assist reporters in any way necessary. This may include providing information about the competition or any of the competitors, and being interviewed or arranging interviews with other organizers or competitors. If possible, all liaison with the media should be through this person.

1.2. THE SCHEDULE OF EVENTS

A reasonable schedule must be prepared in the early stages of planning, since a final version must be printed as a part of the entry form. Begin by listing the events to be staged and the number of entries expected for each. It can be very difficult to accurately estimate this, so a generous allowance should be included, especially the first time a competition is held. If team events are to be held, these must be listed separately. Also obtain the number of pistes and Presidents that will be available, and the hours during which the venue will be available.

In general, it is best to begin the largest event first, and then add one or more smaller ones using the left over pistes later in the day, as fencers are eliminated from the main event. The time lapse between the start of the first event and the second will depend on the number of rounds to be fenced and the number of pistes available. A round of pools of 5 or 6 fencers takes 1 1/2 to 2 hours (assuming bouts of 5 hits), so 2 hours per round should be allowed. If the entry is very large (or the number of pistes small), it may be necessary to fence the first round in two flights (allow 3 1/2 hours). Often it will be necessary to finish the second round of the first event before the second one can begin (to clear enough pistes), and this will always be necessary if no fencers are eliminated during the first round.

If the second event is also fairly large, it will usually be necessary to discontinue the first event while the first, and possibly the second round of the second event is fenced, since it will consume most or all of the pistes. The objective should be to reduce both events to the point where they can be run simultaneously on the available pistes. It must also be borne in mind that no more than 50% of the competitors can be eliminated in each successive round²⁰.

Most individual competitions will consist of one or more rounds of pools to reduce the number of competitors to 64, 32, or 16, depending on numbers, followed by a direct elimination format to decide the eventual winner. Each round of direct elimination (including repechage) consumes 1 1/2 to 2 hours, and a number of pistes equal to half the number of bouts to be fenced. A table of 32 fencers, for example, involves 16 bouts (initially), and would occupy 8 pistes for about 1 1/2 hours, including repechage.

20. See Regulations for Competitions, Articles 522, and 539.

Team events are usually fenced as a number of pools of 4 teams to a final direct elimination table of 4 or 8 teams. Each team match is composed of a maximum of 16 bouts (an individual pool of 6 fencers is 15 bouts), with the average time required between 1 and 1 1/2 hours. If pistes are available, 2 should be assigned to each pool of 4 teams.

1.3. THE BUDGET

A budget for the competition should be prepared in the very early stages of planning, particularly if it is the first competition staged by a club or committee. Starting a new annual competition is like starting a business - it will frequently lose money in the early stages, and then begin to show a profit in later years, as its reputation and entry grow. If accurate financial records are kept, they can be compared with the figures predicted in the budget, which will provide valuable guidance for planning subsequent competitions.

Essentially, a budget consists of two lists, summarizing the potential revenues from a project and the potential costs involved, and some predictions as to whether money will be lost or made by the project. Obviously, if the possibility of loss is predicted, the organisation must either be prepared to make up the deficit from other sources, or to find ways to alter the existing predictions by increasing revenues (raise entry fees) or decreasing costs.

Thus the budget is a valuable tool in planning the competition. It allows the organizers to weigh the various factors together before committing themselves to specific figures. A typical decision, for example, might involve a choice between 3 variables: increase revenues by raising entry fees (which may decrease the number of entries), increase revenues by increasing the number of entries (decrease fees and spend more on promotion), or decrease costs by renting a smaller gymnasium. This process will lead into many secondary decisions, as various solutions are suggested: for example, if the size of the competition is to be increased, can sufficient apparatus and Presidents de Jury be obtained, and what will the increased cost be?

A major problem with budgeting, especially among those with little experience in staging competitions, is obtaining accurate figures on which to base the necessary decisions. Most budget figures will be estimates, and these are difficult to make without personal experience in the area involved. Accuracy can be improved by consulting persons in other clubs or organisations who have the necessary experience, but beware of geographical or sport-specific factors that would make adjustments necessary before the figures accurately apply to specific competitions. It must also be borne in mind that the budget relies on estimates, and will never be completely accurate. The accuracy and reliability of the final decisions based on the budget will be no more reliable than the data used as the basis for the budget in the first place. Avoid relying too heavily on the budget decisions, and avoid the tendency to allow wishful thinking to affect either the estimating or decision-making process. Estimates and decisions should be on the conservative side (underestimate revenues, overestimate costs), particularly if the planners have little experience, or the sponsoring organisation cannot afford to lose money.

The following is a list of revenues and costs typically encountered in planning a fencing competition.

1.3.1. REVENUE SOURCES

Entry fees. Total revenues will depend on the number of fencers and the amount set as the entry fee. Allowances must be made for reduced fees for junior fencers, multiple entries, and persons whose fees are waived as payment for services rendered, if any.

Fundraising or sponsorship revenues, if any. These would include subsidies from private or public sources, assistance from the provincial association or the CFF, and donations of goods or services, such as gymnasium rentals or prizes.

Miscellaneous revenues. Any funds raised from other projects related to the competition, such as T-shirt sales. The costs incurred as part of such a project must be taken into account, either by subtracting them from the revenue predicted (i.e.: estimate of net revenue), or including them as tournament expenses elsewhere in the budget.

1.3.2. COSTS

Venue costs, including rentals of gym space and ancillary facilities such as change rooms, an office for the Directoire Technique, etc. Determine all costs associated with each of the venues under consideration before calculating this amount. Often some costs, such as cleaning fees, and wages for staff (allow for overtime!) are not apparent at first.

Apparatus costs, including rental of equipment, if any, and maintenance, repair, and transportation or shipping costs. The last are particularly significant if bronze pistes are to be shipped any distance. If pistes are to be used in any numbers, allowance should also be made for the cost of duct tape for stretching them (usually about one 50m roll per piste).

Staff costs, including honoraria for Presidents, technicians, minor officials, etc., and any accommodation costs, if these are to be paid.

Purchase of prizes or trophies for winners.

Miscellaneous costs. These are difficult to estimate, so the estimate should make relatively large allowances for error. Include such things as refreshments or food for officials, stopwatches, printing costs (entry forms, pool sheets and tableaux), postage, telephone calls and stationery.

1.4. THE ENTRY FORM

Once the preliminary decisions have been made affecting finances and scheduling, the entry form can be drafted. It should be proofread before printing by as many people on the committee as possible, since a mistake, especially in the schedule of events, can result in major problems.

The form should clearly identify the name and date(s) of the competition and the sponsoring organisation(s), the location and address of the venue, entry fees, and must include a detailed list of events and scheduled start times. It should state that the competition is sanctioned by the appropriate authorities, and that the F.I.E. rules apply, or list any exceptions to those rules that will be made. It should also include any special regulations imposed by the organizers dealing with pre-registration requirements, latecomers, the format of the competition (if known in advance), etc. The entry form should also state whether the competition will count towards CFF national rankings or not. As a courtesy to the fencers, it is also a good idea to include an accurate map locating the venue. This also benefits the competition by reducing delays caused by latecomers.

The entry form itself must be easily filled out, and easily read by the registration staff when received. Allow ample space for fencers to furnish the necessary information. Fencers must be asked to provide their full name, club affiliation (if any), national affiliation, ranking or classifications (if any), and the event(s) to be entered. If a mailing list of past entries is kept, fencers should also be asked for their home address. If fencers are asked to pre-register by telephone or mail, then the necessary addresses and telephone numbers must be included, preferably in more than one place.

The entry form should conclude with a statement that the competition and all parties connected with it are not responsible for any injuries or losses of any kind suffered by the fencer during the course of the competition. This statement, known to lawyers as an "exculpatory clause", may protect the organizers from legal liability if they are sued as a result of a mishap at the competition. It should be worded in ordinary English (or French)²¹, and state clearly that the fencer, as a condition of being permitted to enter the tournament and allowed to fence, acknowledges that he does so at his own risk. It must be signed by the fencer, or if he is a minor (less than 18 years of age in Ontario), a parent or legal guardian. The use of such a clause does not completely protect the organizers, however, and reasonable precautions to prevent accidents or other mishaps should still be employed.

21. Note that a clause drafted in only one of Canada's official languages might not be valid against the claim of a person who did not speak that language if there was a reasonable expectation on the part of the organisers that both Francophone and Anglophone competitors would attend. Even if the form itself is unilingual, the exculpatory clause should probably be drafted in both official languages. Forms for international competitions should be drafted in French. It is customary to send a copy with a covering letter to each national federation invited to attend.

1.5. THE SANCTION

The Canadian Fencing Federation requires that all competitions must be sanctioned either by it or by a provincial affiliate association, and disciplinary action may be taken against anyone who stages or competes in an unsanctioned competition.²²

This serves to keep the governing bodies informed as to what competitions are being staged, and permits them to exercise some control or management. In Ontario, for example, a sanction may be refused because a particular competition conflicts with another, or because the organizers are not members of the Ontario Fencing Association. In events funded by the OFA (provincial championships), sanctions may also be refused on the basis that the planning for the competition is not sound (insufficient funds or an unsuitable venue, for example). As a general rule, the sanction must be obtained from the Treasurer or Secretary of the provincial affiliate of the CFF, and organizers must be able to demonstrate that the project is viable (Ontario requires that a copy of the entry form be submitted with the request).

22. See Rules and Regulations, Canadian Fencing Federation Constitution and By-Laws, Articles 1002 (Jurisdiction of provincial affiliate over sanctions), 1101 (Sanctioned event must prohibit non-members from fencing), and 1209 (Automatic suspension of any member knowingly fencing in unsanctioned competition).

1.6. THE VENUE

1.6.1 RENTAL OF THE VENUE

Most of the functions of the person responsible for the venue are discharged shortly before or during the competition. As a preliminary matter, however, he or she must ensure that the venue is reserved and that a firm rental contract is signed as far in advance as possible. This contract must specify the times for which the venue is in use, the areas to be used, and the rental costs, since all of these items are essential to the preliminary planning in other areas.

The venue should be reserved for the evening before the competition to permit sufficient time to set up apparatus and other areas for immediate use on the first day to reduce delays in getting started. Depending on the numbers and experience of the available manpower, a four-hour session will usually suffice to set up a large competition (10 pistes or more). It must also be reserved for the same length of time after the fencing is scheduled to end for dismantling and clean-up.

To protect the competition from unforeseen costs for labour, such as overtime or cleanup costs, these should also be specified. The overtime provision is particularly important, since any large competition, no matter how well planned or run, will run past its allotted schedule from time to time.

1.6.2 CHOOSING THE VENUE

Choosing a venue is one of the most important preliminary decisions to face the organising committee. The gymnasium itself must be adequate in size, floor space and surface quality, lighting, etc., but other considerations, such as changing facilities, parking, access to public transport and accommodations are also critical.

Begin by examining the competition schedule and number of entries anticipated to estimate the number of pistes that will be required. Allowing at least two extra pistes will provide a margin for error or unforeseen problems such as equipment breakdowns. This should give a minimum adequate size, so that only suitable venues need be inspected. A committee member should then visit each potential venue and make notes for comparison. If possible, obtain a copy of the architect's floor plan of the gymnasium area (maintenance staff usually have these). There is usually a separate sheet for each level of the building, so it may be necessary to have more than one if usable facilities are located at levels other than that of the gym itself. Inspect the actual gymnasium and compare it with the floor-plan. It is particularly important to note the addition of equipment or modifications that have been added since the plans were updated, since these may reduce the available space, and often do not appear on the plan itself. Most professionally -drawn floor plans also contain the dates at which the drawing was made and revised, the scale, and other useful information.

The following information should be carefully noted:

1. Floor space. Each piste will take up a space approximately 4×19 metres, including space for presidents and apparatus. More space will be required if raised pistes, bungee-cord apparatus, or overhead display units are to be used. More space should also be allocated for pistes to be used for non-electric sabre. Check for obstructions, such as pillars, floor defects or hardware, or fire exits, that would make some floor space unusable. Extra space should also be allowed to permit storage of fencing bags, spectators, and so forth.
2. Floor surface. This must be flat, level, and smooth, especially if metallic pistes are to be used, since these may be damaged by uneven surfaces. Hard floors (terrazzo, concrete, tile etc.) should be avoided if possible, since they increase the chances of leg injuries for competitors. Ideally the surface should be a layer of wood supported by "spring" layer between it and the concrete below (this is standard in modern gymnasium construction). Rubberized floors (3/4" of rubber on concrete) are also suitable.

Check for floor-mounted hardware. It must be flush with the surrounding area to avoid injuries or damage to pistes, and should also be insulated from metallic pistes laid over top of it. Metal hardware is often electrically grounded to the structure of the building itself, and may carry enough voltage to confuse or even damage older scoring apparatus.

If metallic pistes are to be fastened down or stretched with adhesive tape, take a sample along to check its adhesion to the floor. If it does not stick well, clean the floor and try again. Check that it does not leave any residue or lift painted marks off the surface when removed.

3. Illumination Fencing requires a higher level of light than many other gym sports such as basketball or volleyball. If the venue is for an F.I.E.-sanctioned competition, the illumination standard set down by it must be complied with.

For less-sophisticated competitions it might be wise to try fencing a few bouts there, or to use a photographic light-meter to compare light levels with those of a salle or gymnasium where light levels are known to be adequate. If the gym contains skylights or windows, it is important to check levels after dark when they will be lowest. Windows facing east or west, and other directional light sources should also be noted, since these may have to be masked or disconnected to prevent blinding competitors during the fencing.

4. Electrical power. Scoring apparatus draws very little electrical power, so the overall wattage available will not usually be a problem, even if overhead displays are to be used on all pistes. Location, condition, and distribution of outlets is important however, because this will determine the amount and location of power cable required to run to each piste. Outlets must provide a firm grip and constant power feed into a standard 3-pin plug.

The locations of fuse or circuit-breaker panels should be noted on the floor plan. Check whether other equipment is also drawing power from the same circuits, as the use of overhead apparatus may overload a heavily-loaded circuit and blow fuses or trip breakers. Voltage drops from other equipment, especially large heating or airconditioning motors may also affect scoring apparatus.

If the competition is a major one the electrical requirements for television broadcasting may also become a factor, and it may be necessary to note the location and capacity of the building's electrical supply. Major broadcast facilities can draw as much as 1200 amperes at 220v, mostly used for high-intensity lighting. If this much is required however, they will normally bring in their own generators or arrange for connection directly to the local utility grid.

5. Entrances and exits. These should be checked against the floor plan and any variations noted. Determine which will be used, and how heavily, during actual competition, as it is generally wise to avoid laying pistes near them. Major entrances will be a factor for spectators (to outside, food facilities, washrooms etc.), competitors (armouries, change rooms etc.), and staff (armouries, directoire technique etc.).

Note the locations of fire exits, as these must not be obstructed by pistes or stored equipment. If large numbers of spectators are anticipated, the exit requirements should be checked with local fire authorities.

6. Ancillary areas These include changing facilities for competitors and officials, lobbies, food services and washrooms for general use, media facilities, the directoire technique, and shop or armoury facilities. They should be noted on the floor plan by room number or other identifying information.

Their location in relation to the gymnasium is important for laying out exits, piste plans etc. The characteristics of some may also be important. The directoire technique must be secure, and there must be adequate power in the armoury, for example.

7. Other facilities. Many other facilities normally associated with the venue are desirable or indispensable to the efficient running of a competition. these will vary considerably according to the specific circumstances of the competition. If the gymnasium is very large a sound system will be needed. Most facilities will have one already installed, but if not, one must be rented. If media coverage is likely to be heavy, ready access to telecommunications equipment, telephones, or even a complete media centre may be required. If equipment must be struck during the competition, storage areas and staff will be required. If the competition is to be held at more than one venue, transportation and a telephone or intercom link may be needed. It would be impossible to draft a comprehensive checklist of other facilities, but the person in charge of locating a venue should discuss any special needs with each of the other members of the organising committee so that a list of facilities needed for each specific competition can be drawn up.

1.6.3. PREPARING A FLOOR PLAN (see Fig. 18, page 77)

Preparing a floor-plan of the proposed venue accomplishes two purposes: it will highlight potential problems on paper while it is still possible to avoid or rectify them easily, and it will serve as an accurate reference for those setting up and running the competition. Before beginning, basic information must be determined in concert with other members of the organising committee. It may be possible to draw rough plans of more than one possible venue to assist in choosing between them, but obviously, the venue must be chosen before a final plan can be drawn. It is also necessary to finalise the number of pistes and a basic schedule of events.

Begin by taking a copy of the architect's floor-plan, if one is available. If not, it is necessary to go to the venue and produce a rough sketch of it, noting every detail, including wall locations and angles, doors (location, width, direction of opening, locks, status of fire exits, etc.), floor hardware and electrical outlets. A large clipboard, several sheets of graph paper and 50-foot tape measure are essential for this, and an assistant is also helpful. If a proper floor-plan is available, take it to the venue and verify that it is accurate (with the tape measure). Most plans have been simplified and will not contain sufficient information, so some notes will still be necessary. Locations of doors will be shown, for example, but not the direction they open or where they lead. Electrical outlets and window locations usually also must be added.

Once all of the necessary information has been gathered, a new plan should be drawn. Since much of the information contained on the architect's plan will not be relevant to a fencing competition, it can be omitted. Usually the finished plan can be drawn much smaller than the original. If it is reduced to a standard photocopier format, it will be easy to make additional copies for use by other personnel. A photocopy of the empty floor-plan should be made before any pistes are drawn, so it can be saved for future competitions or used to consider alternative piste lay-outs.

1.6.3.1 Laying out pistes

Once the empty plan has been copied, possible piste arrangements can be considered. Lay an empty plan on the drafting table and beside it a small piece of showcard, bristol-board or a similar material. Determine the scale dimensions of a single piste from the floor-plan, and draw them on the cardboard. This can now be cut out and used as a template to lay the pistes out to scale of the plan. The template can be moved about to determine whether pistes will fit in a given arrangement, and then used to trace the edges of the pistes out onto the plan itself.

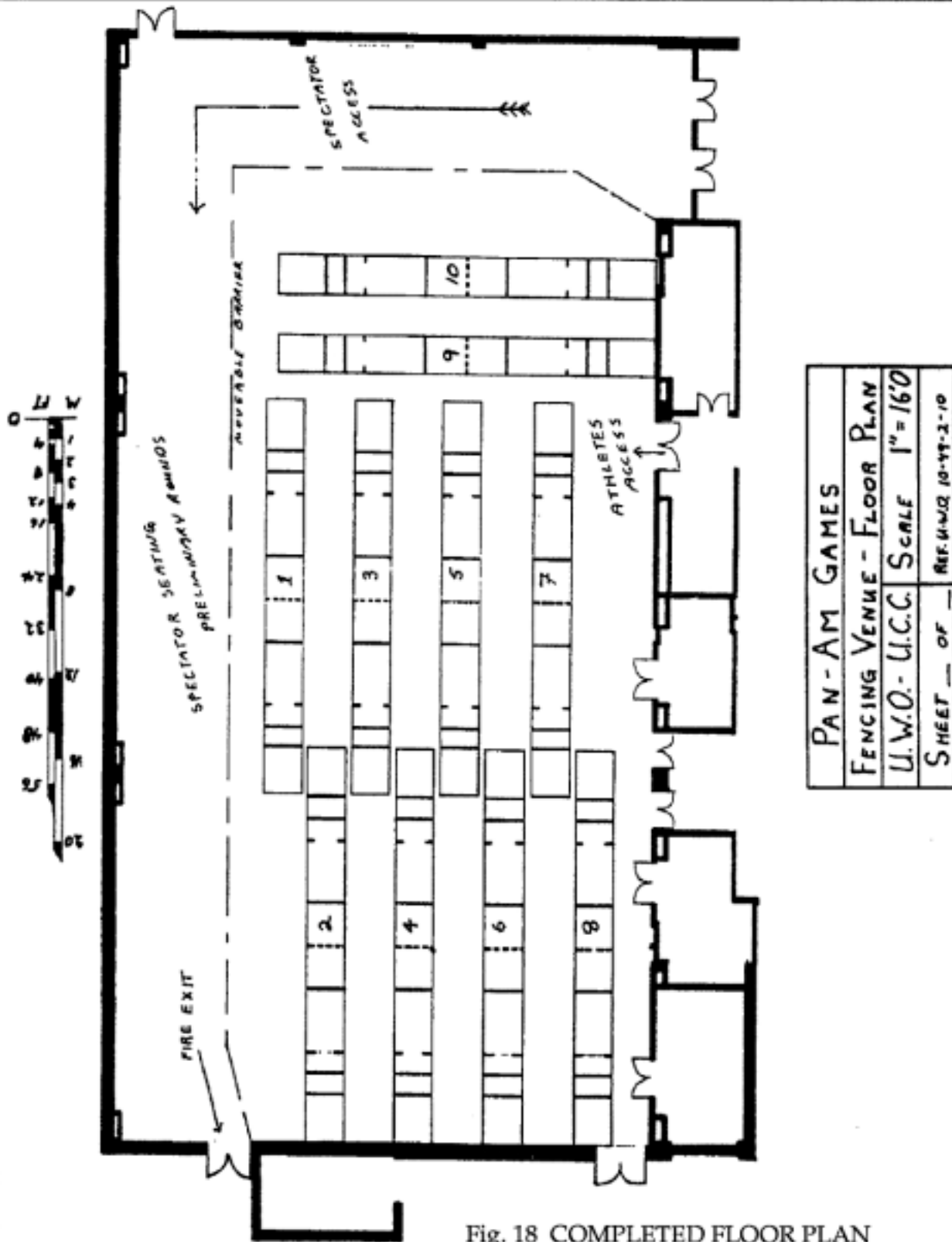

Fig. 18 COMPLETED FLOOR PLAN

Copies of this floor plan go to registrations, directoire technique, apparatus, etc. in this form. Other informations, such as cable locations, pool allocations etc. are added later.

The following points should be considered when laying out pistes:

1. The distances and locations of electrical power supplies.
Cables must be run around the ends of pistes, which can greatly increase the distances involved. Cable runs may be reduced by placing pistes "back-to-back" (see Fig. 18, page 77), so that two adjacent sets of apparatus may be run from the same cable feed. If more than two sets containing overhead display units are to be run from a single cable feed, the electrical capacity of the circuit and the cable itself should be checked, especially if the cable run is very long. #14 AWG cable is standard for most uses, and will safely carry 15 amperes (about 1500 W) in a fifty-foot run.
2. The locations of entrances and exits for spectators and competitors.
The floor space around these will be heavily travelled and should be kept free if possible. If not, it is preferable to use them for registration or other administrative functions rather than pistes. If a piste must be laid close to a doorway, consider whether the door can be locked and passers-by routed elsewhere. The door must have a working lock, and not be listed or marked as a fire exit if this is to be done.
3. Avoid laying pistes perpendicularly to one another if possible, as this can result in fencers fleching onto adjacent pistes during competition. If this is necessary, allow additional run-off space accordingly.
4. Allow sufficient room behind the ends of each piste to accommodate a safe run-off area and any stretching hardware that will be used. Article 15(3) of the Rules for Competitions requires a minimum of 1.5m of metallic run-off surface, but many piste manufacturers allow a full 2m. It may be necessary to unroll and measure metallic pistes to confirm actual dimensions. Normal stretch hardware usually consumes an additional 0.5m at each end. The amount of run-off required may also increase if unusual hazards to fleching fencers, such as adjacent pistes, raised piste surfaces, or hard or sharp objects (steel gymnastics apparatus, for example) exist. Consider whether such obstacles can be removed or padded. Bunge-cord apparatus requires a full metre behind the end of the piste, although about 2m is preferable. This is normally contained within the metallic run-off area, but becomes significant if short or non-metallic pistes are used.
5. Allow sufficient room between the lateral boundaries of parallel pistes.
The minimum safe distance between adjacent pistes is about 1.5m, but more space is required if apparatus or presidents will be there. Apparatus should be at least 1m from the piste, so the minimum distance becomes 1m plus the width of apparatus tables. Presidents generally require 3m, as do side-judges for sabre (this may be avoided if only every second piste is used). Reels will fit within the minimum 1.5m allowance, but bungi-cord apparatus requires a full metre per set, for a total of 2m if sets are used back-to-back on adjacent pistes. If pistes are laid "back-to-back" or interlock (Figs. 19&20, pages 79&80), the space consumed by presidents and apparatus can be minimised.

6. The location of spectators and/or media.
Pistes should not be laid out "end on" to these locations if it can be avoided. If not, consider the possibility of changing floor-plans (or even venues) between preliminary and elimination or final rounds.
7. The locations of pistes on which advanced and final rounds are to be held.
These should be identified early and their locations clearly marked on the floorplan. They should be ideally located with respect to spectators and the media (see above), and should permit extra space for presidents, side-judges, etc. Set-up personnel need the locations to set up special scoring apparatus, and the directoire technique must ensure that they are free during the appropriate times in the schedule.

FIG. 19 COMMON PISTE ARRANGEMENTS - "INTERLOCKING" METHOD

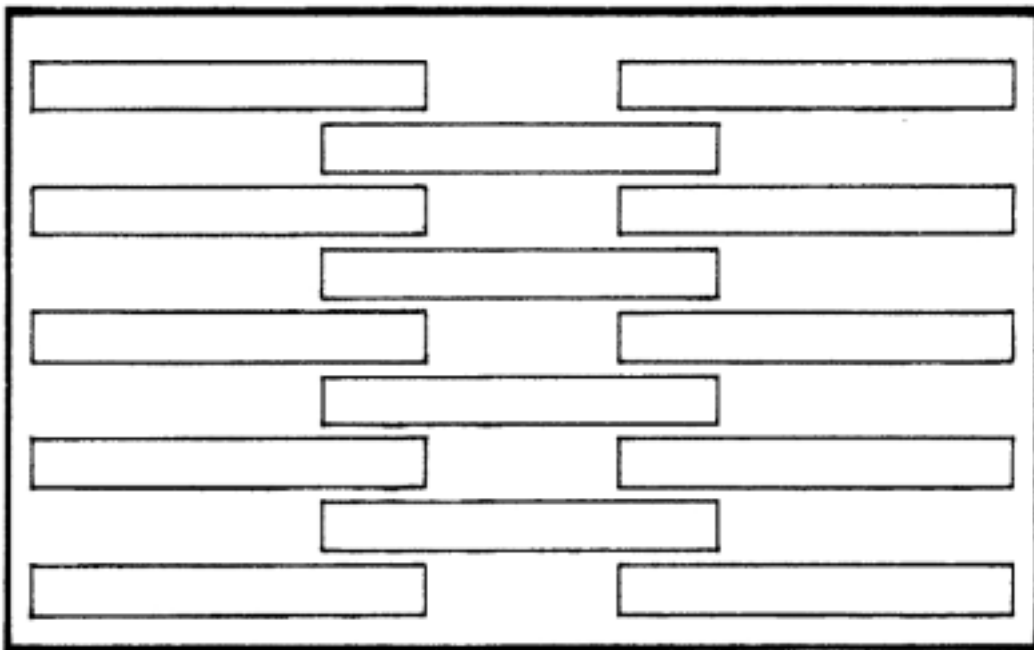

This arrangement makes a maximum use of floor space, but is inconvenient for presidents as they cannot move the entire length of the piste. It is not recommended for sabre competition because of the run-off hazard and crowding of side-judges.

FIG. 20 COMMON PISTE ARRANGEMENT - "BACK TO BACK" METHOD

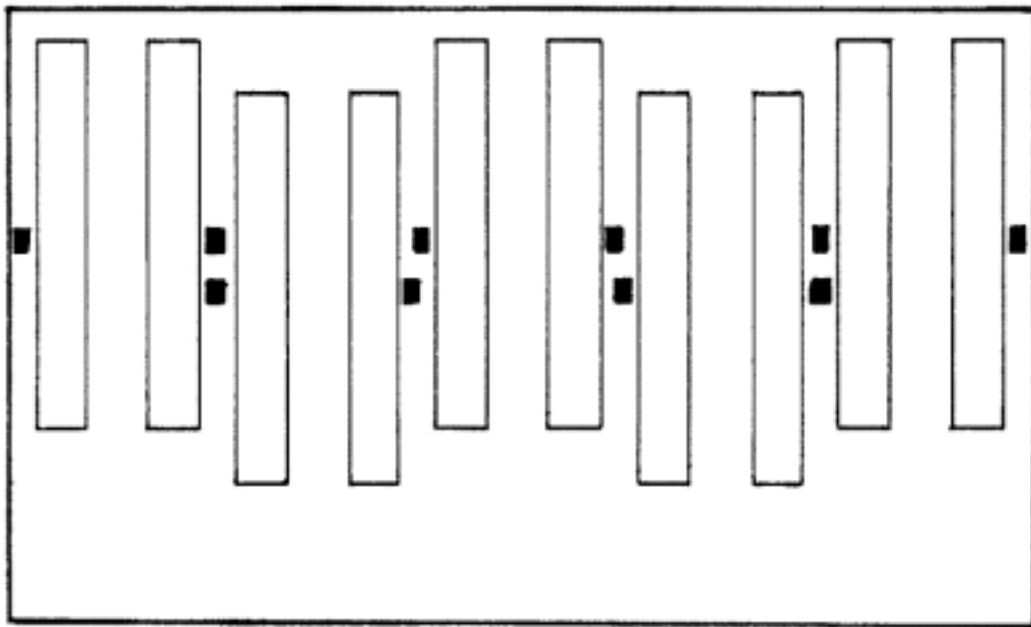

Pistes are staggered, with extra space allowed between pistes where presidents must walk, and less space where apparatus is located. Note the off-setting of back to back pistes so that centres do not line up.

1.6.3.2. Preparing drawings (Fig. 18, page 77)

Once the basic arrangement of pistes is determined, it should be laid out carefully onto a clean copy of the empty floor-plan. Show the outline of each piste, the locations of centre, en garde, and warning lines, and the outline of any apparatus tables. Assign numbers to the pistes and identify those that will be used for the finals. Special notes, such as "practice only", or "do not use for sabre" should be added if space permits. If not, prepare a separate sheet listing pistes by number, including any special notes for each and leaving room for use by the directoire technique to draw up schedule for each piste.

Copies of this drawing should be circulated to all members of the committee, since they will be used for allocating apparatus (technician), assisting the media (public relations), allocating pools officials (directoire) and so forth.

Level IV - Competition

The copy kept by the technician can then have the locations of electrical outlets, cable routes, bungee cord apparatus etc. marked on it. This is then used to determine how much apparatus and especially cable, will be required. If the "back to back" method is used, less cable will be required, but most of it must be equipped with duplex receptacles at the female end, so this should be noted. If any pistes are only to be used for non-electric sabre, they should be so marked so that apparatus is not set up there by mistake.

Since the copy kept by the technician will also be used by set-up crews, it must also have dimensions marked out on it so that it can be transferred to the gymnasium floor quickly and easily. It is much less trouble to determine the width of pistes and the spacing between them on paper than during the confusion of actual set-up. Distances between walls and pistes, and between adjacent pistes (especially if the spacing is not uniform) should all be marked. A fair amount of redundancy is also desirable, since this will often expose measuring errors at the drawing and set-up stage.

1.7. OFFICIALS

Initial arrangements with Presidents de jury and other outside personnel can be made by telephone, but it is good policy to send each a letter confirming the competition's offer of employment and listing terms and conditions well prior to the competition. Each letter should specify when and where the individual's services are needed, what services are required, what honorarium will be paid, if any, and any other arrangements, such as meals, accommodations or transport. Even if the sums involved are not large, outside personnel should be treated as professionals as much as possible.

A firm commitment should be sought from each prospective President as far in advance as possible to allow for budgeting and other planning considerations. Each President should be provided with as much advance information as possible, including scheduling, locations, accommodations and so forth, and given a telephone number to call should he or she be unable to attend at the last minute. In addition to honoraria, Presidents may be offered free accommodation, mileage allowances, or, if they also compete, the refunding of entry fees. Small considerations such as free T-shirts or posters can generate goodwill out of all proportion to their actual cost to the competition.

During the running of the competition, it should be the responsibility of the Directoire Technique to provide light refreshments such as coffee, and possibly even full meals if the schedule is heavy and proper meal breaks are not practical, or if food services are not easily accessible to the venue. Most presidents are not motivated by the money (if any) they are paid, but by involvement in the sport and loyalty to the competition or its organizers, which makes attention to such details extremely important. Presidents who have been ill-treated are unlikely to make themselves available in the future. Organizers should ensure that they are paid promptly, and if possible in cash at the competition, provided that receipts can be obtained (see "accounting", below).

1.7.1. NUMBER OF OFFICIALS

The number of Presidents and other officials required will be fixed by the schedule of events combined with the total numbers of competitors expected in each event. The number of pistes fixes a maximum number of Presidents that can be required at any given time. The actual number working may be less. This number should then be adjusted according to the following factors.

1.7.1.1. Self-presiding by competitors

This should only be permitted during the preliminary rounds, and avoided entirely, if resources and available presidents permit. Usually the higher-seeded fencers in each pool are capable of presiding, although full-time presidents may have to be assigned to some pools. "Floating" Presidents can then be used to preside when these fencers fence one another, as these are usually the most difficult bouts of the pool and should not be left to novice fencers if it can be avoided.

In epee, competitors can be used into the advanced rounds, and many will make themselves available after having been eliminated. It may be desirable to hold officials in reserve longer in this situation to minimise fatigue when the eliminations and finals are reached.

1.7.1.2. Fatigue

Most Presidents cannot work more than two successive rounds without fatigue affecting their work, especially if pools are large (6 or 7) or the fencing is difficult. If the schedule does not include meal breaks for fencers, then extra officials must be rotated into the presiding schedule to allow those working to take time off to eat or relax. This is especially true during the early rounds where two events are fenced together such that a round of one event has been re-seeded and is ready to recommence as soon as the corresponding round of the other event is finished. Organisers will generally want to call pools of the second event as soon as pistes become available, but Presidents should not be asked to work without breaks if it can be avoided.

It is also necessary to bear in mind that the most difficult presiding work generally comes at the end of the day, during the final matches, and that those who preside them must be relatively fresh. Presidents for the finals should be given enough work during the elimination rounds that they are "warmed up" and ready to preside the finals, but not so much that fatigue affects the quality of their work.

1.7.1.3. Early departure

Since many officials will have travelled to the competition from out of town, they will often wish to leave before the final rounds are complete, especially if the competition runs into the evening before a working day. It is necessary to ensure that other competent officials are available as replacements for this period. It is a good idea to determine who must leave early, and when, at the outset. These officials can then be given the bulk of the work in the intermediate stages of the competition, saving those who can stay for the final rounds.

1.7.2. COMPETENCE

Lists of licensed officials are available from the CFF office and are published at regular intervals. Credentials may be verified if necessary by contacting provincial/state or national Federation offices, or in the case of international competitions, the FIE office in Paris. The FIE is the issuing authority for all "A" and "B" and some "C" class licenses. In Canada, the CFF issues national licenses, and the provincial associations may issue other classes below that.

FIE - licensed officials are mandatory for all FIE - sanctioned ("A-grade") events, and organisations staging such events should contact the FIE to determine minimum requirements. The current rules provide that any national federation sending more than a certain number of competitors to a competition must also provide an official, who must be licensed.

A President whose competence is not known (whether licensed or not) should be employed briefly during preliminary rounds so that it can be assessed. This will also help them to "warm up" for later rounds. The competence (or lack thereof) of officials will reflect on the credibility of the competition, so the Directoire Technique has an active interest in ascertaining it before the advanced rounds are reached. If the competition is staged in later years, those who run the Directoire will come to know who is competent and can be relied on.

Complaints and challenges to competence from fencers or coaches may be expected frequently, and are occasionally justified. They must be handled delicately and sensitively, with respect for the competitors and the president alike. The Directoire must reserve for itself the right to remove a President at any time without giving reasons, but this power should only be used in the most extreme circumstances, as a last resort. The purpose is to provide the competitors with the calibre of presiding that they have a right to expect; removal should not be used to placate irate fencers or coaches. Removal or reassignment between rounds is preferable. No official should ever be asked to preside beyond the level at which he or she feels confident and competent.

1.7.3. MINOR OFFICIALS

Where possible, non-competing club members and other volunteers should be recruited as scorekeepers, timekeepers, and so forth. This provides the competition with badly needed junior officials, and is also a good way of getting beginners involved in the larger world of fencing. A background in this area provides them with a primer in the etiquette and rituals of competition, which will make it easier for them to adjust when their turn comes to start.

Personnel problems with volunteers should also be handled as delicately as possible, bearing in mind that these individuals are not professionally competent, and are not being paid for their work. Volunteers working in a given department, such as Registrations, should be under the supervision of that committee member alone so as to avoid confusion and conflicting duties. As with Presidents, small considerations such as T-shirts will generate goodwill for the competition out of all proportion to their cost.

1.8. AWARDS

A wide variety of awards may be chosen, limited only by the nature of the competition and the imaginations of its organizers. They may be medals or trophies, or items of merchandise donated by sponsors. If the competition is a regional or national championship, a certain type of design of award may be required by the governing body.

If trophies or plaques are to be used, a detailed order specifying each type of award and the quantity required should be drawn up. Delivery should be ordered at least two weeks prior to the competition to permit errors to be rectified in time. If the competition is to be re-staged annually, a Polaroid photo of the various types of awards can be submitted with future orders to ensure uniformity. A photocopy of the order form will also simplify the task of re-ordering in future years.

The total number of awards will be the number of events multiplied by the number of places to be awarded in each. Thus five events would require 15 awards, if the top three places are to be awarded. This will usually be broken down into five each of first, second, and third-place awards. If team competition is to be held, the numbers must be multiplied further by the number of competitors allowed per team. This will require an early decision as to the make-up of teams, and whether coaches or alternates are to be given awards as well. It is wise to have at least two members of the committee review the order, since a minor mistake in arithmetic can have embarrassing results.

II. RUNNING THE COMPETITION

2.1. SETTING THE COMPETITION

2.1.1 DELIVERY AND INVENTORY OF SCORING APPARATUS

Most organizing committees will not have sufficient scoring apparatus at their disposal to stage a large competition without outside assistance. The technical staff must therefore arrange for the loan or rental of sufficient scoring apparatus well in advance of the set up date, and have it delivered in sufficient time to permit any necessary maintenance to be carried out.

The credibility of the organizing committee with other clubs will depend on whether this equipment is returned promptly and in good condition, which makes the task of inventory and maintenance a very important one. A single, specific technician should be assigned the task of clearly marking borrowed equipment as it arrives at the venue. Since this will often be happening while the competition is actually being set up or in progress, this person should not be responsible for anything else during this period. It is important that one and only one individual be responsible for this job to avoid confusion later on. That individual must ensure that other well meaning persons on the set up crew do not unload cases and set up unmarked equipment. Note that the sample inventory list (Fig. 21) requires the person recording the inventory to initial each entry as it is recorded.



ONTARIO FENCING ASSOCIATION Page —

1986 Nationals ~ Equipment List

Box No	RECEIVED FROM	CONTENTS (LIST)	INITIALS

FIG. 21 SAMPLE EQUIPMENT INVENTORY SHEET

Each equipment bag or case should be assigned a number as it arrives, and it and every piece of apparatus it contains should be clearly marked with that number as it is unpacked. A master list is then drawn up indexing the case numbers to the club or individual who loaned them and a complete list of the equipment each case contained (See Fig. 21, page 86). The numbering tags need not be elaborate or expensive, but must be durable and unique enough that they cannot be mistaken for any other markings on the equipment. Heavy masking tape or adhesive-backed paper labels will usually suffice, and the numbers can be written on with a dye marker as required. Unusual colours of paper or marker will usually be enough to make the labels distinguishable.

2.1.2 LAYING AND STRETCHING PISTES (see Fig 22&23, pages 89&91)

Prior to beginning the setup, the gymnasium floor should be well swept, and if possible, mopped. This removes unnecessary dust from the scene, and will enable the tape used to anchor pistes to grip the floor better.

Once this is done, lay out the locations of pistes on the floor from the floor plan, using a tape measure and chalk, or in the "back to back" formation (Fig. 20, page 80), the rolled pistes or cases may simply be spaced out along one wall. No pistes should actually be unrolled until the entire plan has been transferred to the floor and verified by someone who is familiar with the floor plan.

The order of set up will vary somewhat according to the venue and how much assistance is available, but it is generally best to start in the centre of the floor and work outwards. If possible, split the crew into teams, arranged to take the best advantage of both experienced and inexperienced help. Thus each team would have a person with extensive experience supervising the work and doing the most difficult jobs, while less experienced members do the unskilled jobs and, hopefully, learn from their experience. Each team should be responsible for all of the operations necessary to lay and stretch each piste, and should not be working on more than two (adjacent) pistes at any one time. Pistes become vulnerable to damage once unrolled, and are not protected until they are stretched and the edges fixed down. Therefore it is preferable to have three teams each working on one or two pistes than to have 12 or 14 pistes unrolled before any are stretched and taped.

The order of operations or stretching a wire-cloth piste is as follows:

1. Lay a paper backing (newsprint will suffice) onto the floor so as to extend out to within about 15 cm of the lateral boundaries of the piste and to the warning lines at each end. This is necessary to prevent the movement of the piste during fencing from scraping finish off the floor. A bronze piste will completely strip the varnish from a wooden gym floor during a 2-day competition, especially if it is not tightly stretched and anchored.
2. Line up the rolled piste at one end of the position it will eventually take. If it is in a case, remove it. Note that pistes can be rolled out of boxes - they need not be lifted out.
3. Unroll the piste into its position, and double-check the ends against the floorplan. Borrowed pistes may not be the same length as drawn. Check the location of the centre if the offset/back to back format is to be used. Centres should be offset about 1 m each from the gymnasium centre-line.
4. If it becomes necessary to move an unrolled piste, line up the entire team (at least four persons) along one side, at about 2m intervals, and pull in unison. Anything that folds or wrinkles metallic cloth will cause damage. Make sure that the backing paper moves with the piste. This is more likely if the piste-edge is held as close to the floor as possible during the move, but it may be necessary to pull on the edge of the paper, or even re-roll the piste to get the two lined up properly again.

If there are not enough people available to accomplish this safely, do not risk damaging the piste. Roll it up, move it and unroll it again. Floorboards may be useful to indicate whether a piste is unrolling in the correct alignment or not.

**The next steps depend on the type of piste you are using.
Please refer to Figures 22 and 23 to identify which
procedure you should follow from now on**



a - If the piste is equipped with stretch hardware (Fig. 22, page 89),

- 5a. Lay out four complete sets, one at each corner. Each set consists of an anchor plate, a turnbuckle, and a bolt. These must be assembled in a specific order. Begin by opening the turnbuckle to within about 2 cm of its maximum travel. Then place it on the end of the piste, so as to measure the correct location for the anchor-plate. Do not bolt it to the piste at this time. Next tape down the anchorplate, using 2" reinforced cellophane shipping tape, if possible. Most duct tape is not strong enough to withstand the tensions from the piste for any length of time.

Lay two strips of tape so as to extend about 24" beyond the back of the anchor-plate, and about 3" in front of it. Press the back strips against the floor, and then raise the leading edge of the anchor-plate and stick the 3" strips under it. The tape actually wraps around the leading edge of the plate to keep it from slipping during use. Note that the back strips may have to be longer if adherence to the floor is a problem. Each anchor-plate, can carry up to 150 kg, if properly taped. When the plate is taped down, another strip of tape (this can be duct-tape) is laid over top of the cellophane to protect it and to keep the plate from lifting up if someone trips over it.

Note that the keel at the centre of the stretch plate must be parallel to the direction of the load. If the pull is at an angle, the load will be on one side of the tape only (Fig 22).

- 6a. Anchor the two plates at one end of the piste first, and then install the turnbuckles. These hook into the plates first, and then bolt onto the piste stretch bars. The piste end of the turnbuckle must be on top of the bar. (i.e. : so that the bar is between it and the floor), or it will not have enough clearance to turn.
- 7a. Repeat the same sequence of operations at the other end of the piste, first checking that it is lying flat and properly aligned on the floor and that there is no slack in it anywhere.
- 8a. Once all four corners are anchored, tighten the turnbuckles at one end to take up about 1 cm of slack. This is to ensure that the turnbuckle arbor is not transferring the entire load to the last two or three threads.
- 9a. Next tension the other end of the piste the same way. Only about 1 cm of slack should be taken out of each corner at a time. Thus one side is taken up about 1 cm, then each side can be taken up 2 cm (alternately) until the correct tension is reached. How much slack should be stretched out will vary with the age and condition of the piste, and there are no substitutes for experience. There should be enough strain to minimize slippage or movement at the centre of the piste so as to minimize metal fatigue.

Bear in mind, however, that properly-taped anchor points will support up to 500 kg as much as before the tape pulls loose or tears, and that the enormous mechanical advantage of the turnbuckles makes such strains easy to achieve. This can generate 1000 kg of strain on the piste: more than enough to tear it in half if it is old or fatigued. It can also uproot gymnasium floor boards or tiles.

Pistes laid out for more than a single day should be checked daily for damaged anchor points, loose bolts etc. and re-tensioned as necessary. Newer pistes must generally have tension added from time to time as the fabric stretches.

- 10a. Once the piste is properly stretched, the edges should be taped down. 2" masking-tape is sufficient for this, but some types be difficult to remove later, especially if the competition lasts several days, because the adhesive dries out. Note that the edges of the piste must not be taped down until it is properly stretched, as this will transfer the tension from the ends to the edges of the piste and the centre area will remain slack.

b - If the piste is not equipped with stretching hardware (Fig, 23)

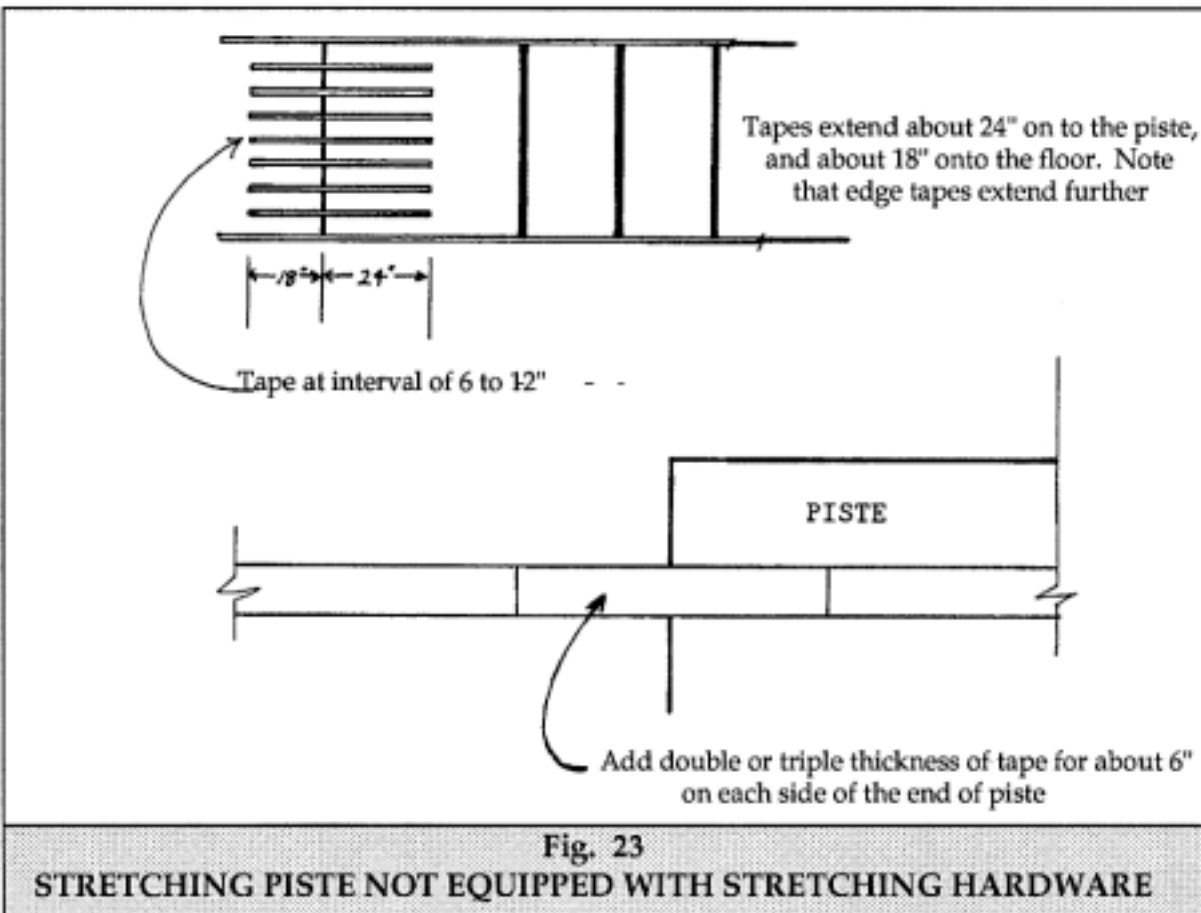

- 5b. The piste must be taped directly to the floor and stretched by hand. 8-10 strips of duct tape, extending 24" onto the piste and 24" onto the floor will usually suffice for this. If the tape will not stick to the piste mesh, it may be that it has an oil residue left from the manufacturing or shipping process. This can be removed by scrubbing with acetone or a commercial de-greaser. Since a large surface area is involved, the acetone will generate fumes that can be hazardous. This should only be done in a very well-ventilated place, and outdoors, if possible. Do not allow acetone to come into contact with gymnasium floors, as it will dissolve most varnishes, waxes, or rubber floor surfaces.
- 6b. Once one end of the piste is securely taped down, three or four persons stretch the other end, holding it at about waist-level to minimize friction with the floor, while another walks the length of it from fixed to tensioned end. He stands on the loose end while the others then tape it down as before.
- 7b. When pistes are taped directly to the floor, the maximum load on the tape is concentrated on the short length between the end of the piste and the floor, and it is here that it will tear if overloaded. If this occurs, reinforce this section with a second 12" length of tape placed on top of the first. Care should be taken that the tapes are stretched as they are laid down, and that the piste does not shift during this process. Otherwise, the tapes will not all be the same length, and tension will be concentrated on only a few, overloading and tearing them.
- 8b. Once both ends of the piste are properly fixed down, the edges are taped in the same manner as for mechanically-tensioned pistes. Since manually-tensioned pistes are not as well stretched, however, there is usually more movement in the central area, where most of the fencing takes place. This imparts more strain and wear on the edge tapes in this area, and it is generally advisable to use good quality tape or to double-thickness it between the two en garde lines.

Level IV - Competition

The allocation of these tasks among the setup teams will vary according to how many people are available and how much experience they have, but assigning specific tasks to individuals is essential to maintaining adequate quality-control. Volunteers should, never be discouraged, but neither should they be allowed to perform tasks for which they have not been trained. This is particularly true of the fastening of anchor plates, since fencers are injured and pistes badly damaged if they come loose during competition. Consider the following deployment of a team of four persons, A, B, C, and D:

A & B lay out and position underlay, while C & D position and uncrate piste.

A & B count out stretch hardware and distribute it to the four corners while C & D unroll piste and verify its position from floor plan.

A & B anchor the first point while C & D open all 4 turnbuckles. A & B will anchor all plates from this point on.

A & B anchor the second point while C & D assemble the first, and so forth until all 4 corners are complete.

While C & D assemble the fourth corner, A & B take up the slack at the other end of the piste. C & D prepare to tape down edges while A & B stretch the piste to the proper tension.

While C & D tape the edges of the piste, A & B lay out the underlay and then the next piste to be stretched.

2.1.3 SETTING UP OTHER EQUIPMENT

As pistes become fixed down and can be safely walked on, the setting up of scoring apparatus may begin. The technician responsible for inventory must supervise. This to ensure that unregistered or unmarked apparatus is not set up by mistake. Apparatus tables are set up in accordance with the floor-plan. This should be double checked, since interlocking or back to back formats are more confusing in the gymnasium than on the plan.

If bungee-cord apparatus is to be used, anchor plates must be fixed down at least 1m away from the lateral boundary of the piste, and at least 1m behind the end line (1m behind the run-off is preferable). This should be done in much the same way as for piste anchor-plates, and the same persons should be assigned to both jobs, if possible.

Cables should be laid out in straight lines and not crossed over where possible to avoid crossconnecting reels and to make problems easier to spot later on. It is not necessary to tape cables down to the floor unless they must cross a heavily travelled area, such as an entrance way. This should have been avoided when laying out the floor plan if possible. Cables should, however, be anchored to the apparatus table to prevent apparatus being pulled off if someone trips on the cable. They should be tied at the bottom of a table-leg, so that they lie flat along the floor, and tied in such a way that they can be untied again without having to disconnect them at either end first, A pair of simple overhand knots or a clove hitch, tied in a bight (i.e.: without the end) of the cable are ideal.

Power cables are run in a similar manner, but care should be taken to tie or tape cable ends together to prevent disconnection while in use. Number-cards, signs, overhead apparatus and so forth are distributed last. Make sure that tables carrying heavy overhead displays are stable enough to support them safely, and that the display units are securely attached.

Once several pistes have been completely set up, a pair of technicians should be assigned the job of testing each setup. Begin by bringing the ends of both reel cables together at the centre line and switching the apparatus on and to "epee": With a test cable, trip an epee touch on each side of the apparatus. Then switch it to "foil, thereby tripping both white lamps, since the circuits are open. Short across each foil circuit in turn and verify that the hit is cancelled as the machine resets itself.

This simple procedure will identify most problems and will take less than 5 minutes per piste. A more elaborate check may be carried out by constructing a switch-box to generate the various combinations of signal. This is usually connected to the reels using a pair of epee bodywires. If desired, the separation of epee hits and recording of double hits, and the locking-out of late hits at both epee and foil can be tested. At epee, the second touch must be locked out if it arrives more than 1/25 second after the first²³. At foil, the second or subsequent hit must not be locked out for up to two full seconds after the registration of the first²⁴.

23. See Regulations for Competition, Article 724.

24. See Regulations for Competitions, Article 713 (7).

Technicians checking the pistes should verify that:

- All apparatus is present and properly connected
- Both reels retrieve properly over entire length of piste
- Power supply to apparatus is in place, live and secured'
- Basic continuity of apparatus is correct for both foil .& epee
- Apparatus has all 8 scoring lamps in place and working
- Piste is correctly tensioned and anchored
- Piste is connected to apparatus with properly attached grounding wire
- All lines are correctly marked on piste

2.1.4 SETTING UP THE REPAIR SHOP

This should be set up early in the general setup process, as tools and repairs will be necessary as pistes and apparatus are deployed. The busiest period for repairs is immediately before and immediately after each event begins, so the shop must be ready the night before, if the first event is to start early. The person responsible for apparatus or directoire technique should ensure that sufficient stop-watches, clipboards, pencils and score-sheets are at hand as well.

2.1.5 SETTING UP THE DIRECTOIRE TECHNIQUE

Ideally this should be located in a secure room separated from the gymnasium but easily accessible to it. It should be well-lit and comfortable, and come equipped with large-surface tables to permit the laying out and sorting of pool-cards. It must have the necessary fixtures for any computer equipment that will be used, and a telephone or intercom connection with any remote venues. Chalkboards and bulletin boards are handy for posting lists of officials, floorplans with piste assignments, and so forth. For very large competitions, it should have a reception area and staff to receive competitors and coaches without allowing them access to the Directoire proper. A photocopier is not essential, but is a tremendous asset.

An adequate supply of the following items should be present:

- pens, pencils, erasers, paper clips, stapler
- direct elimination and finals tableaux (working size and large for posting)
- pool / registration cards
- National or F.I.E. ranking lists as appropriate (sorted in order of rank and alphabetically if possible)
- Several copies of the FIE Reglement pour Reglement pour les Epreuves or up to date and authoritative translations thereof.

2.2 TAKING REGISTRATIONS

2.2.1 PRE-REGISTRATIONS

Whether to emphasize pre-registrations for the competition or not is a decision that should be made early on by the entire committee. If they are to be required, this must be clearly stated on the entry form, along with a closing date and a surcharge, if late registrations are to be taken at all. If not, the form should clearly state this as well. As a rule, it is not necessary to close registrations far in advance of the competition date unless it is very large and the time will be required to compose pools or it is necessary to restrict the number of competitors somehow.

Even if pre-registration is not compulsory, some competitors will wish to register early, so it is necessary to provide a telephone number and mailing address on the entry form. If registrations are to be taken over the telephone, the person responsible for this must be wellinformed and equipped with an accurate schedule, since fencers will rely on starting times and dates provided by them. An accurate list of early registrations must be kept, and those who do pre-register should be required to sign an entry form (with its liability clause) upon arrival.

2.2.2 ON-SITE REGISTRATIONS

On-site registrations should be taken at or near an entrance to the venue. Several large tables should be set up and equipped with chairs in such a way as to permit lines of competitors to be processed in "assembly-line" fashion. A signed entry form must be collected and checked to see that it provides all of the necessary information at one stage. Another stage is devoted to verifying the competitor's national affiliation status, and for accepting funds on behalf of the appropriate federation if necessary. Another stage collects the competitor's entry fee, makes change, and records payment on a list or registration/pool card. p If pool cards are to be used, they should be filled out at each stage of the process, and a final stage is responsible for checking the cards and conveying them to the directoire technique, where they will be used to compose pools. This final verification should be completed before the competitor leaves the registration area to allow for information to be added if problems arise.

As registrations are taken and cards drawn up, a master registration list should be prepared for each event. If the competition is very large or understaffed, it may be wise to require competitors to register at different times or places for different events, to avoid registrations being mis-filed. Pool cards for different events should be on different colours of paper for the same reason. The master list should contain the following information:

Competition: Governor-General's Event: MF						
#	Name	Club	Rank	CFA#	Paid	Checked in
1.	Smith, J.	R.A.	B(25)	312	\$ 9	X
2.	Jones, B.	N /	A(?)	USD	\$15 US	X
3.	Brown, R.	ELF	(117)	213	\$12(jr)	X

2.2.3 CLOSING REGISTRATIONS

The closing time for registrations (which will have been predetermined and noted on the entryform) should be announced at least five minutes in advance. This should be done by publicaddress system in as many languages as appropriate, but in French and English in any event. A specific call should be made for any fencers who have pre-registered but have not checked in at this time as well.

Verify that the proper number of competitors are present by comparing the number of pool/ registration cards to the number of checkmarks on the master registration list. Discrepancies (apart from fencers who have pre-registered and not attended) often occur when pool cards are filled out both at the time of pre-registration and again on check-in, so that two cards exist for a single fencer, or when a fencer registers, but no card is filled out. The number of classified fencers can also be tallied at this time, and cards should be checked one final time for omissions before submission to the Directoire. Classifications and rankings should be verified against the published ranking lists at this time as well. A sample pool /registration card appears as Fig 24.

FIG. 24

NAME		RANK				
CLUB		WEAPON				
ROUND	POOL	VICT.	V. IND.	TD	TR	IND.
C.F.A. #				PAID:		

2.2.4 HANDLING CASH

All personnel working in the registration area should be under the the supervision (and trained by) the committee member responsible for registrations, with the exception of those handling cash. Registrations for large competitions may involve very large amounts of cash, so adequate security precautions are essential. Large amounts of cash should never be kept in the registration area itself, and a specific individual should be responsible for taking cash and making change at all times. This person should obtain an adequate cash float from which to make change during early registrations, and remove specific amounts of cash at regular intervals to prevent large amounts from accumulating at the registration desks. One method of accounting for cash transfers is to count specific amounts into envelopes, which are then sealed, initialled by the accountant, and transferred to a safe place. A receipt stating the envelope number and amount is given by the accountant in return and filed in the cash-box or till. Thus the total cash on hand can be determined at any time, but the actual cash is safely stored. It may even be deposited to a bank account, if the facilities are at hand.

Disbursements for petty cash (food, refreshments etc.), honoraria and other expenses may be made directly from the cashbox, provided that this is specifically authorised by the accountant, and a receipt is signed by the recipient, initialled by the accountant, and retained in the cashbox or till. It is preferable from an accounting standpoint to have such payments made by cheque, but many of the payees are not in a position to cash cheques, so cash should be used, provided that it can be accounted for properly.

2.3 RUNNING THE COMPETITION

2.3.1 DIRECTOIRE TECHNIQUE

The running of competition is governed by Part V of the Regulations for Competitions. Reference should be had to Articles 501-555, and also 557-569, if teams events are planned.

Since it may serve as jury-d'appel, the Directoire should be composed of at least three individuals. Normally one of these will be the chairman of the organising committee. The other two (or more) should be senior and experienced members of it as well. Members must be completely familiar with relevant rules and have the ability to calmly and rationally assess arguments and resolve disputes.

Since they will be allocating presidents of pools, a good familiarity with the skills of those present is an asset. Credibility with the coaches and competitors is also important, and this may be enhanced by adding members from other clubs or regions, if qualified persons are present.

Once the membership is determined, however, it should be posted in a conspicuous place before competition begins, and not changed thereafter. Since it may be required to vote to resolve disputes, it should have an odd number of members if possible.

2.3.2 DETERMINING FORMAT

Unless one has the luxury of a 100% pre-registration, the format cannot be set until after the close of registrations. It is generally a compromise between attempting to run the competition as efficiently as possible, and allowing the maximum possible number of bouts for each competitor. If the competition is a large, high-level one, it may be desirable to eliminate as many fencers as early as possible, so as to free up piste space and officials for later rounds or other events. If it is a small or unclassified competition, on the other hand, it may be preferable to be more generous, not eliminating fencers early on so as to permit them to gain experience. Note that it is not permitted to eliminate more than 50% of competitors in any single round²⁵. Once the format has been established, it should be publicly announced, and a copy posted in a prominent place. It cannot be changed once competition has been started.

The following factors should all be considered:

- number of competitors,
- number of available pistes (no. of pistes, scoring apparatus, or presidents, whichever is least),
- overlapping of rounds and separate events,
- number of competitors to be eliminated in each successive round
- nature or philosophy of the competition (efficiency vs. experience for beginners)

2.3.2.1 Pools (Fig. 25, page 104)

Preliminary rounds are usually composed of pools, which promote or eliminate on aggregate results, as opposed to eliminations, which depend on the outcome of a single bout (or two, if there is a repechage). Note that, as each fencer is added into a pool, the number of bouts that must be fenced increases by the number of fencers already in that pool. The actual number of bouts is expressed by $N(N-1)$, where N = the number of fencers in the pool. Thus a pool of 5 fencers will require only $5 \times 4 \div 2 = 10$ bouts, 6 fencers will require 15 bouts, 7 will require 21 bouts and so forth. The geometric increase in the number of bouts means that it will usually be more efficient to fence a first round in two flights than to compose large pools if the number of available pistes is restricted. Consider the following problem:

Entry: 70 fencers	No. of pistes: 10
Format #1: 10 pools of 7 @ 21 bouts each.	Total: 210 bouts
Format #2: 14 pools of 5 @ 10 bouts each.	Total: 140 bouts

25. See Regulations for Competitions, Articles 522, and 550.

The second format permits all pools to be fenced out faster, and also allows the pistes from the fastest first-flight pools to be re-used soonest. This is particularly significant in first rounds, where the composition of pools is often not uniform. For example: 74 fencers, 10 pools of 5 fencers, and 4 pools of 6. Pools of more than 6 fencers in a first round are almost never practical unless the goal of the competition is to maximise experience for beginners.

The Regulations for Competitions prohibit the use of uneven pools except in first rounds, so the first round must reduce to a number of competitors evenly divisible by the number of second-round pools desired. They also prohibit pools of fewer than 4 competitors.^{25B}

2.3.2.2 Direct eliminations (Fig. 26, page 106)

Direct elimination tableaux, even with repechage, are generally faster than pools, and this is even more true for women's events, where bouts are still fenced to only 8 hits. Tableaux of 32 or 64 fencers also have the advantage of making collusion between competitors during the preliminary rounds much more difficult because the precise position on a larger tableau is more difficult to predict in advance.

A new anti-collusion format is now being tested by the F.I.E. in which the direct elimination repechage tableau can only lead to the final bout for third place. Thus a loss anywhere in the direct elimination series makes it impossible to win the competition.

The chart in Fig. 25 illustrates how uneven numbers of competitors can be rounded off into "perfect" numbers in an uneven first round, and how subsequent rounds will reduce the numbers to tableaux of 64, 32, 16, or 8 fencers for a direct elimination final. Begin with the total entries, and look for the higher "perfect" numbers below it. The critical factors in reaching this number in a single round are the number of pools to be fenced and the number of fencers to be promoted from each. Thus, if the competition has 89 fencers entered, 80, 72, 64, 60, and 48 are all possible. Numbers below 44 are not possible because they would require the elimination of more than 50 % of the competitors in one round. 80 is possible but not very practical because it requires a full round of competition to eliminate only 9/80ths of the entry. The choice between 72, 64, 60, and 48 will depend on the philosophy of the competition (i.e.: to determine a champion, or to provide experience for beginners), and to other considerations, such as the number of pistes or presidents available. If only 10 pistes are available, for example, the first round will have to be fenced in two flights, but eliminating down to 60 or below will permit the second round to be fenced in a single flight without having to resort to pools of 7 fencers.

Once the desired number has been chosen, dividing it by the number of fencers to be promoted will generate the number of pools required. Thus, if 72 is chosen for example, dividing it by 3, 4 or 5 should generate possible numbers of first round pools. Since 72 is not divisible by 3 or 5, the only possibility is $72/4 = 18$ pools, with 4 promoted. Dividing the Coal entry, 89, by the number of pools, 18 will then give the number of first round pools required. $89/18 = 4 + 17/18$, or pools of 4 with enough pools of 5 to include the extra fencers. Thus the first round would be 17 pools of 5, and one pool of 4, with four promoted.

25B. See articles 515 (minimum number) and 516 (uneven pools).

If 10 pistes are available, this may be the best format. Since two flights will be required no matter what the first round format, a fairly high number of small pools (4 and 5 instead of 5 and 6) will be faster than a smaller number of larger ones.

The possibility of eliminating to 64 fencers should also be considered, since this leads into a direct elimination format directly after the first round. As stated above, this is much more efficient, but provides less fencing for the lower-ranked competitors, who will usually be eliminated by the high seeds early on. It should also be borne in mind that this format requires more high-calibre presiding early on, due to the longer bouts, and higher stakes for the competitors. This has the overall effect of shifting much of the presiding work from a large number of less-qualified individuals onto a smaller number of more senior ones, and makes fatigue a problem, especially if other events are being fenced the same day. The same calculation used above yields 9 pools of six and 7 pools of five, with four promoted to reach 64 fencers.

If a fairly large reduction of competitors is desired, it is also possible to fence two complete rounds without eliminating anyone after the first, and then eliminating directly to the desired number based on the aggregate results of both rounds. This is known as the "Brazilian system", and is often done where first round seeding is not well known, or to provide extra fencing for the less-experienced competitors. Under the rules this is considered to be a single first round with no eliminations, followed by a second, distinct round, however, so the maximum elimination of 50% applies to the total of both rounds. For 89 fencers, for example, the first round eliminates no one, so the second can still only eliminate up to 44.

The second round is seeded based on the results of the first, as is any subsequent round, but the organisers have two options for seeding the third round: it can be based on only the second round, or on an aggregate of both rounds. If the rounds are seeded individually, the second round is seeded from the first in the same manner as for promoting fencers in a round where some have been eliminated: pool placings are first determined by victory indicators (# vict. / #bouts), then hit indicators (TD-TR, hits scored minus hits received), then least hits received, in that order. Fencers are then seeded into the second round based on their placings in the first round pools. If the two rounds are to be aggregated, this method would only work if all pools had the same number of fencers. If not, victory indicators (#Vict./#bouts) should be used directly. Thus a fencer who won four bouts in a pool of 5 ($(4/5 = 0.8)$) is seeded ahead of one with four victories in a pool of 6 ($(4/6 = 0.66)$), even though both placed first in their respective pools. Both rounds are aggregated by dividing the total number of victories by the total number of bouts. The specific method to be used for seeding the second and third rounds must be announced to the fencers and coaches before competition begins.

Note that the rules require two evenly-distributed rounds (i.e.: composed of pools with each having the same number of fencers) prior to seeding a direct elimination tableau, and that the seeding be based on the aggregate of both rounds. Thus the Brazilian format can only lead directly into a tableau if all pools were even to begin with. If not, and a large tableau (32, 64, or 128) is desired, it is more efficient to have a single first round to eliminate a small number of fencers (from 89 to 80 or 72, for example) followed by two "even" rounds to permit proper seeding of the tableau.

Fig. 25, is a list of some (but not all) of the possible first-round formats for competitions having up to 120 fencers, and the chart in Fig. 26 illustrates some of the possible elimination formats once a "perfect" number has been reached.

FIGURE 25 COMPETITION FORMATS (PRELIMINARY)

ENTRIES	POOLS (4-6)	PROMOTIONS	TO REACH
0-9	1	-	-
10-12	2	4	8
13-18	3	4	12
19-24	4	3	12
	4	twice	top 16
25-30	5	4	20
	5	twice	top 20
31-36	6	4	24
37-48	8	3	24
	8	twice	top 32
49-60	10	4	40
	10	3	30
	10	twice	top 32
61-72	12	4	48
	12	3	36
73-96	16	3	48
	16	twice	top 64
97-120	20	3	60
	20	twice	top 64

2.3.3 SEEDING

2.3.3.1 First rounds

Since many competitors will present themselves at the first round as an unknown quantity, first round seeding is a more subjective process than subsequent rounds, which are based only on the results of earlier rounds. Where available, fencers should be seeded based on the most recent available national ranking. This should be taken from the national ranking list (or interim list) and entered onto the pool card during the registration process. Classified fencers who do not appear on the list (inactive or foreign fencers) should be seeded at the bottom of that ranking group. Thus, all of the 'A' class fencers are ranked in the order of their national ranking, any unranked A's are inserted at the bottom, and the same process is then repeated for the 'B' class fencers. Where the organisers have reserved the right to vary the rules, it may be possible to rely on subjective assessment of the stronger fencers and to insert them higher up. This is more likely to be significant (and therefore contentious) in a relatively small but strong competition, where very early rounds are more important. In the first round of 18 pools, for example, the seeding is only likely to be questioned if there are more than 18 "A'-class fencers such that they must be unevenly distributed.

Once all of the fencers have been sorted into order, they are laid out across a large surface in columns, one for each pool. They are laid out in order from left to right and right to left in alternating rows, so that a first round of 18 pools would look like this:

1	2	3	4	5	6	7	8	9	10	11	12	13	14	15	16	17	18
36	35	34	33	32	31	30	29	28	27	26	25	24	23	22	21	20	19
37	38	39	40	41	42	43	44	45	46	47	48	49	50	51	52	53	54
72	71	70	69	68	67	66	65	64	63	62	61	60	59	58	57	56	55'
73	74	75	76	77	78	79	80	81	82	83	84	85	86	87	88	89	

Each vertical column then becomes a pool, subject to transfers to avoid club conflicts.

Up to five fencers from the same club, province or country should be protected by seeding them into different pools if possible. This is done by moving each conflicting fencer down the order of seeding the minimum number of places necessary to avoid the conflict. Since the second or subsequent fencer is always considered to be the one in conflict, it is always the lower seeds that are moved. Similarly, they may displace other conflicting fencers from the pools into which they are inserted. Thus in the array above, for example, if fencers 46, 47, 25, 24, and 13 were all from the same club, 13 and 24 have a conflict. 24 (the lower seed) is moved down one pool (to pool #12), which creates a conflict with fencer #25. Since #25 is the lower seed, he, not 24 is then displaced into pool #11, and so forth. A sixth or subsequent fencer cannot be protected from the first five, and no fencer may be advanced into a higher seeding position for purposes of protection²⁶. Note that the number of fencers that can be protected is also limited by the number of pools if there are fewer than five.

26. See Regulations for Competitions, Article 519

FIGURE 26 COMPETITION FORMATS (TO FINAL)

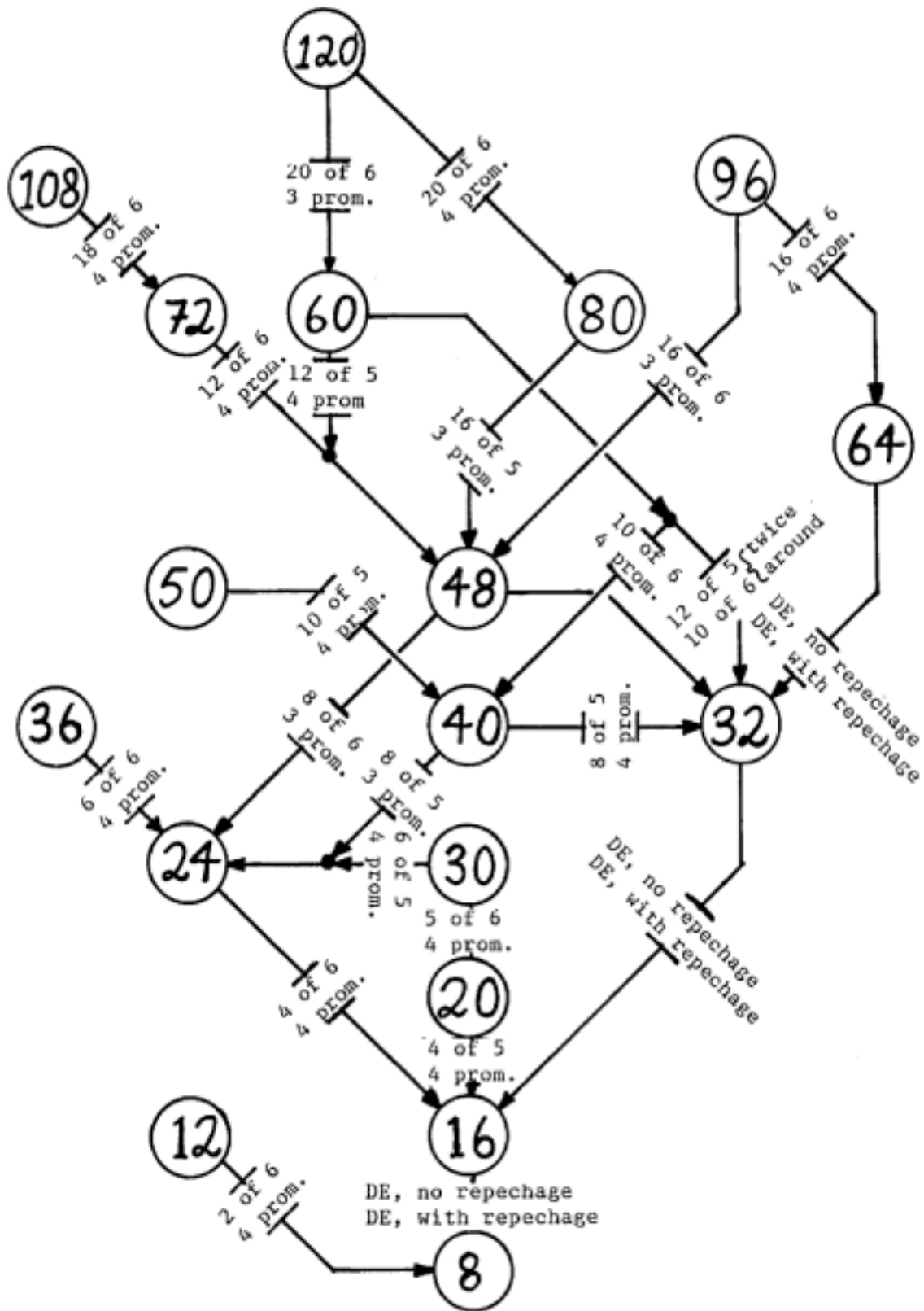

Level IV - Competition

Once the pools are satisfactorily arrayed and double-checked, the names of the fencers for each pool are placed in a random order (shuffle the cards), and transferred onto pool sheets. If two or more conflicting fencers are in the pool, they must fence first, so the order should be adjusted accordingly if necessary. Pools are numbered in order and the number is placed on each pool sheet. A piste assignment and president are added as soon as these are known. If the number of pools exceeds the number of pistes, then the first flight only should be assigned. Thus if 18 pools are to be fenced on only 10 pistes, the first 10 are assigned, and #11 will be assigned to the first available piste as the first flight finishes.

2.3.3.2 Subsequent rounds (pools)

The promotion of fencers to subsequent rounds is governed by Part V of the Regulations, and these must be applied for both promotion and seeding whether any competitors are eliminated in a particular round or not²⁷. An equal number of fencers must be promoted from each pool, with the priority being based on number of victories (or victory indicators if two rounds are aggregated), hit indicators (TD-TR), and least hits received, in that order²⁸. In the event of a tie for promotion based on all three indicators, a barrage must be fought to decide the matter, but this is to be done if and only if promotion or elimination is at stake²⁹. Eliminated fencers are ranked in the same manner, except that tied fencers are both given the same placing, and the next place (or places, in the event of a multiple tie) is not awarded.

2.3.3.3 Direct elimination tableaux³⁰

Tableaux of 16, 32, 64, or 128 fencers must be seeded based on the aggregate results of the two immediately prior rounds, with both rounds having the same number of fencers in all pools. In the event of a tie in victory indicators, hit indicators (TD-TR) are used, in the same manner as for seeding pools. Fencers from the same club or country are protected where possible as in the composing of first round pools, with each quarter (of 4, 8, or 16 fencers) of the tableau treated as if it were a pool for this purpose. Fencers are moved down the seeding list (never up) to avoid conflicts, and the lower seeded fencer is always displaced by the higher. Final placings within each group of eliminated fencers are still determined based on their original seeding into the tableau, however, so this seeding position must be recorded before any fencers are moved. It should be noted in brackets after the fencer's name on the tableau sheet, and recorded on the pool card as if it were a round promotion. Fencers are also protected, where possible, from meeting competitors in the repechage that they have already fenced in prior elimination (not preliminary) bouts. This is done by the same procedure as for protecting clubmates, except that there should be no displacement if it has the effect of creating a club or nation conflict instead. Thus one displaced fencer would in turn displace a lower seed where both needed protection based on earlier elimination bouts, but there would be no displacement if the lower seed would be inserted into a quarter containing a club-mate or countryman.

27. See Regulations for Competitions, Articles 517 and 522.

28. See Regulations for Competitions, Article 517.

29. See Regulations for Competitions, Article 5123

30. See Regulations for Competitions, Articles 549-556.

Level IV - Competition

d) Finals

The final tableau of eight fencers is composed of the final four fencers from the original tableau, plus the four surviving fencers from the repechage, or the final eight competitors from the original tableau if there was no repechage. The survivors of the original tableau are seeded in places 1-4, based on their seeding positions going into the original tableau. The four fencers emerging from the repechage are then seeded into places 5-8 on the same basis. There is no displacement from these places for protection of club-mates at this stage.

2.3.4 Staging the finals

The staging of final rounds should be given extra attention and forethought by all involved. For the public relations department, they are often the best or even only aspect of the competition that can be used for promotional purposes, fund-raising and attracting spectators. For the directoire technique and apparatus departments, they represent more pressure to provide the best possible apparatus and officiating as the calibre of competition increases. The remaining competitors themselves will have invested considerable effort in gaining the final, and will want to concentrate on the fencing and minimise distractions as much as possible. They, especially, deserve the most efficiently-run and expeditious final possible within the ability and resources of the organizing committee.

Officials should be chosen with care, and for their demeanor as well as presiding ability, especially if there is to be media coverage or a large number of spectators present. For a final of eight, there should be two presidents, judging alternate bouts. The piste should be equipped with the best apparatus available, and audio-visual aids such as overhead displays and publicaddress systems should be used if available. Finalists should be introduced to the audience, and may be assigned numbers for media identification if this was not done earlier. Trophies or other awards should be laid out in view of the audience beforehand, and be readily at hand to permit a smooth presentation ceremony as soon as possible after the conclusion of the fencing.

2.3.5 Tabulation, recording and reporting of results

As each round of competition finishes, the pool cards of promoted fencers are first ranked and sorted into pools for the next round. As soon as score sheets are filled out and fencing commences, the cards of the eliminated fencers should be sorted using the same basis as for determining promotion, and placings entered onto a master list of finishing places. As the competition proceeds, this list will gradually be filled out from the bottom up. Passports should be completed for the eliminated fencers at this time as well, as many will wish to leave before the fencing finishes. If the competition is to be used for CFF national standings, the results must be recorded on the correct forms. These must be correctly filled out, signed by an authorized member of the Directoire, and returned to the office within 7 days of the finish of competition, along with the prescribed per capita payment, if any. If the competition is to be staged annually, copies should be retained by the public relations officer as an official record and for use in promoting future events. As a courtesy, certified copies of this list should also be sent to any other provincial or national federations represented at the competition.

2.3.6 Apparatus (See also Module 1)

Armouring a large competition is a demanding and exhausting business. Technicians will often be called upon to make reliable judgments and perform precision tasks while overtired, or under unfavourable conditions. The best possible preparation for this, aside from actual experience, is to develop a system or set of procedures for assessing problems as they arise and implementing solutions.

This principle applies at all levels of organisation. Thus there should be a system or roster for ensuring that sufficient trained personnel will be on site at all times, with more at peak times. There should also be a system for those technicians to follow in diagnosing and repairing specific technical problems as they arise. There should be a clearly marked repair shop or area, and one technician should always be in or near it so as to be available on demand. Another should be making regular sweeps of the venue monitoring the condition of pistes and other apparatus and collecting broken cables and reels for the shop. This is particularly important during the advanced rounds when apparatus is often replaced from adjacent unoccupied pistes instead of the spare supply in the shop area. Technicians should be readily identifiable as such, if possible. This makes them easier to locate, and avoids problems that can arise from presidents obtaining technical advice from unauthorized or unqualified sources.

Develop a system for troubleshooting on the piste when called upon, and insist that it be followed consistently, even in the face of opposition from competitors, coaches, or officials. Technicians should not go onto any piste unless specifically asked to do so by the President, but once there, must take charge of the situation. No one apart from the two fencers, the President, and the technician himself should be allowed onto the piste, and no one should carry out any diagnostic testing or replacement of equipment but the technician. When called to a piste, the technician should first check that no apparatus has been changed, and then instruct that no changes be made without his instructions. This should be done regardless of whether the president or technician suspects a specific problem: ultimately the technician may be asked to give an expert opinion as to the cause(s) of the problem, and hits may be awarded (as penalties) or taken away (doubtful hits etc.) as a result. An accurate opinion cannot be given without a complete assessment, and cannot be reversed or altered once fencing re-commences.

Similarly, there should be a clear system for marking defective or suspect equipment and for subsequent assessment in the shop area, to avoid the possibility of defective equipment being taken back into service before it is fixed. There should be a clearly marked area for serviced equipment, ready for use, and the shop technician should always be on hand to receive defective equipment and ensure that it is not placed in this area. A system of marking defective equipment using tags or labels may also be useful, especially if diagnosis and repairs are carried out by different people or at different times. One simple method for marking cables, bodywires, and reels, is to tie a knot in them at one or both ends. A specific, unusual knot (such as the figure-eight knot) further reduces the chances of confusion.

III - POST COMPETITION MATTERS

3.1. Accounting

The accounting system used during and after the competition need not be sophisticated or complex to be effective in controlling the intake and expenditure of money. It must be straightforward and easily understood by all members of the organising committee who must supply the necessary information, and it should be clear enough to satisfy outsiders, such as potential sponsors who may review it from time to time. Accurate financial statements are important evidence that money is handled responsibly, which greatly assists the public relations or fundraising departments in soliciting donations and sponsorship of other kinds. Statements and balance sheets also help the organising committee in future years, by demonstrating which areas of the competition were profitable and which were not, and often why not.

The committee treasurer, who will handle all of the accounting and prepare a financial statement, should be present during the competition to supervise the collection and handling of cash, cheques, receipts and other documents he will need later on. The person responsible for collecting these things in each department should turn these over to the treasurer at the end of the competition, along with a written statement "balancing" the total amount taken in against the amount turned over minus any amounts paid out. This may even be done daily, especially if the competition lasts several days and relatively large amounts of cash are involved. To avoid large accumulations of cash, a series of temporary balance sheets may be used as it is collected. At the end of day one, for example, the registration department may hand over an envelope of cash and receipts for that day, or if a bank deposit is made, a receipt for that balanced against registrations and expenditures.

A sample balance sheet for one or more days of competition appears below as Fig. 27, page 112. It would be accompanied by either #2,598.12 in cash and/or cheques, or by a bank receipt for that amount, a registration list to verify the number of entries, and receipts from presidents (including those who obtained refunded entries), recipients of petty cash, etc. Any payments of cash or waiving of entry fees should be matched by a receipt, so a book of blank receipts should be kept on hand by the registrar or treasurer. It is not necessary to obtain receipts where money is paid by cheque, but presidents will wish to be paid cash where possible.

Once all funds and related documents are in the hands of the Treasurer, he or she may attempt a trial balance. Cash and cheques must be carefully counted if not already deposited, and any discrepancies between the correct totals and original totals should be noted. Funds that were incorrectly counted at first should have generated a discrepancy, since these should have been balanced against other figures (receipts, entries, etc.) by the person who submitted them. The Treasurer will then list all discrepancies, and attempt to reconcile them against each other. Once this has been done, a final balance may be struck and a financial statement drawn up.

FIG. 27 SAMPLE BALANCE SHEET (STATEMENT FROM REGISTRATIONS)

From: _____ SIGNED: _____
 Day(s) ending: _____

RECEIPTS/DOCUMENTS ENCLOSED	AMOUNT	
- ENTRY FORMS (TOTAL REGISTRATIONS)		
- 50 @ \$14.00 (F.M. JUNIOR)	\$700	00
- 80 @ \$18.00 (F.M. SENIOR)	\$1440	00
- 14 @ \$14.00 (SABRE JUNIOR)	\$196	00
- 22 @ \$18.00 (" SENIOR)	\$396	00
- OTHER RECEIPTS		
- NONE	NIL	-
- TOTAL RECEIPTS	\$2732	00
<hr/>		
DISBURSEMENTS (RECEIPTS/VOUCHERS ATTACHED)		
- REFUNDED ENTRIES		
- NO-SHOWS: 2 @ \$18.00 (A. SMITH K. DOE)	\$36	00
- PRESIDING HONORARIA		
- B. DOE \$18.00		
- H. LEE \$18.00		
- N. MARSH \$14.00		
TOTAL \$50.00	\$50	00
- PETTY CASH (RECEIPTS ATTACHED)	\$47	88
- TOTAL DISBURSEMENTS	\$133	88
<hr/>		
FUNDS DEPOSITED/ATTACHED		
- CHEQUES \$918.00		
- CASH \$1680.12		
TOTAL \$2,598.12	\$2598	12

SUMMARY: RECEIVED \$2732.00
 DISBURSED \$133.88
 DEPOSITED \$2598.12
 UNACCOUNTED FOR. - NIL.

Petty cash may be paid out to committee members in advance, to be spent on postage, tape for pistes, and the like. A receipt should be obtained at the time it is paid over (unless paid by cheque), and the Treasurer should keep a list of which members have petty cash outstanding and specific amounts owing. A simple list will usually suffice, but if this becomes complicated a ledger, having a page for each member of the committee, may be necessary. Each member, having petty cash out is then responsible for repaying it, or for furnishing itemised receipts for what has been spent. A petty cash statement should be completed by each member and submitted to the Treasurer once all expenditures have been made. Since the amount actually spent will not usually match the cash float exactly, some money will have to be paid one way or the other to balance the account. Thus, if the float was \$100.00 and the amount spent was \$106.37 \$6.37 should be paid over to the member, and a receipt obtained. This may be incorporated right into the petty cash statement. A floating petty cash account may be useful if a particular member is spending fairly large amounts, and it is not practical to have suppliers bill the Treasurer directly. This involves payment out of an initial float, and then replenishing it as necessary in exchange for receipts. Thus the first payment would be a fixed amount, and subsequent ones would be in the same amounts as submitted receipts so as to maintain the same total float.

FIG. 28 SAMPLE OF PETTY CASH RETURN STATEMENT

#	RECEIPT FROM	PARTICULARS	AMOUNT
1	AL'S VARIETY	COFFEE, CREAM & SUGAR	\$ 16 45
2	POST OFFICE	INCIDENTAL POSTAGE 25 @ 40¢	\$ 14 —
3	CAN. TIRE	BOLTS, TAPE, SOLDER, LIGHT BULBS FOR APPARATUS	\$ 62 17
4	JOE'S COPY CENTRE	PHOTOCOPIING PAPER SHEETS, TABLETS, RESULTS	\$ 13 95
TOTAL :			\$ 106 37
AMOUNT PREVIOUSLY DISBURSED (FLOAT)			\$ 100.00
AMOUNT OWING TO: J. DOE			\$ 6.37
RECEIVED BY: <u>J. Doe</u>			DATE 12 MAY '85

FIG. 29 SAMPLE FINANCIAL STATEMENT

ONTARIO CUP COMPETITION
FINANCIAL STATEMENT

Competition held at Anyplace Recreation Centre, anyplace, Ont., May 3-4,1987

TOTAL ENTRIES: 252

RECEIPTS:	AMOUNT	TOTAL
Entries - Senior: 152 @ \$18.00	\$2636.00	
- Junior: 100 @ \$14.00	\$1400.00	
Sale of T-Shirts: 150 Q \$8.00	\$1200.00	
Sale of coffee and sandwiches	\$477.28	
TOTAL RECEIPTS	\$5813.28	\$5813.28
 EXPENDITURES (Receipts on file)		
Trophies and awards (1-8th place × 5 events)	\$800.00	
Venue rental (2.5 days)	\$1172.00	
Printing (entry forms, pool sheets)	\$ 277.24	
Purchase & printing of T-Shirts	\$ 450.00	
Postage	\$ 158.50	
Honoraria for presidents (includes refunded entries)	\$ 720.00	
Apparatus rental (12 sets)	\$1200.00	
Petty cash expenditures	\$ 523.16	
TOTAL EXPENDITURES	\$5300.90	\$5300.90
 BALANCE (Deposited to club operating account)		 \$512.38

SIGNED: _____
Treasurer

3.2. Dismantling the competition

If the set-up crew has done its work well, the task of dismantling should be fairly easy, provided that sufficient assistance is available. It will usually be possible to begin removing pistes two or three hours before the last event actually finishes, as all of the pistes will not be needed for the direct eliminations and finals. As competition winds down, the armourer must stay in close contact with the Directoire Technique to ensure that time is not lost if fencing finishes before the crew is ready, and that pistes are not dismantled before the competition is finished with them. This is a particular risk when bystanders see one piste being taken up by the crew and mistakenly assume that others can be removed as well.

As with the set up, the tear-down crew should be split up into groups to maximise the benefits of the most experienced workers by pairing with less experienced ones. Specific individuals should also be assigned to the same areas they were involved in during the set up, if possible. The person who drew up the inventory list of equipment during the set up should always be assigned the task of sorting the labelled equipment back into the appropriate boxes and checking each off against his list. He should line up the numbered cases in order at one side of the gym, and sort equipment into them as it becomes available. Equipment that has lost number tags etc. can usually be sorted by process of elimination at the end. He/ she should be aware of equipment that has been taken away early (usually by departing competitors), and should be available during the final day to retrieve equipment as necessary for those who depart early.

As with the set up, it is preferable to have a small number of crews each working on one piste, so that only a few pistes are being taken up at any one time. This minimises the risk of damage to metallic pistes from spectators tripping over the exposed edges. It may also be advisable not to begin dismantling any piste in an area that is heavily occupied or travelled. Always stay as far away from the crowds as possible, and do not start to dismantle a piste until the job can be finished completely.

Begin by sweeping the piste with a broom or mop, and then unbolt and remove the stretch hardware from the corners. As pistes are swept, they should be inspected and marked for later repairs if any damage is found. Lay out the case if there is one, at one end, and then begin rolling at the other. As two people roll the piste, another pair lifts the edge tapes, so that the piste edges are not left exposed for any length of time. If cases are used, they should be laid out on one side, so that the piste can be rolled directly in without lifting. Before pistes are put into cases they should be wrapped with tape to prevent them from expanding inside the case and jamming.

Other apparatus should also be inspected and repaired as necessary before it is packed. Spectators and bystanders will usually offer to assist in the tear-down. They should not be discouraged from doing so, but should be paired off with existing teams rather than being left to work on their own. This makes the best possible use of volunteers and prevents problems that can result when they attempt to strike the wrong apparatus at the wrong times.

A single technician should be assigned the job of dismantling the repair shop, but this should only be done after all pistes and equipment are accounted for, since last-minute repairs may be necessary. All borrowed equipment must be checked and serviced if necessary before being returned.

3.3. PUBLIC RELATIONS

The public relations member should ensure that a complete and accurate results list is compiled as soon as possible after competition finishes. If possible, some biographical information should be obtained from each of the winners for use by the media. At minimum, clubs, home cities, coaches etc. should be obtained. Fencing histories, past results etc. are also useful. Specific note should be made of local fencers results as well.

He or she should also determine reporting deadlines for both the local media and wire services and attempt to deliver as much of the results as possible in time after the finish of each day's fencing.

3.4. POST MORTEM (closing meetings)

The committee chairman should call a closing meeting about two weeks after the competition. This will permit sufficient time for each member to complete his responsibilities, but is still soon enough after the competition to permit useful discussion of what went on and how to improve it in subsequent competitions. Each member should submit a report outlining his responsibilities and describing how they have been discharged, or if not, why not. The Treasurer, for example, will submit a balanced financial statement and supporting documents, and be prepared to discuss areas that were particularly profitable (or unprofitable) and why. Improvements for later competitions should be agreed upon, and the chairman should make notes for later reference. These will then be used to set up the initial meeting of the next organizing committee.