

BIAX (TT5) 1 or 2x55W, 50W LINEAR HO T5 1 or 2x54W or 2x39W

Programmed Start (Low Profile, High Case Temperature)

Programmed Start (Series) Universal Voltage 120V-277V or 347V, High Frequency Electronic ballast for one or two (1 or 2) Biax (TT5) 55W, 50W, Linear HO T5 54W, or two (2) Linear HO T5 39W GE, Philips, Osram Fluorescent lamps.

Technical Specification:

UL Listed, CUL Certified, ROHS compliant
EMI FCC Parts 18, Subparts C, Class A
Rating: Type 1 Outdoor, HL
Sound Rating: Class A
Min. Starting Temp : - 30° C
Max. Case Temp: 90° C
End of Lamp Life Protection Circuit

Surge Protection:
Thermal Protection:
Lamp Current Crest Factor:
Remote Mounting Distance:
Power Factor:
Input Frequency:
THD:

Meets ANSI C62.41
CLASS P
< 1.6
21 ft
0.99
50/60HZ
< 10%

Case Size: Series E3

Due to continuing efforts to offer improved products all specifications are subject to change without prior notice

9/09/07

NO. OF LAMPS	INPUT VOLTAGE	LAMP WATTS	INPUT WATTS AVERAGE	MAX INPUT CURRENT (A)	BALLAST FACTOR	MODEL
2 & 1	120V	54/55	117/63 & 111/61	0.97/0.52 & 0.92/0.50	1.0/1.05	NU255T5-ROHS
2 & 1	277V	54/55	117/63 & 111/61	0.42/0.22 & 0.40/0.22	1.0/1.05	"
2 & 1	347V	54/55	117/63 & 111/61	0.33/0.18 & 0.31/0.17	1.0/1.05	NC255T5-ROHS

LIMITED WARRANTY

5 YEAR at maximum case temperature 75 deg C. 3 YEAR at maximum case temperature 90 deg C. Manufacturer warrants to the purchaser: Electronic Ballast will be free from defects in material or workmanship from the date of manufacture conditioned upon proper storage, installation, use, and maintenance and conformance with any recommendations of Manufacturer.

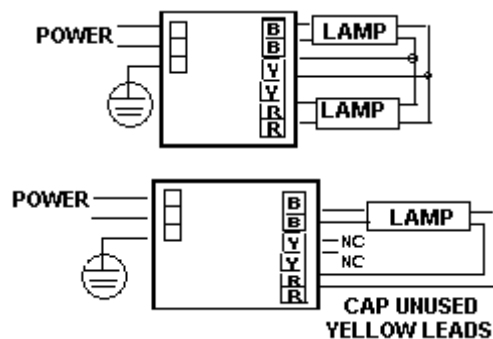
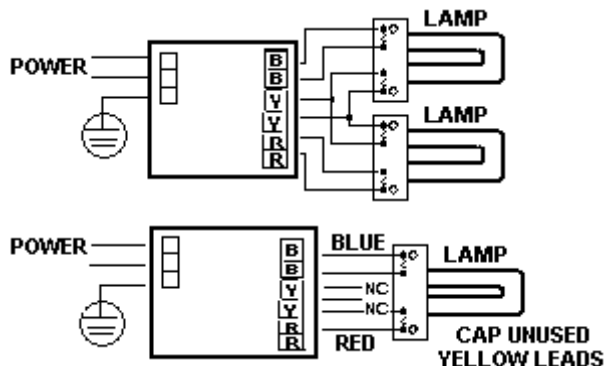

WARNING: Always Disconnect Power Before Handling.
Case Should be Grounded. Install in Accordance
with National and Local Electrical Codes.

Case Size: L W H ML
Series E3 325 mm 34mm 29mm 317mm
12.8inch 1.34inch 1.14inch 12.48inch

1500 Marine Drive, #200 North Vancouver, BC V7P 1T7
TEL: 604-904-9533 FAX: 604-904-9634
EMAIL: sagelighting@shaw.ca www.sagelighting.com

*Sage
Lighting Ltd.*