

Up/Down Counter

[Download this project in PDF](#)

[One Digit](#)

[Two Digits](#)

[Up/Down Counter](#)

[Three Digits](#)

[Shuffle Score Board](#)



Up/Down Two Digits Presetable Counter

The Two Digit Presetable Up/Down counter uses two different ICs as counters . Two CMOS 4510 presetable counters accomplish the same counting functions as the previous described counter but enable us to preset the counter to count up or down . Two 4511 Decoder/Driver ICs as shown will drive two Common Cathode displays .

- Switch S1 (SP2P) connected to pin 10 of both counter when closed is connected to the positive (+) bus , enable the counter to count up from 0 to 99 and down from 99 when S1 is switched to the Ground side (Open) .
- Switch S2 (push button) allows to reset the counter at any time during the up or down counting mode .
- With the help of the 2N2222 transistor connected to pin 15 of both 4510 ICs , switch S4 when pushed will enter the counts .
- From the count of 9 or the preset digit of the first counter (Units) an overload count is passed from pin 7 of the first counter to pin 5 of the 2nd counter (Tens)

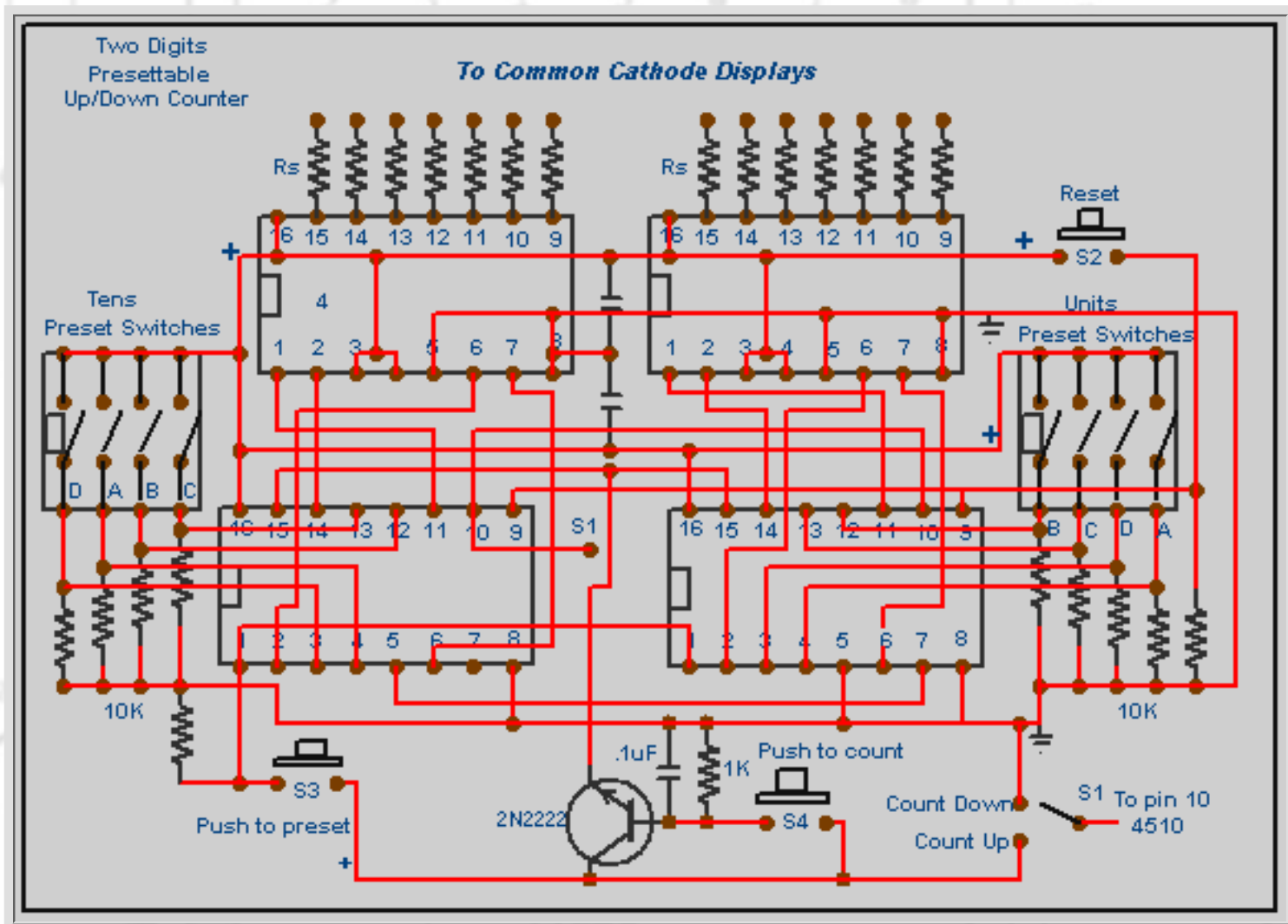

Up Counting

The counting system is a " Four bits " logic counter . Referring to the binary code table shown below will enable you to set each switch to preset the counter to count UP from ' 0 ' to a preset number for each display .

Down Counting

Presetting the counter for a down count is accomplished the same way but the counter will count down FROM a preset number to zero .

Presetting the Counter

Two set of four switches one for each display are provided to preset the counter . As shown below on the BCD table each 4 bit selection is equivalent to a number .To preset that number , set each switch representing the bit value to either the ON or OFF position . Then press S3 to load the preset into the counter then proceed with count .

Exemple : Keeping in mind that to register a "High (1) " logic bit the switch must be closed (connected to positive) and to register a " Low (0) " the switch must be left open . In this case a 10K resistor is connected to ground to hold that bit to ground or " Low (0) " . Using resistors to ground allow us to use cheaper SPST instead of SPDT switches .

Let say we want count to up to or down from the number 25 , we set S1 to UP or Down counting and referring to the table we see that the equivalent of the first number "5" (

Units) is D=0 , C=1 , B=0, A=1 and for the number "2" (Tens) D=0 , C=0 , B=1 , and A=0 . We then select each corresponding switch to set each bit (D,C,B,A) to open for "Low (0) or closed for "High (1)" for each counter then press the preset switch .

If no preset is activated the counter will behave the same as the previously described two digit counter but with the Up/Down and reset selection available .

Bit	Pin-#
D	3
C	13
B	12
A	4

Binaries (4 Bits)				
D	C	B	A	=
0	0	0	0	0
0	0	0	1	1
0	0	1	0	2
0	0	1	1	3
0	1	0	0	4
0	1	0	1	5
0	1	1	0	6
0	1	1	1	7
1	0	0	0	8
1	0	0	1	9

Preset Switch setting
 0 = Open
 1 = Closed (+)

ALERT: The layout and PCB graphics are being redrawn to reflect the change already made to the Push Button trigger circuit on the circuit schematic above . The present PCB can be use by moving the 1K and the .4uF connection from the emitter to the base with a short jumper . .

Construction

A suggested layout is shown below , it is strongly advised that IC sockets be used . Where the Rs resistors are shown 14 pin dip sockets can be inserted and the resistors can be inserted in the socket if preferred which will allow for change of Rs value if required .

The PCB provides for the installation of PC Swiches on board if the counter is to be used for a specific setting or the swiches can be installed at a remote location by using wiring connected from the PCB to the swiches of your choice .

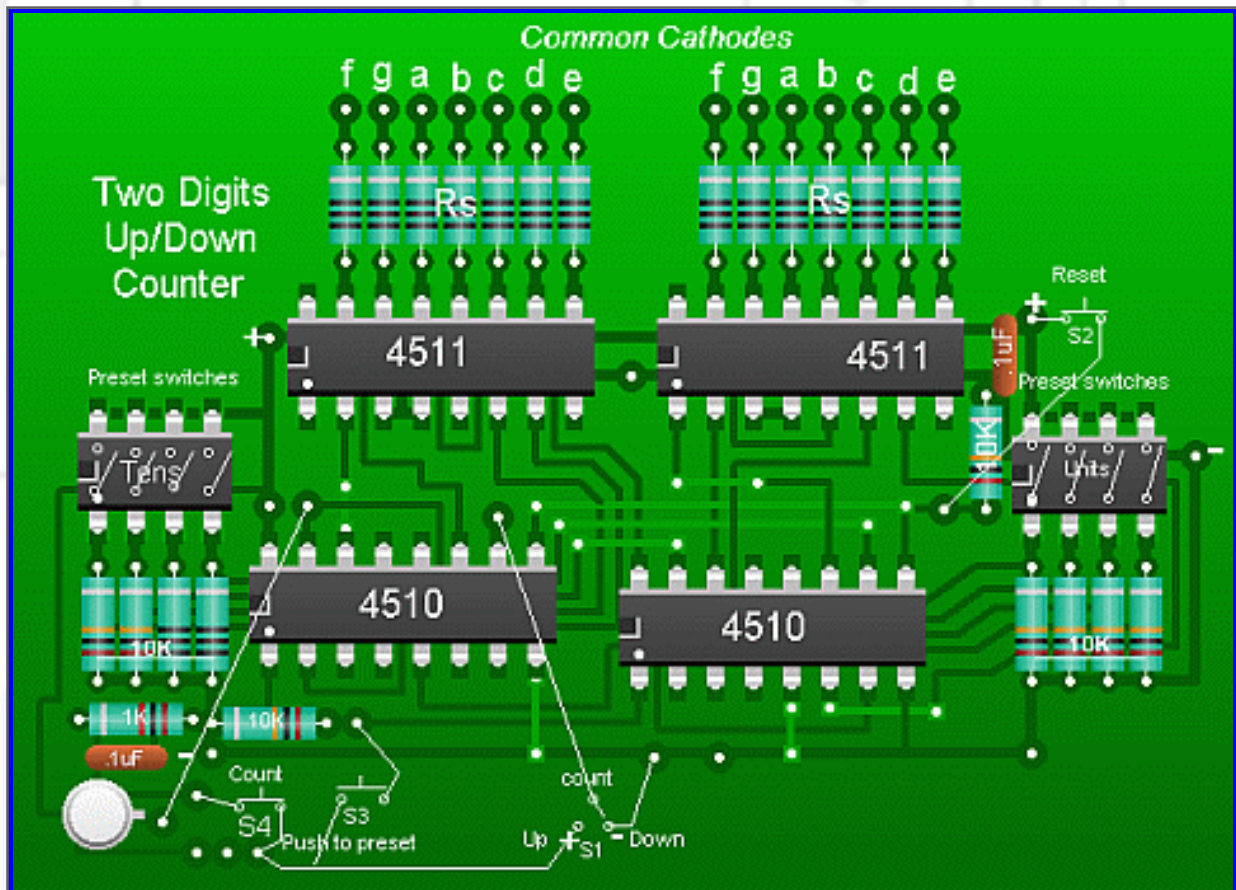
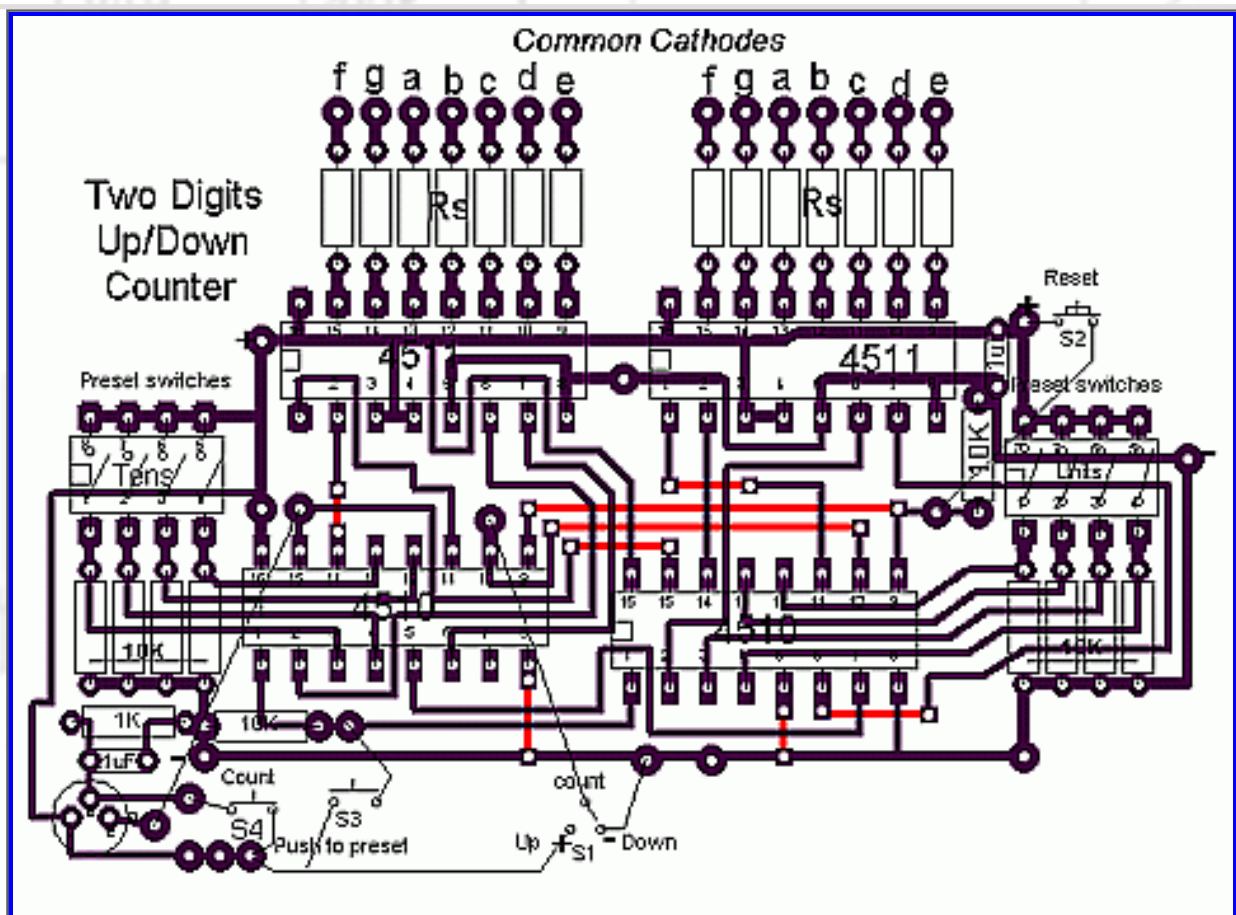

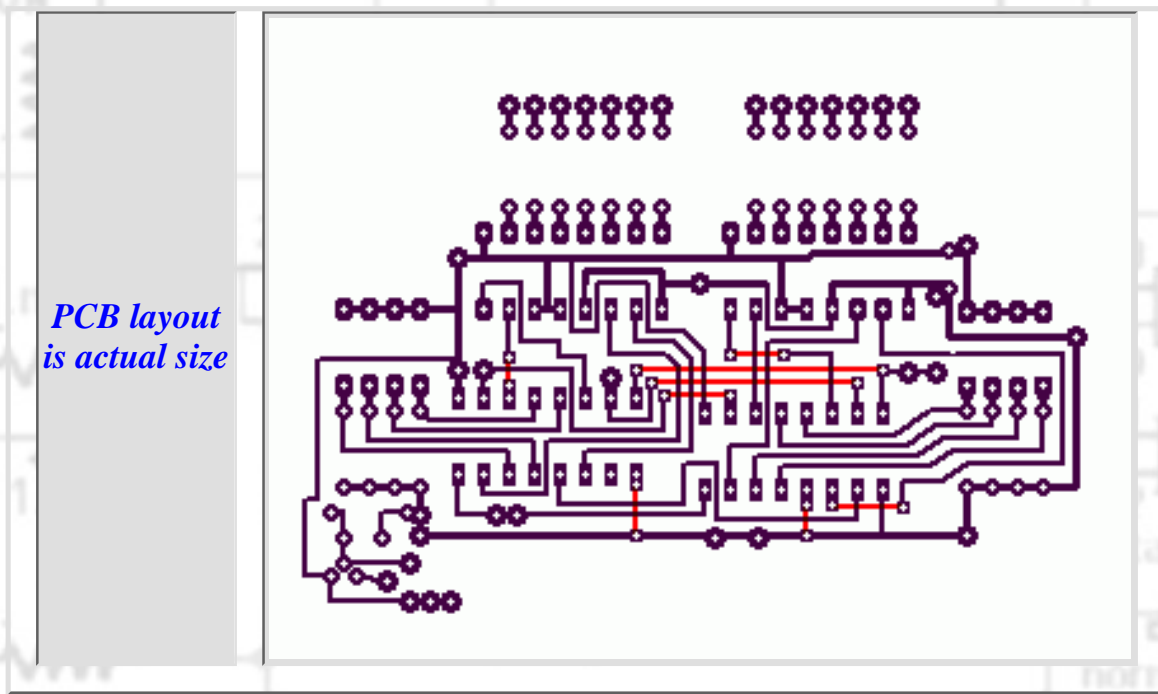

As with the previous counter using the CMOS 4511 Decoder/Driver IC , Common anode and large displays can be used . For details see [Shuffle board](#) .

One Digit	Two Digits	Up/Down Counter	Three Digits	Shuffle Score Board
---------------------------	----------------------------	-----------------	------------------------------	-------------------------------------

