

Ray of Incapacitation

Evocation [Electricity]
 Level: Sor/Wiz 1
 Components: V, S, M
 Casting Time: 1 standard action
 Range: Close (25 ft. + 5 ft./2 levels)
 Effect: Ray
 Duration: Instantaneous
 Saving Throw: Fortitude partial; see text
 Spell Resistance: Yes

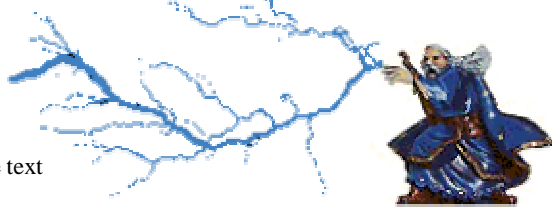

A ray of electrical energy projects from your pointing finger. You must succeed on a ranged touch attack with the ray to strike a target. You gain a +3 bonus on attack rolls if the opponent is wearing metal armor (or made out of metal, carrying a lot of metal, or the like).

The ray deals 1d4 points of electrical nonlethal damage and the target must make a Fortitude saving throw or be stunned for 1d4 rounds. On a critical hit, the target takes 2d4 points of electrical damage. This is normal, rather than nonlethal, damage.

Material Component: A scale from a shocker lizard.

From the Editor:

We're back with a vengeance. After a long dry spell, it's been great to release two issues within a week. Best to strike while the iron is hot, and all that.

Yes, I know tasers and stun guns are already described in the MSRD. It's just that the rules on them are not very good. The MSRD versions paralyze people for a few rounds, which means they are helpless and subject to *coup de grace* attacks. They also do real electricity damage, making it too easy to kill someone. I'd like to think that the rules I've presented here are an improvement.

The spell brings a taser-like attack to Dungeons & Dragons. It's a real shame that there are not more *ray* spells out there. It's a good, solid mechanic -- it deserves to see greater use.

Is there a chance we might see yet another issue published before the new year? We can but hope.

Keep rolling high,
 Roger Carbol -- roger (at) carbol (dot) com
 10 December 2004

EVERYTHING WITHIN THE DOUBLE-LINED
 BOXES IS OPEN GAME CONTENT.

Requires the use of a Roleplaying Game Core
 Book published by Wizards of the Coast, Inc.



KNOWLEDGE (CURRENT EVENTS)

BRINGING REAL NEWS TO D20 SYSTEMS

Police Use Taser On Six-Year-Old

Miami-Dade police shocked a 6-year-old boy with a 50,000-volt stun gun to keep him from hurting himself with a piece of glass he was waving around in a school office, officials confirmed. Police say they followed their Taser guidelines, the child wasn't injured by the shock and he might have hurt himself seriously if they hadn't shocked him.

The boy, who has not been identified, had broken a picture frame in the assistant principal's office and was keeping a security guard at bay when the principal called 911. The police report did not say why the boy was so agitated, but principal Maria Mason told police he had a history of behavioral problems. Mason declined to comment Thursday.

By the time Miami-Dade Officers Marie Abbott and Yolanda Rivera and schools police Officer Valerie Staten arrived, the boy had a cut under his right eye and another on his left hand. The officers tried to get him to put down the shard, according to the police report. Yolanda Rivera contacted a supervisor to see if there was a policy prohibiting the use of a stun gun on a child. There isn't, and the officer was told to do what she felt was necessary. The officers continued to talk to the child, who didn't respond.

When he tried to cut his own thigh, the officers acted. Marie Abbott shocked him with her Taser while Yolanda Rivera grabbed him before he collapsed. The boy was treated by paramedics at the school and taken to Miami's Jackson Memorial Hospital, where he was committed for psychiatric evaluation.

Superintendent Rudy Crew has asked the county's police chief to instruct his officers to "refrain from deploying or discharging Tasers against elementary school students in Miami-Dade Public County Schools."

Shocking force

Taser International Inc., the maker of stun weapons, has watched its stock soar amidst growing concerns about whether the weapons are as non-lethal as advertised. In a report released Tuesday, Amnesty International says stun guns are being abused by police.

A Taser's electrical current overrides the central nervous system for five seconds, temporarily paralyzing targets

Dataport stores date and time of Taser firing

SOURCES: Amnesty International; Taser International

Insulated wires transmit 50,000 volts of electricity through up to two inches of clothing

ID tags ejected like confetti when fired; printed with the serial number

Disposable cartridge uses compressed nitrogen to launch probes up to 21 feet.

Batteries older models use eight AA batteries, newer models are rechargeable

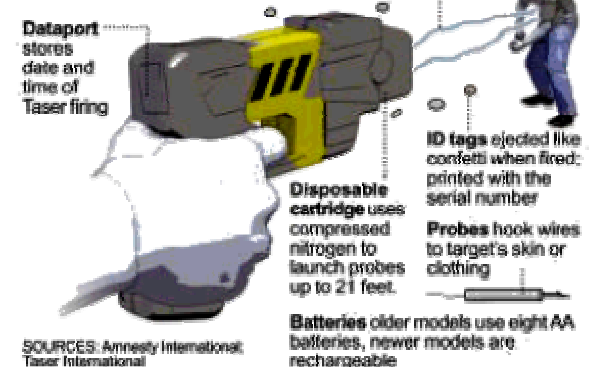

Use of force incidents

At the Orange County, Fla., Sheriff's Office Tasers were the most prevalent force option, constituting 68 percent of all use-of-force incidents in 2002.

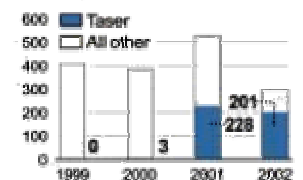

The boy stands about three-feet, five inches tall and maybe weighs 55 pounds, said his mother, Kathy Rojas. She said she is most angered that her son was shocked just "one inch above his genitals."

Police spokesman Bobby Williams said the probes struck him in the middle of his torso and at the bottom of his shirt.

On Friday -- a day after the incident at Kelsey Pharr Elementary School became public -- the little boy sat quietly in his mother's lap, wrapped in a Mickey Mouse comforter.

"I never want to go back to school," he said. ☺

ISSUE #8

- News: Police Use Taser on Six-Year-Old
- Equipment: TASER X26
- Spell: Ray of Incapacitation



TASER X26

Damage: 1d4 nonlethal
Critical: 20/special
Damage Type: Electricity
Range Increment: 5 ft.
Rate of Fire: 1
Magazine: 1 int.
Size: Small
Weight: 2 lb.
Purchase DC: 19 (\$800)
Restriction: —



The TASER X26 is a conducted energy weapon that utilizes compressed nitrogen to shoot two small probes up to 15 or 21 feet (21 foot cartridges sold to law enforcement and aviation security agencies only). These probes are connected to the weapon by high-voltage insulated wire. When the probes make contact with the target, the TASER X26 transmits powerful electrical pulses along the wires and into the body of the target through up to two inches of clothing.

Each air cartridge is serial numbered. This unique serial number is duplicated on up to 40 AFID (Anti-Felon Identification) tags, which are similar to pieces of confetti. These are stored inside the air cartridge and are expelled along with the two probes and so are deposited at the scene of the use of the X26. An internal computer also records the time of every shot.

On a successful hit, the darts deal 1d4 points of electrical nonlethal damage and the target must make a Fortitude saving throw (DC 18) or be stunned for 1d4 rounds. Reloading the X26 by replacing the air cartridge is a full-round action that provokes attacks of opportunity.

On a critical hit, the target takes 2d4 points of electrical damage. This is normal, rather than nonlethal, damage.

The X26 has an integrated laser sight which grants a +1 equipment bonus on all ranged attacks.

When fired at a distance, the X26 requires the Personal Firearms Proficiency feat. It may also be used as a physical contact weapon in melee, which requires the Simple Weapons Proficiency feat. It can be used in melee regardless of whether the air cartridge is expended or charged, present or removed.

Ammunition

Civilian Air Cartridges (15' range): Each: Purchase DC 6 (\$17), 2 ounces. Box of 28: Purchase DC 17 (\$475), 4 pounds. Unrestricted.

Police Air Cartridges (21' range): Each: Purchase DC 7 (\$22), 2 ounces. Box of 28: Purchase DC 18 (\$615), 4 pounds. Restriction: Licensed (+1).

How Stun Guns Work | Standard Contact Stun Gun

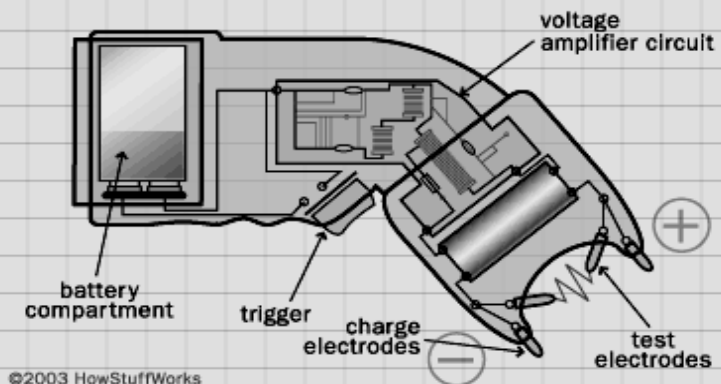

How Stun Guns Work | The Basic Taser Stun Gun

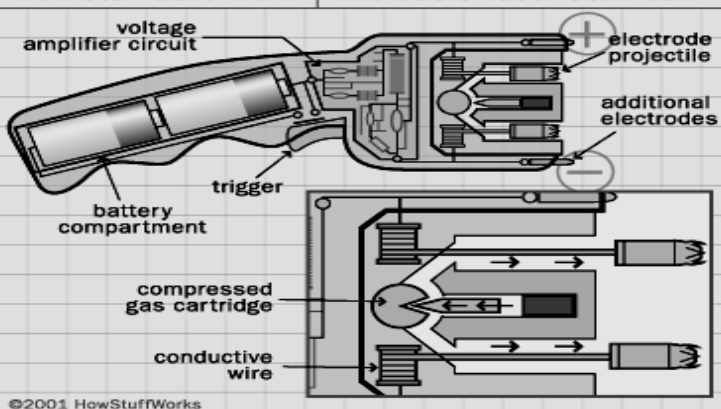

How Stun Guns Work | Liquid Stun Gun Prototype

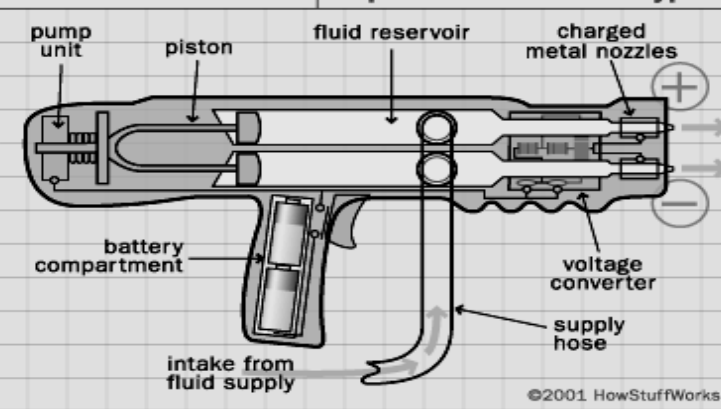

The following text is the property of Wizards of the Coast, Inc. and is Copyright 2000 Wizards of the Coast, Inc ("Wizards"). All Rights Reserved.

1. Definitions: (a)"Contributors" means the copyright and/or trademark owners who have contributed Open Game Content; (b)"Derivative Material" means copyrighted material including derivative works and translations (including into other computer languages), potation, modification, correction, addition, extension, upgrade, improvement, compilation, abridgment or other form in which an existing work may be recast, transformed or adapted; (c) "Distribute" means to reproduce, license, rent, lease, sell, broadcast, publicly display, transmit or otherwise distribute; (d)"Open Game Content" means the game mechanic and includes the methods, procedures, processes and routines to the extent such content does not embody the Product Identity and is an enhancement over the prior art and any additional content clearly identified as Open Game Content by the Contributor, and means any work covered by this License, including translations and derivative works under copyright law, but specifically excludes Product Identity. (e) "Product Identity" means product and product line names, logos and identifying marks including trade dress; artifacts; creatures characters; stories, storylines, plots, thematic elements, dialogue, incidents, language, artwork, symbols, designs, depictions, likenesses, formats, poses, concepts, themes and graphic, photographic and other visual or audio representations; names and descriptions of characters, spells, enchantments, personalities, teams, personas, likenesses and special abilities; places, locations, environments, creatures, equipment, magical or supernatural abilities or effects, logos, symbols, or graphic designs; and any other trademark or registered trademark clearly identified as Product identity by the owner of the Product Identity, and which specifically excludes the Open Game Content; (f) "Trademark" means the logos, names, mark, sign, motto, designs that are used by a Contributor to identify itself or its products or the associated products contributed to the Open Game License by the Contributor (g) "Use", "Used" or "Using" means to use, Distribute, copy, edit, format, modify, translate and otherwise create Derivative Material of Open Game Content. (h) "You" or "Your" means the licensee in terms of this agreement.
2. The License: This License applies to any Open Game Content that contains a notice indicating that the Open Game Content may only be Used under and in terms of this License. You must affix such a notice to any Open Game Content that you Use. No terms may be added to or subtracted from this License except as described by the License itself. No other terms or conditions may be applied to any Open Game Content distributed using this License.
- 3.Offer and Acceptance: By Using the Open Game Content You indicate Your acceptance of the terms of this License.
4. Grant and Consideration: In consideration for agreeing to use this License, the Contributors grant You a perpetual, worldwide, royalty-free, non-exclusive license with the exact terms of this License to Use, the Open Game Content.
- 5.Representation of Authority to Contribute: If You are contributing original material as Open Game Content, You represent that Your Contributions are Your original creation and/or You have sufficient rights to grant the rights conveyed by this License.
- 6.Notice of License Copyright: You must update the COPYRIGHT NOTICE portion of this License to include the exact text of the COPYRIGHT NOTICE of any Open Game Content You are copying, modifying or distributing, and You must add the title, the copyright date, and the copyright holder's name to the COPYRIGHT NOTICE of any original Open Game Content you Distribute.
7. Use of Product Identity: You agree not to Use any Product Identity, including as an indication as to compatibility, except as expressly licensed in another, independent Agreement with the owner of each element of that Product Identity. You agree not to indicate compatibility or co-adaptability with any Trademark or Registered Trademark in conjunction with a work containing Open Game Content except as expressly licensed in another, independent Agreement with the owner of such Trademark or Registered Trademark. The use of any Product Identity in Open Game Content does not constitute a challenge to the ownership of that Product Identity. The owner of any Product Identity used in Open Game Content shall retain all rights, title and interest in and to that Product Identity.
8. Identification: If you distribute Open Game Content You must clearly indicate which portions of the work that you are distributing are Open Game Content.

9. Updating the License: Wizards or its designated Agents may publish updated versions of this License. You may use any authorized version of this License to copy, modify and distribute any Open Game Content originally distributed under any version of this License.

10 Copy of this License: You MUST include a copy of this License with every copy of the Open Game Content You Distribute.

11. Use of Contributor Credits: You may not market or advertise the Open Game Content using the name of any Contributor unless You have written permission from the Contributor to do so.

12 Inability to Comply: If it is impossible for You to comply with any of the terms of this License with respect to some or all of the Open Game Content due to statute, judicial order, or governmental regulation then You may not Use any Open Game Material so affected.

13 Termination: This License will terminate automatically if You fail to comply with all terms herein and fail to cure such breach within 30 days of becoming aware of the breach. All sublicenses shall survive the termination of this License.

14 Reformation: If any provision of this License is held to be unenforceable, such provision shall be reformed only to the extent necessary to make it enforceable.

15. COPYRIGHT NOTICE

Open Game License v 1.0a Copyright 2000, Wizards of the Coast, Inc.

System Reference Document Copyright 2000, Wizard of the Coast, Inc.; Authors Jonathan Tweet, Monte Cook, Skip Williams, based on original material by E. Gary Gygax and Dave Arneson.

Modern System Reference Document Copyright 2000, Wizards of the Coast, Inc.; Authors Bill Slavicsek, Jeff Grubb, Rich Redman, Charles Ryan, based on material by Jonathan Tweet, Monte Cook, Skip Williams, Richard Baker, Peter Adkison, Bruce R. Cordell, John Tynes, Andy Collins, and JD Wiker.

Knowledge (Current Events) Copyright 2004, Roger Carbol.

'd20 System' and the 'd20 System' logo are trademarks of Wizards of the Coast, Inc. and are used according to the terms of the d20 System License version 6.0. A copy of this License can be found at www.wizards.com/d20.

Dungeons & Dragons, Player's Handbook, d20 Modern, Psionics Handbook, Urban Arcana, and Wizards of the Coast are trademarks of Wizards of the Coast, Inc. in the United States and other countries and are used with permission.

Requires the use of a Roleplaying Game Core Book published by Wizards of the Coast, Inc.