

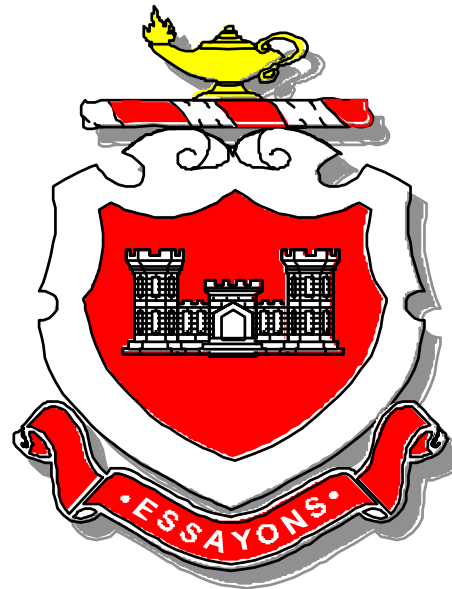

# ELECTRICIAN COURSE

---

## LESSON: INSTALL CABLE AND CONDUIT SYSTEMS



**LESSON NUMBER: 051-51R1-D06**



# INSTALL CABLE AND CONDUIT SYSTEMS

---

## Terminal Learning Objective

**Action:** Install electrical boxes, cable, and conduit systems.

**Conditions:** At a training site, given FM 5-424, the National Electric Code (NEC) book, construction prints and drawings, an installed malfunctioning service panel, an electrician's tool kit, armored and nonmetallic sheathed cable, electrical boxes, cable connectors and straps, electrical metallic tubing (EMT) conduit and connectors, flexible nonmetallic tubing (ENT) conduit and connectors, flexible metal conduit and connectors, screws, staples, and antishorting bushings

**Standards:** Identify materials and methods used to install electrical boxes, and install and troubleshoot cable and conduit systems in accordance with (IAW) FM 5-424, the NEC and construction prints and drawings.



# INSTALL CABLE AND CONDUIT SYSTEMS

---

## Safety, Risk, and Environmental Concerns

### **Safety Requirements:**

Use handtools, power tools, and ladders in a safe manner. Ensure conductors are turned toward the box when not in use. When cutting BX cable, assure a minimum of 6" clearance between your free hand and the cutting edge of the hacksaw blade. Ensure materials are not damaged when removing from installation locations. Remove ID tags, watches, and rings during all hardware oriented training.

### **Risk Assessment Level:**

Low.

### **Environmental Considerations:**

None.



# IDENTIFY MATERIALS AND METHODS USED TO INSTALL ELECTRICAL BOXES, CABLE AND CONDUIT SYSTEMS

---

## Lesson Topics

- Electrical Boxes
- Electrical Conductors
- Straps and Staples
- Roughing-In and Finishing



# IDENTIFY MATERIALS AND METHODS USED TO INSTALL ELECTRICAL BOXES, CABLE AND CONDUIT SYSTEMS

## Electrical Boxes

### Extender Rings

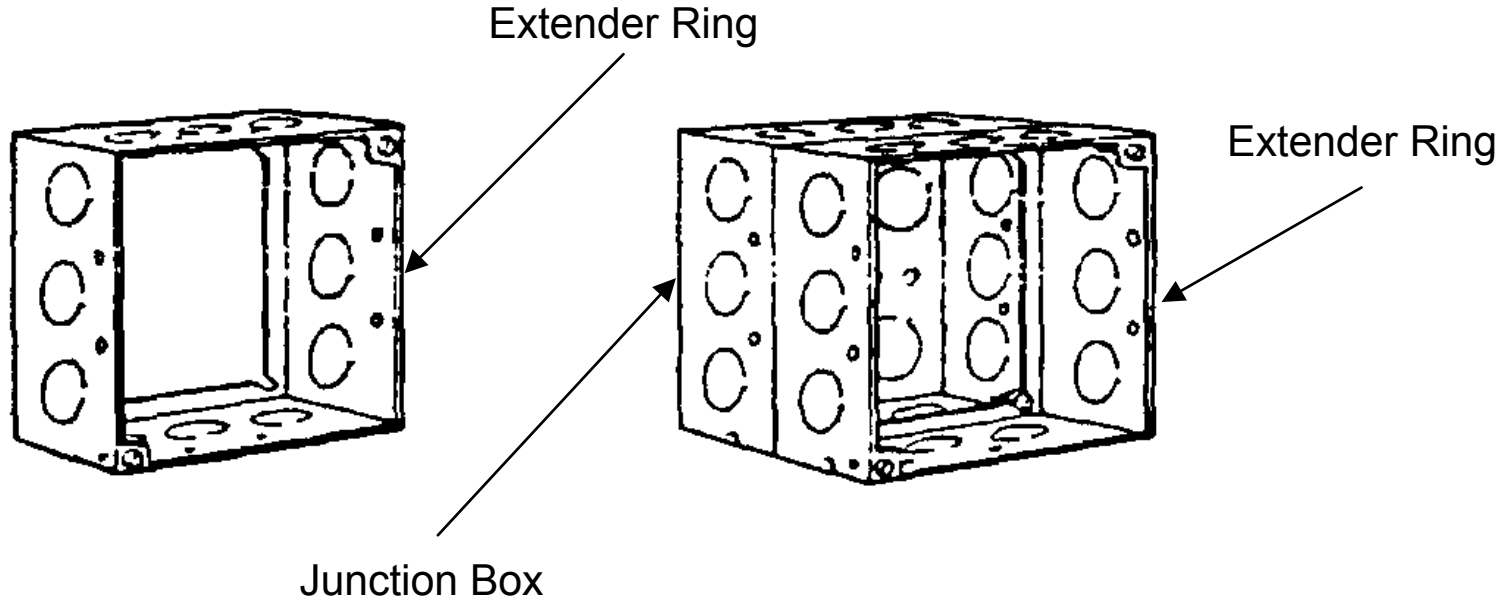



# IDENTIFY MATERIALS AND METHODS USED TO INSTALL ELECTRICAL BOXES, CABLE AND CONDUIT SYSTEMS

## Electrical Boxes

### Switch Boxes

For Concealed Wiring

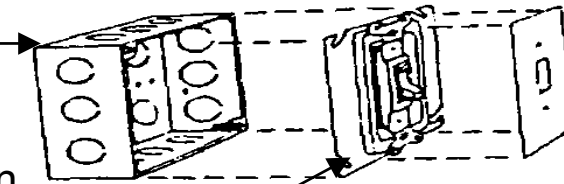

Switch Mounted on Plaster Ring

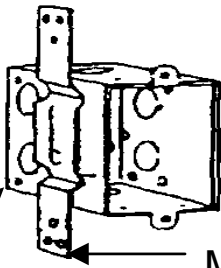

Metal Switch Box and Covers

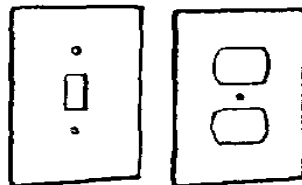

Mounting Bracket

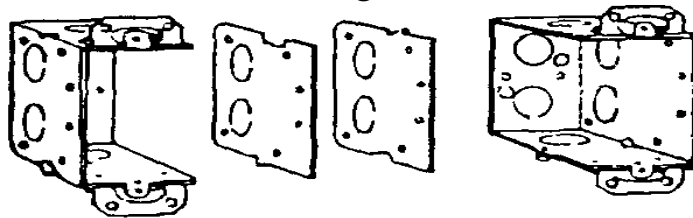

To Gang Boxes,  
Remove One Side From Each Box

Nonmetallic Switch and Receptacle Covers

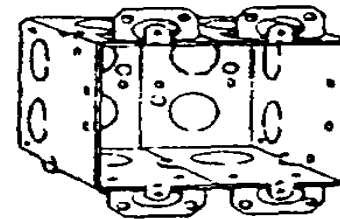
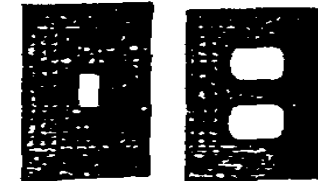

Screw Boxes Together



# IDENTIFY MATERIALS AND METHODS USED TO INSTALL ELECTRICAL BOXES, CABLE AND CONDUIT SYSTEMS

## Electrical Boxes

### Outlet Boxes

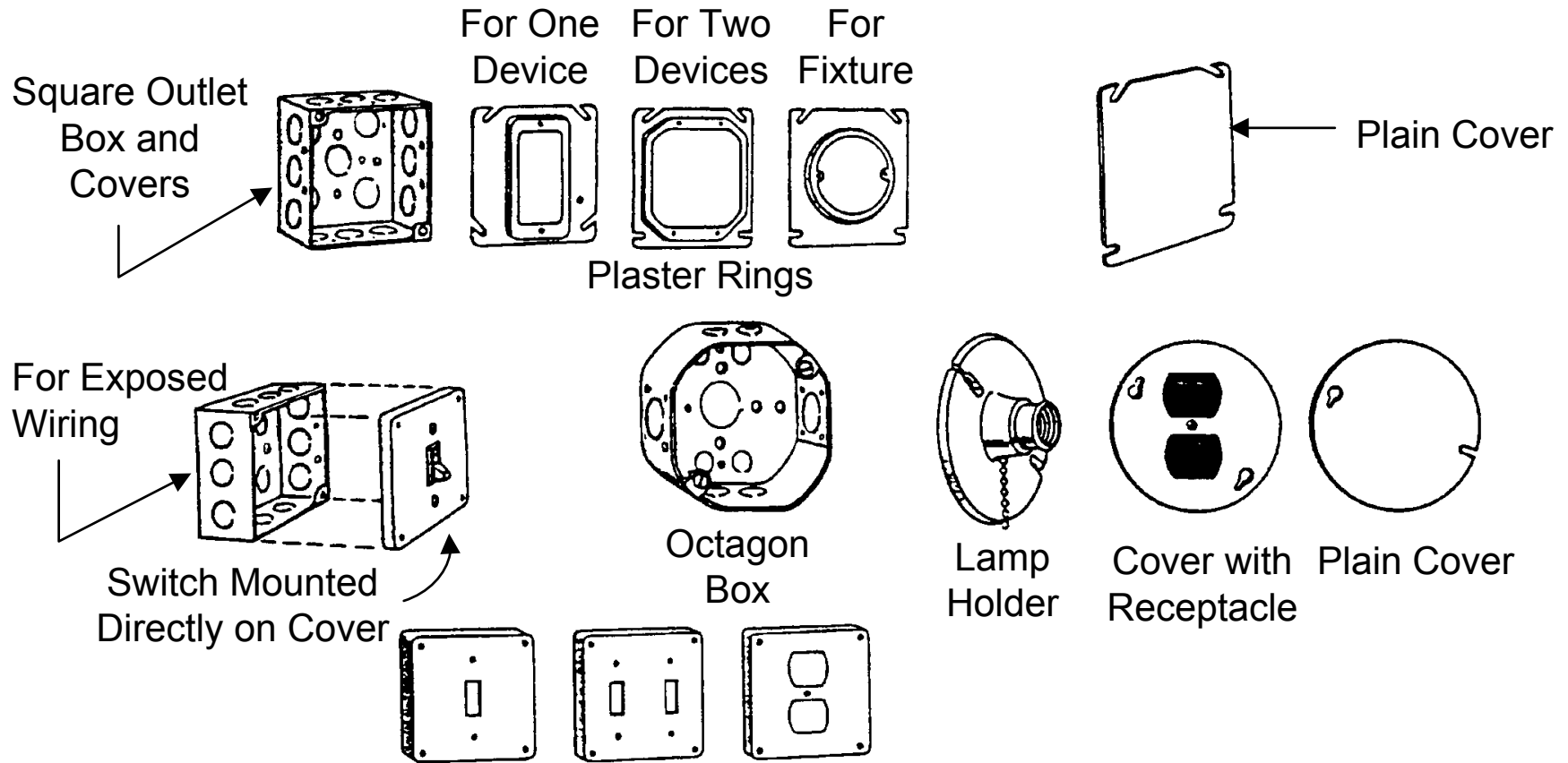



# IDENTIFY MATERIALS AND METHODS USED TO INSTALL ELECTRICAL BOXES, CABLE AND CONDUIT SYSTEMS

## Electrical Boxes

### Special Boxes

Outlet Box

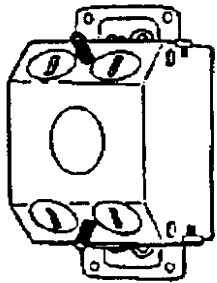

Weatherproof Box

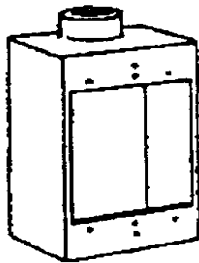

Gasket

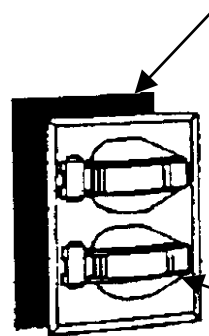

Weatherproof Receptacle Cover

Gasket

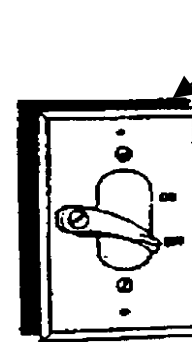

Weatherproof Switch Cover

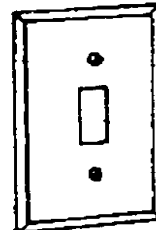
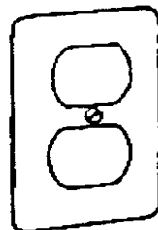
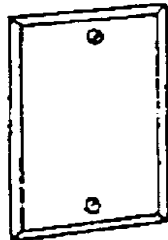
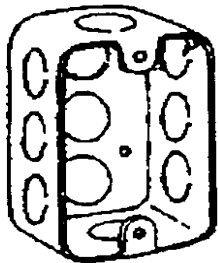

Utility or "Handy" Box and Covers

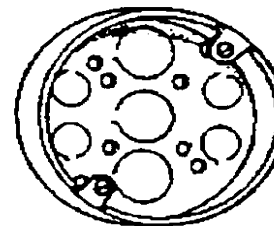

Pancake Box

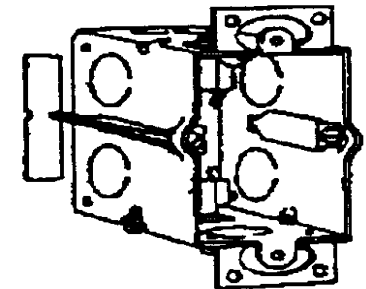

Device Box for Dry Wall Construction



# IDENTIFY MATERIALS AND METHODS USED TO INSTALL ELECTRICAL BOXES, CABLE AND CONDUIT SYSTEMS

## Electrical Boxes

### Typical Box Mountings

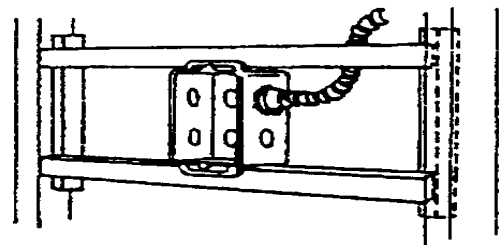

Wooden Cleats

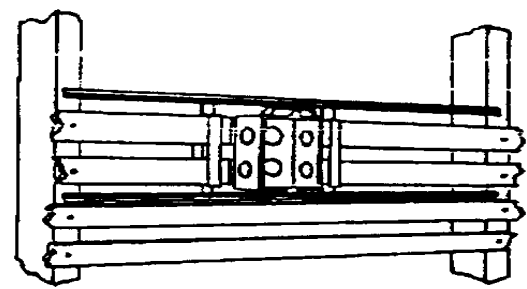

Mounting Straps

Support "on edge" against the rear face of the sheetrock.

Mounting Bar

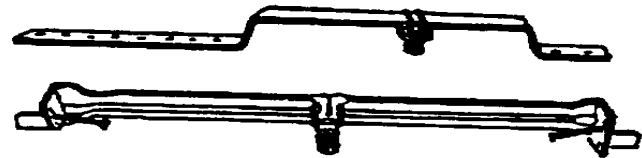

Bar Hangers

Sheetrock (drywall) or plaster on plasterboard.

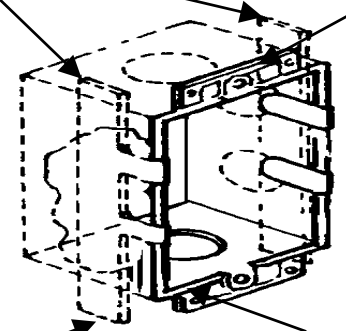

Outlet Box

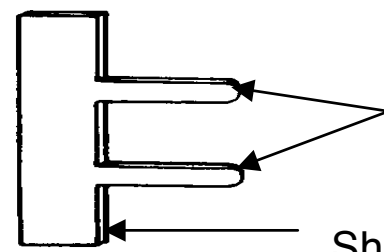

Fins

Sheet Metal Stamping



# IDENTIFY MATERIALS AND METHODS USED TO INSTALL ELECTRICAL BOXES, CABLE AND CONDUIT SYSTEMS

## Straps and Staples

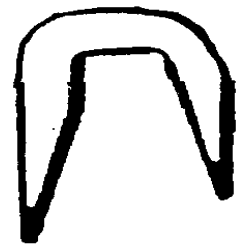

Cable Staple



Insulated Staple

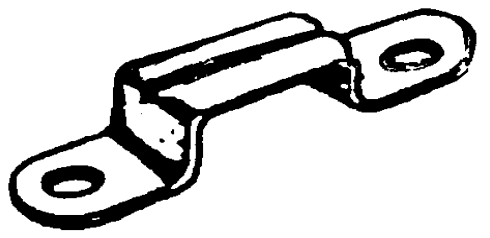

Nonmetallic Cable Strap



Conduit/Cable Full Strap

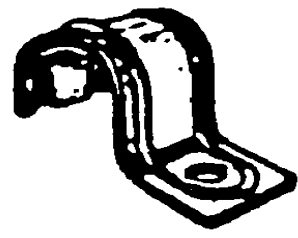

Conduit/Cable Half Strap



# IDENTIFY MATERIALS AND METHODS USED TO INSTALL ELECTRICAL BOXES, CABLE AND CONDUIT SYSTEMS

## Roughing-In and Finishing

### Ceiling Mounted Light

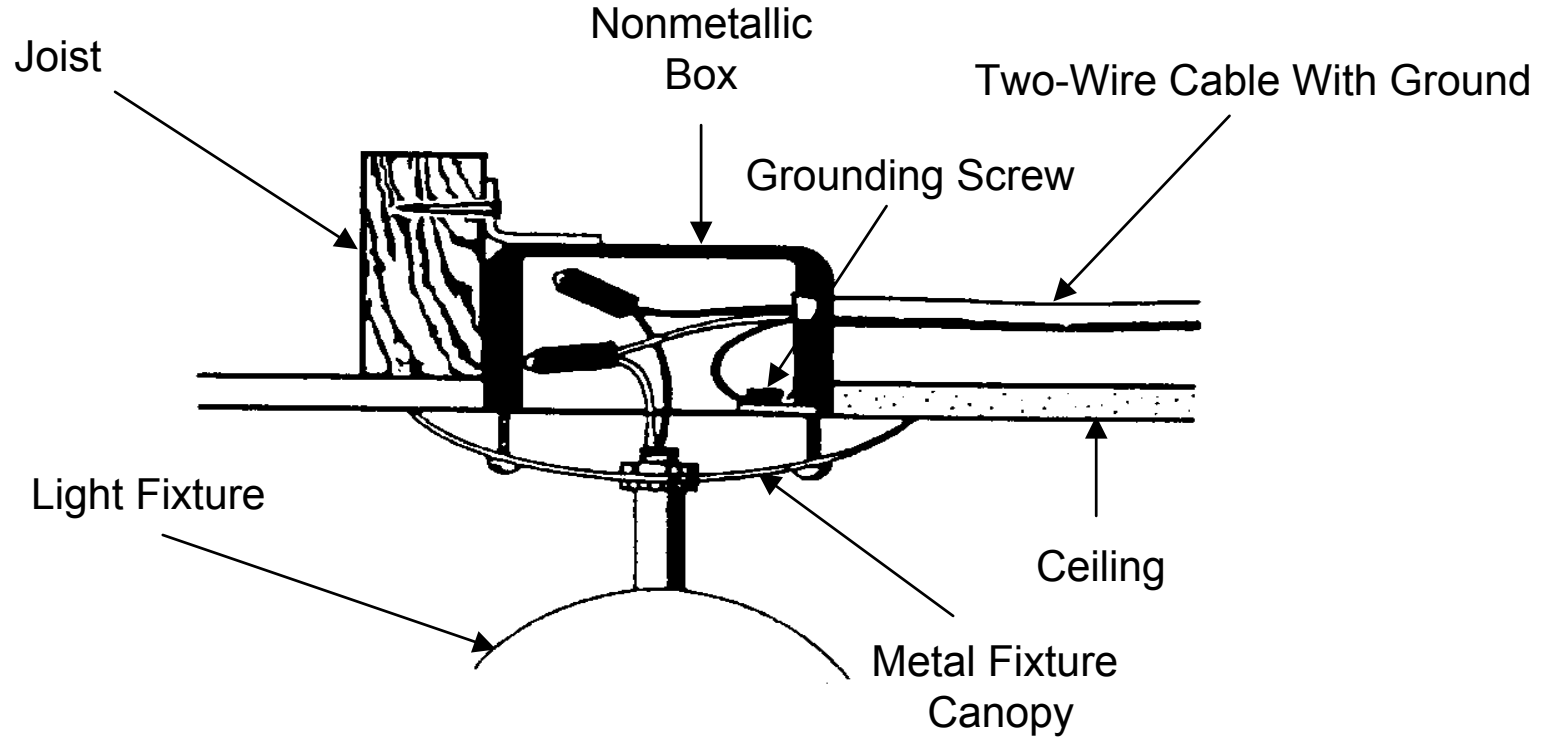



# INSTALL ELECTRICAL BOXES AND A CABLE SYSTEM

---

## Lesson Topics

- Characteristics of Armored Cable Wiring
- Armored Cable Wiring Materials
- Installation of Armored Cable Systems
- Characteristics of Nonmetallic-Sheathed Cable Wiring
- Nonmetallic-Sheathed Cable Wiring Materials
- Installation of Nonmetallic-Sheathed Cable Wiring
- Installing Electrical Boxes and Cable Systems



# INSTALL ELECTRICAL BOXES AND A CABLE SYSTEM

## Installation of Armored Cable Systems

### Armored Cable Bend

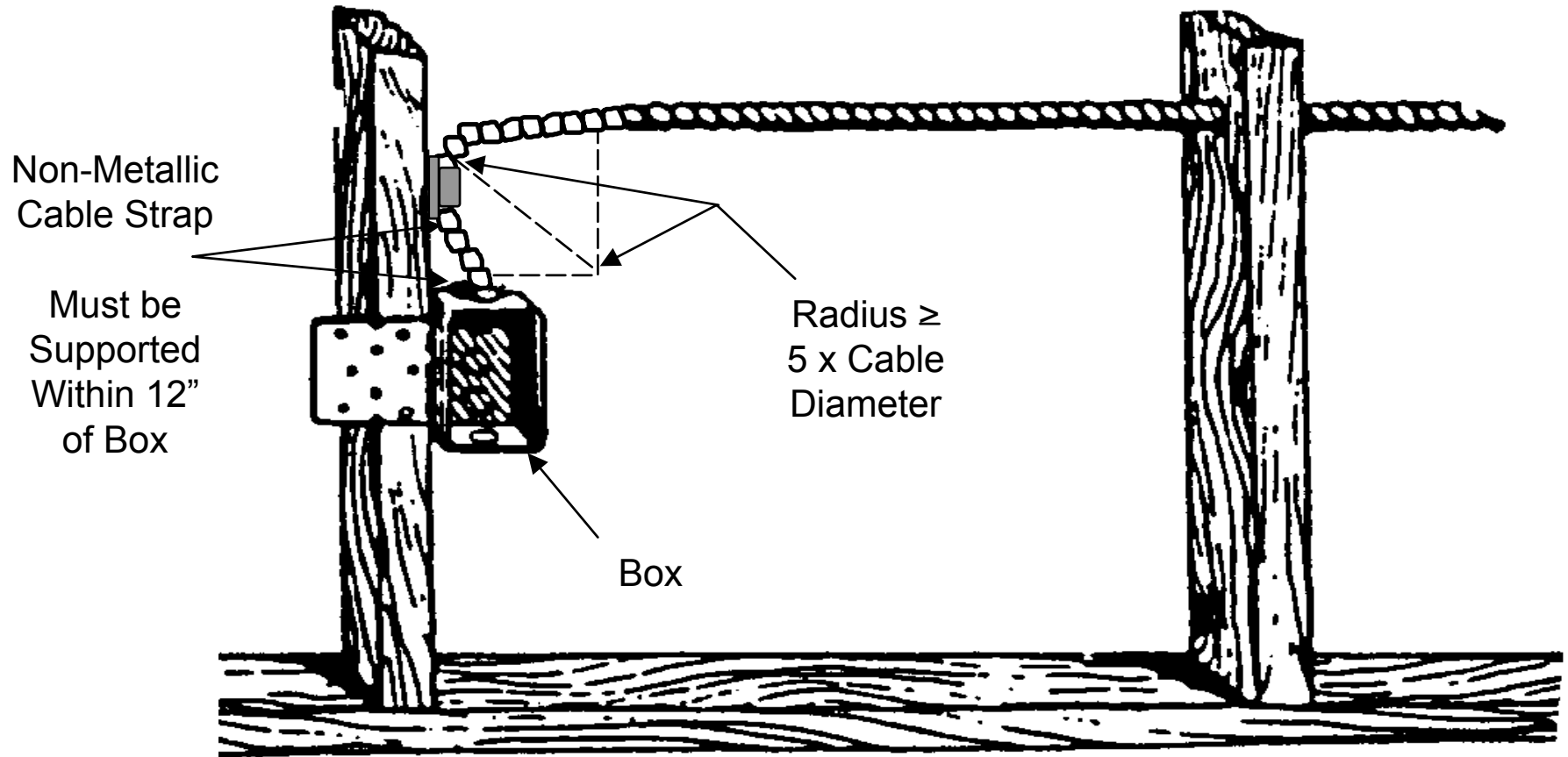



# INSTALL ELECTRICAL BOXES AND A CABLE SYSTEM

## Installation of Armored Cable Systems

### Cutting and Attaching Cable

Cutting cable with a hacksaw.

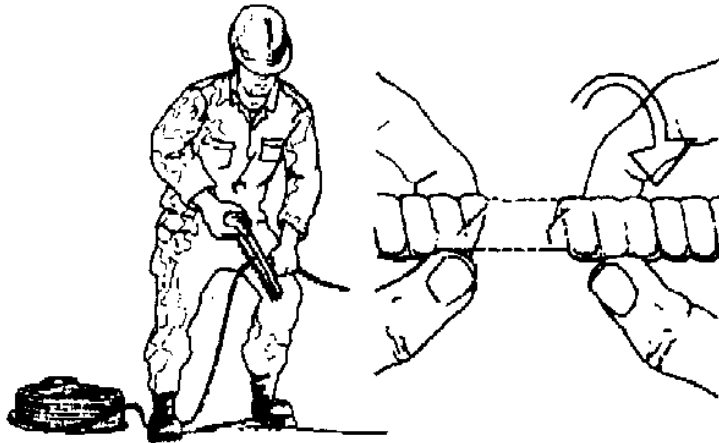

Note that the armor  
is cut at an angle  
to the lay.

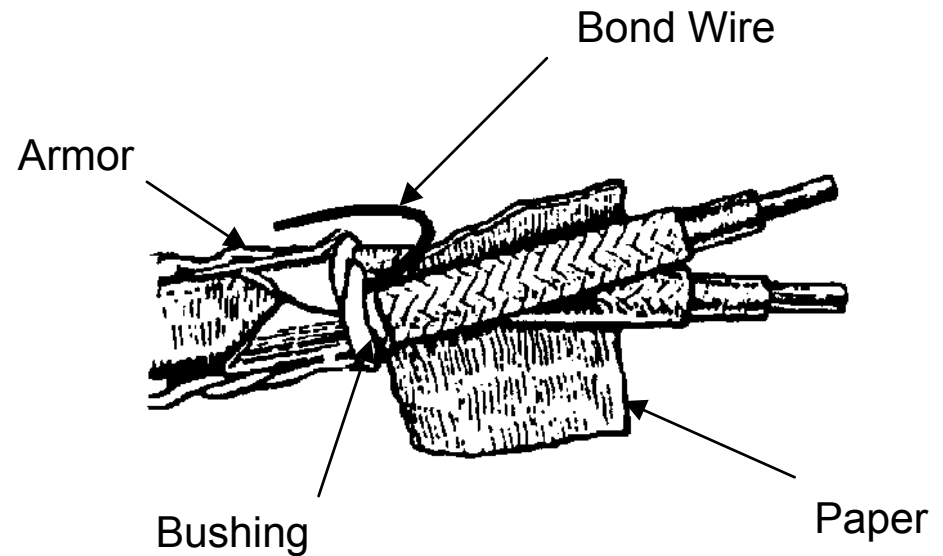



# INSTALL ELECTRICAL BOXES AND A CABLE SYSTEM

## Installation of Armored Cable Systems

### Cable Connection to Box

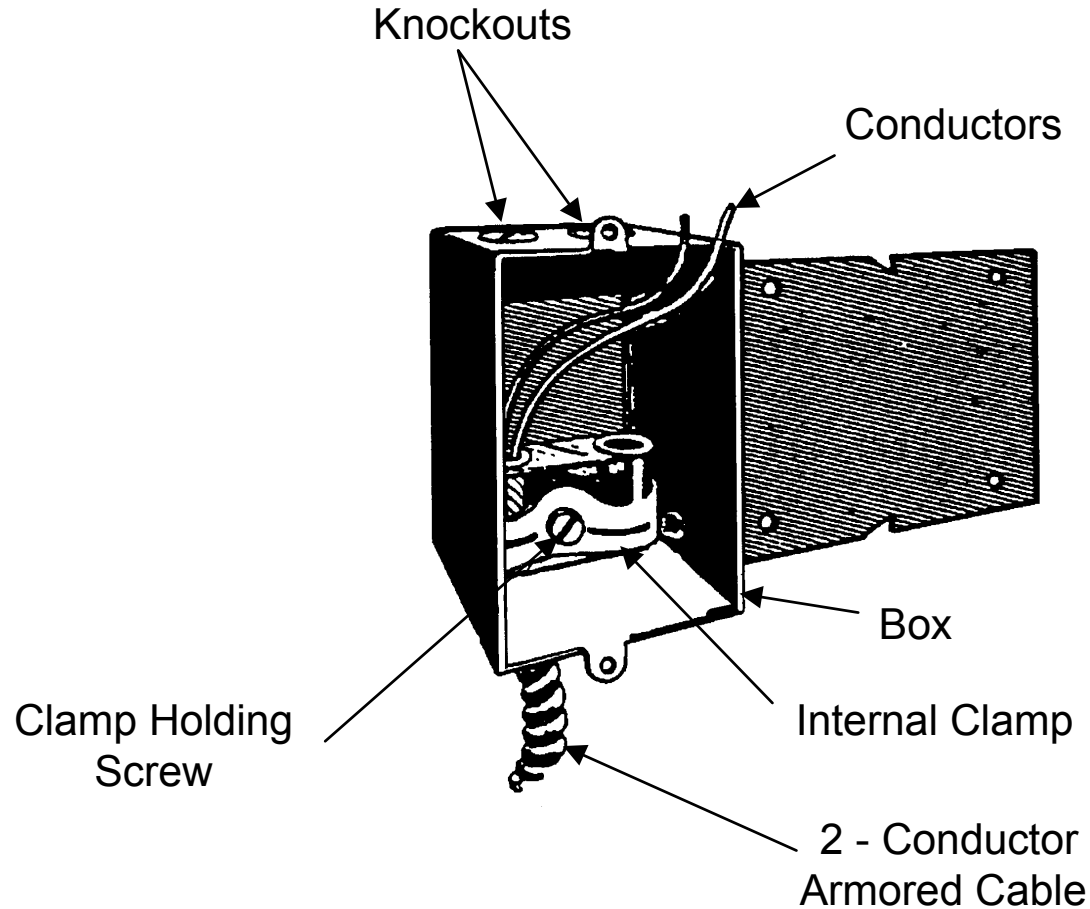



# INSTALL ELECTRICAL BOXES AND A CABLE SYSTEM

## Nonmetallic-Sheathed Cable Wiring Materials

### Installing a Grounding Clip

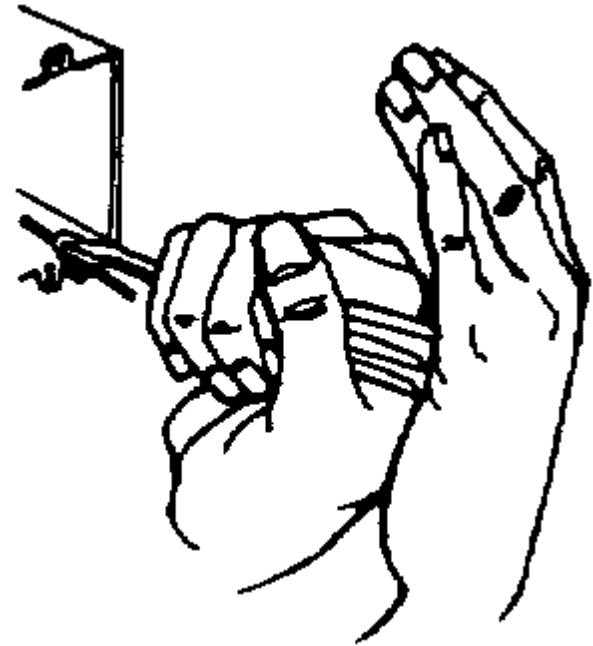
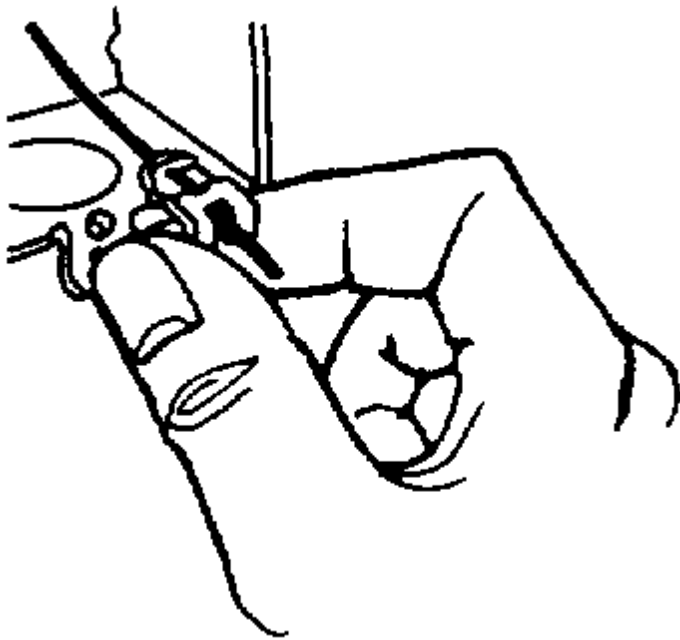



# INSTALL ELECTRICAL BOXES AND A CABLE SYSTEM

## Installation of Nonmetallic-Sheathed Cable Wiring

### Removal of Sheathing

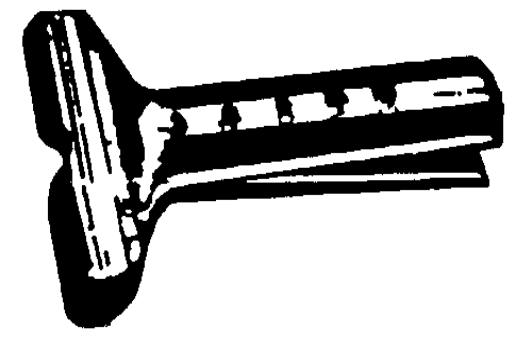
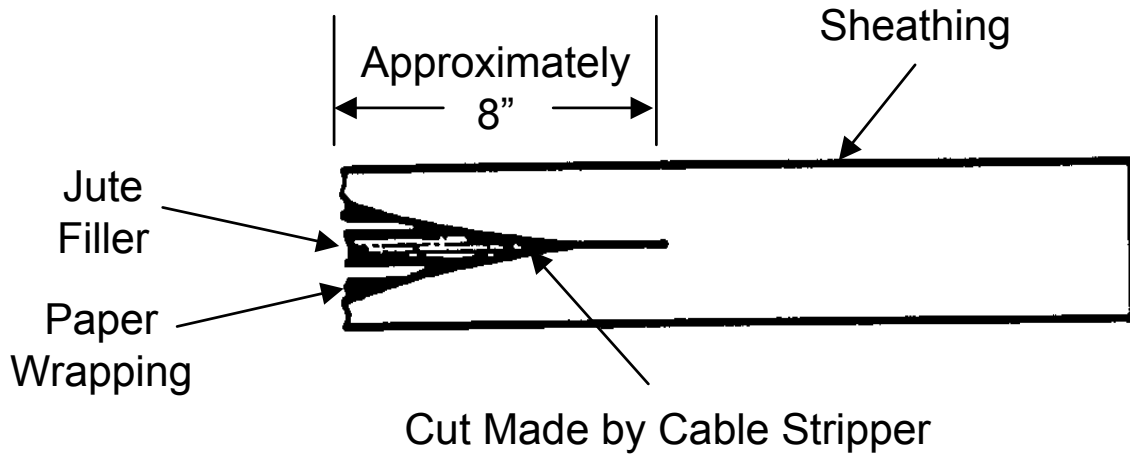

### Slitting of Cable

Cable Stripper



# INSTALL ELECTRICAL BOXES AND A CABLE SYSTEM

---

## Lesson Topics

- Rigid Conduit
- Electrical Metal Tubing (EMT)
- Flexible Metal and Nonmetallic Conduit
- Installation of Electrical Boxes
- Installation of Electrical Metal Tubing (EMT)
- Installation of Flexible Metal Conduit
- Installation of Flexible Nonmetallic Conduit



# INSTALL ELECTRICAL BOXES AND A CABLE SYSTEM

## Rigid Conduit

### Fittings

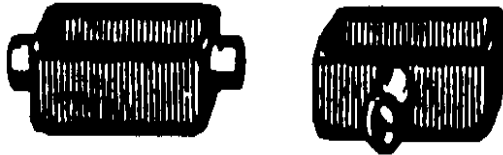

LL

LB

T

### Condulets



Locknut



Bushing

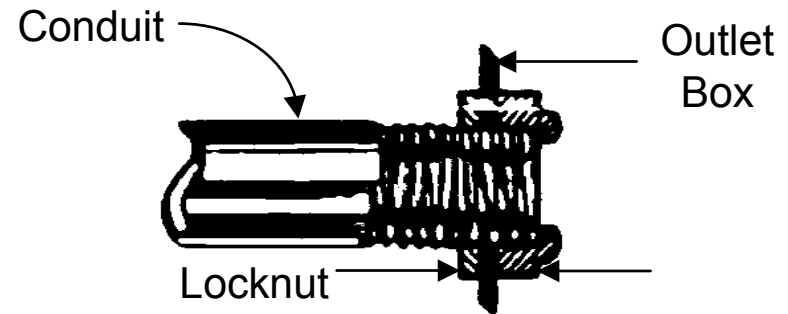

### Dead-End Conduit in Outlet Box



# INSTALL ELECTRICAL BOXES AND A CABLE SYSTEM

## Rigid Conduit

### Bending

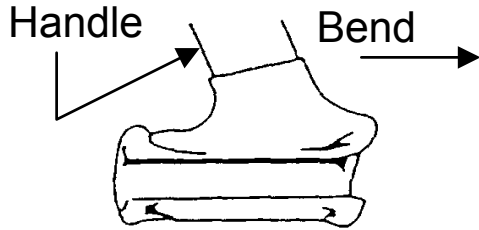

Factory Made Head  
For Hickey

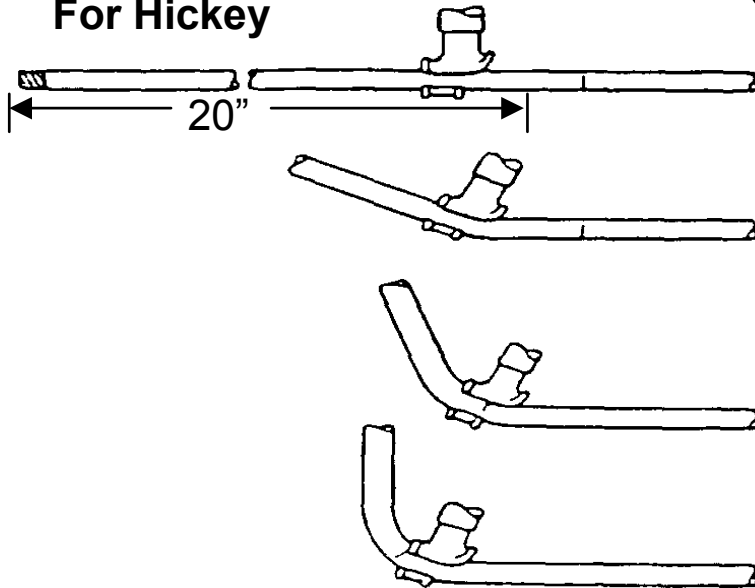

### EMT Bender

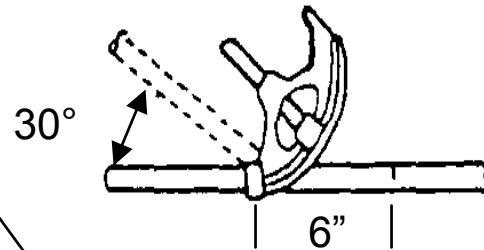

Place Arrow Opposite  
Your Marks

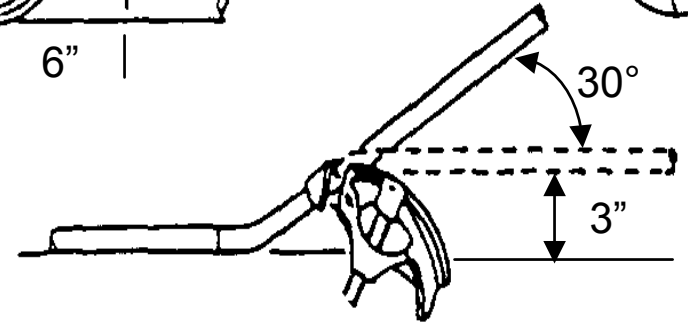

### Offset Bend



# INSTALL ELECTRICAL BOXES AND A CABLE SYSTEM

## Rigid Conduit

### Attachment of Fishwire

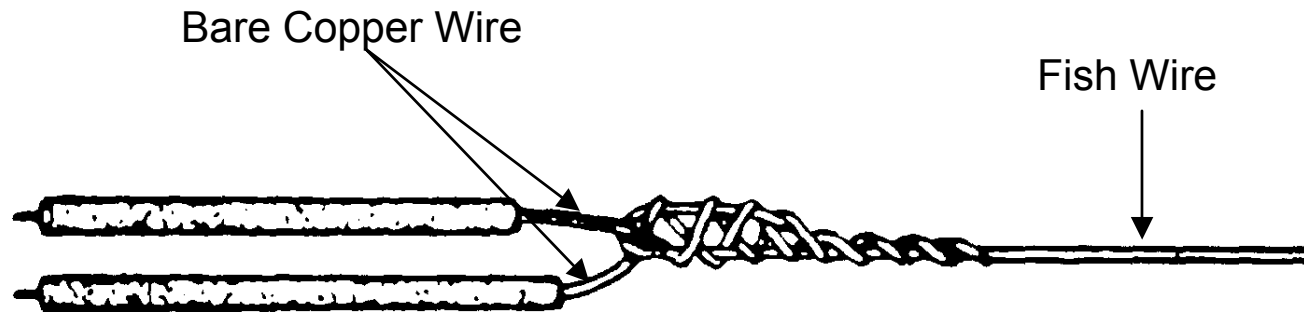

### Attachment of Standard Conductor to Tape

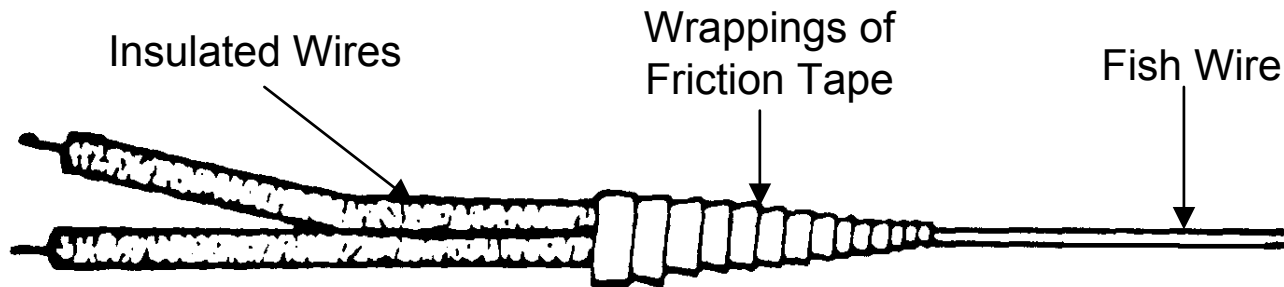

### Attachment Taped Over



# INSTALL ELECTRICAL BOXES AND A CABLE SYSTEM

## EMT Conduit

### Fittings

#### Inside Structure

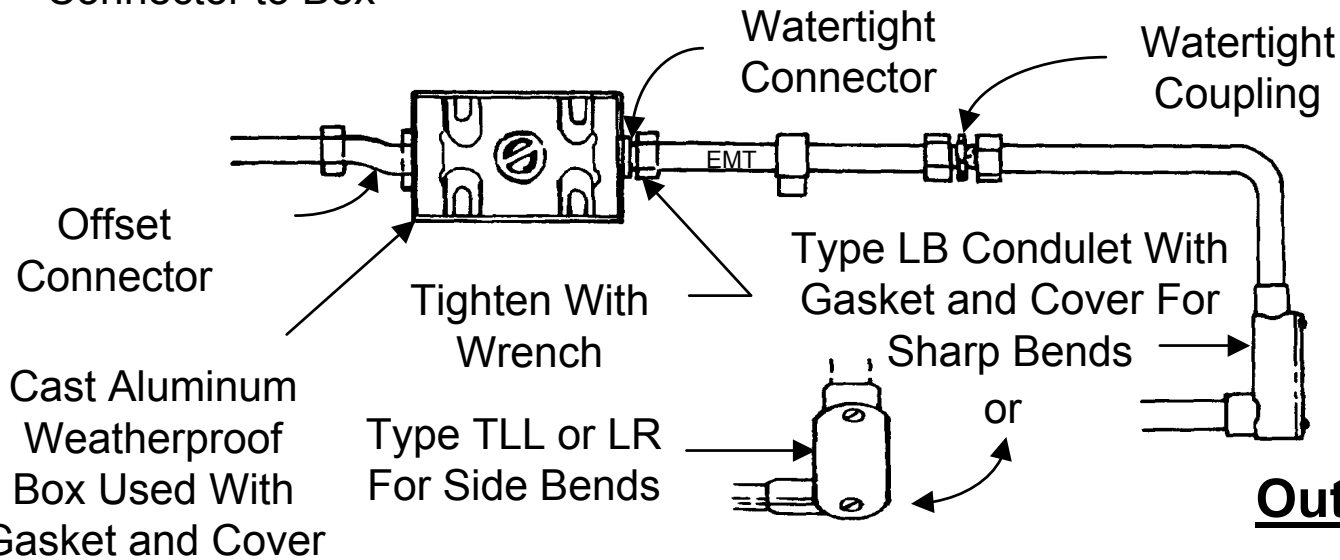
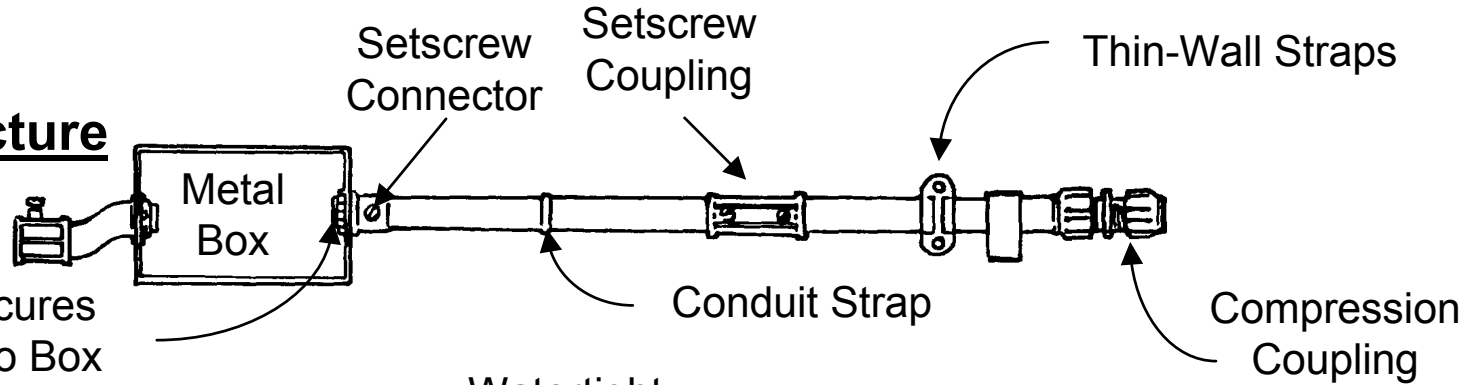

#### Outside Structure



# INSTALL ELECTRICAL BOXES AND A CABLE SYSTEM

## EMT Bender

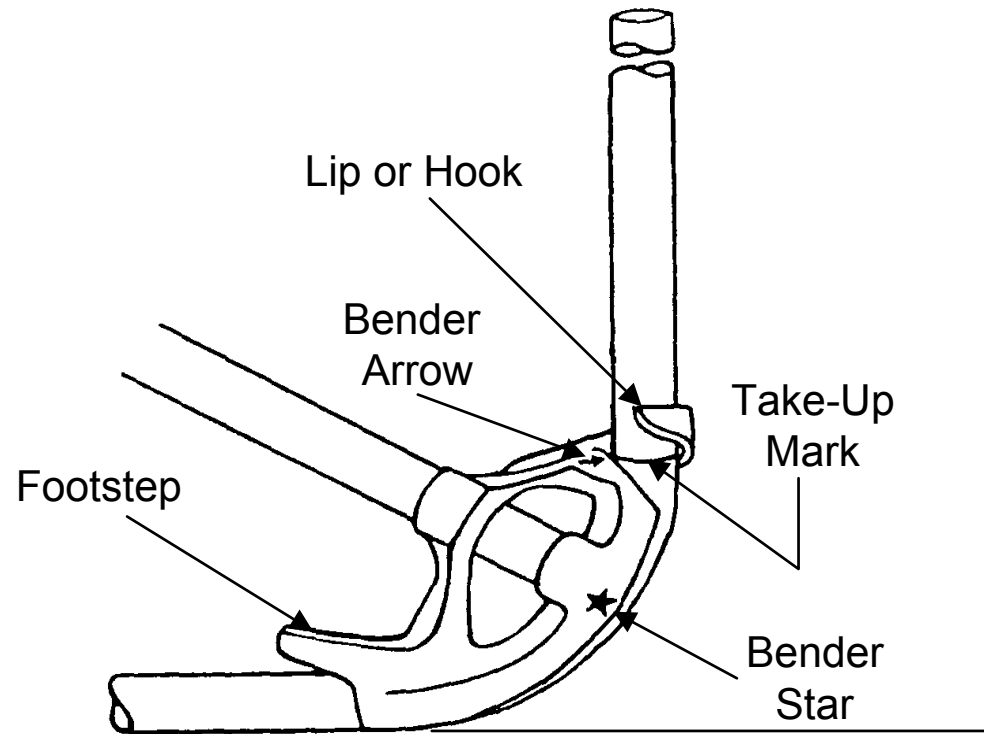



# INSTALL ELECTRICAL BOXES AND A CONDUIT SYSTEM

## Electrical Metal Tubing (EMT)

Reference Point

Ceiling

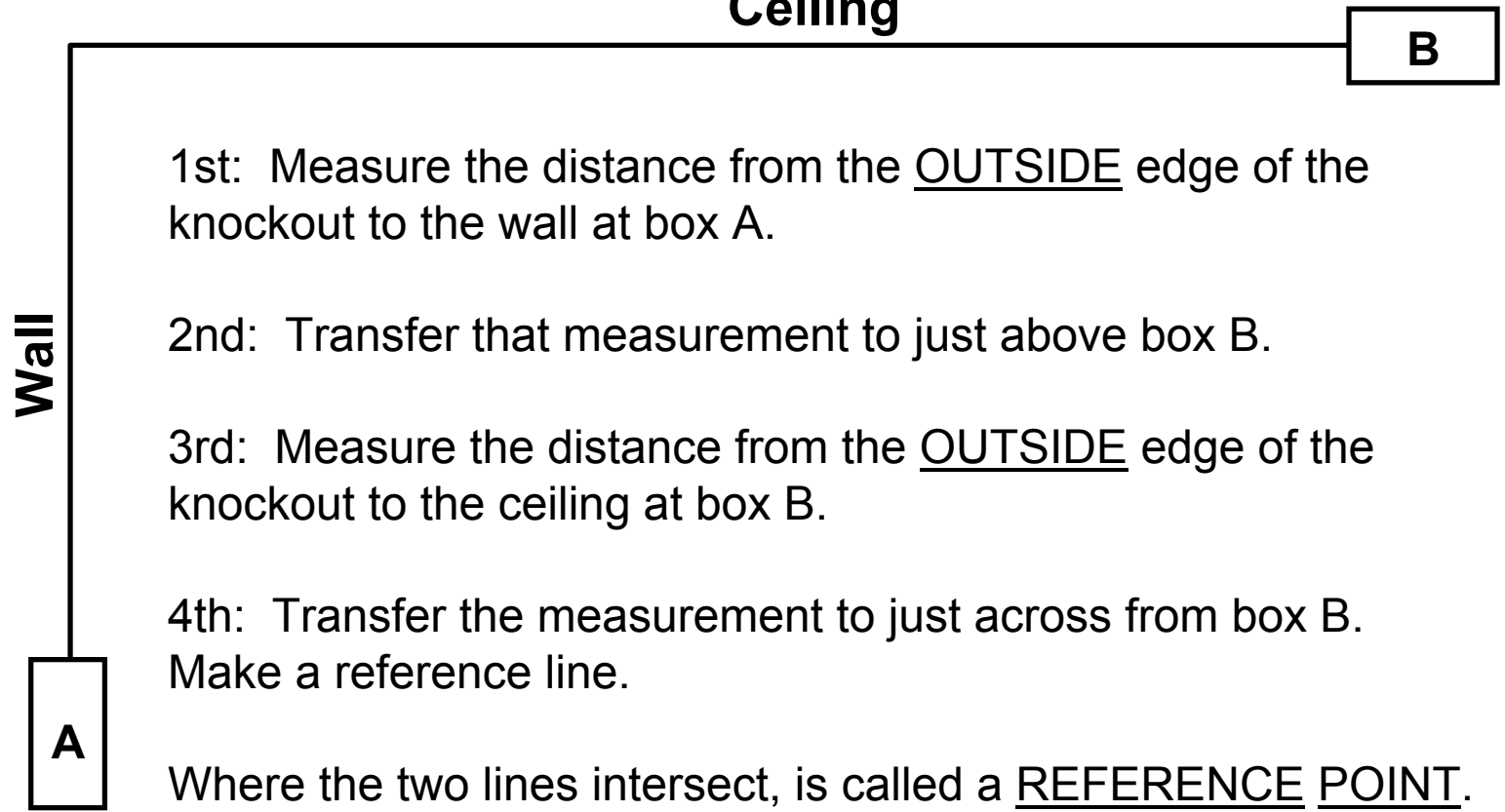

1st: Measure the distance from the OUTSIDE edge of the knockout to the wall at box A.

2nd: Transfer that measurement to just above box B.

3rd: Measure the distance from the OUTSIDE edge of the knockout to the ceiling at box B.

4th: Transfer the measurement to just across from box B. Make a reference line.

Where the two lines intersect, is called a REFERENCE POINT.



# INSTALL ELECTRICAL BOXES AND A CONDUIT SYSTEM

## Electrical Metal Tubing (EMT)

### Conduit Gain

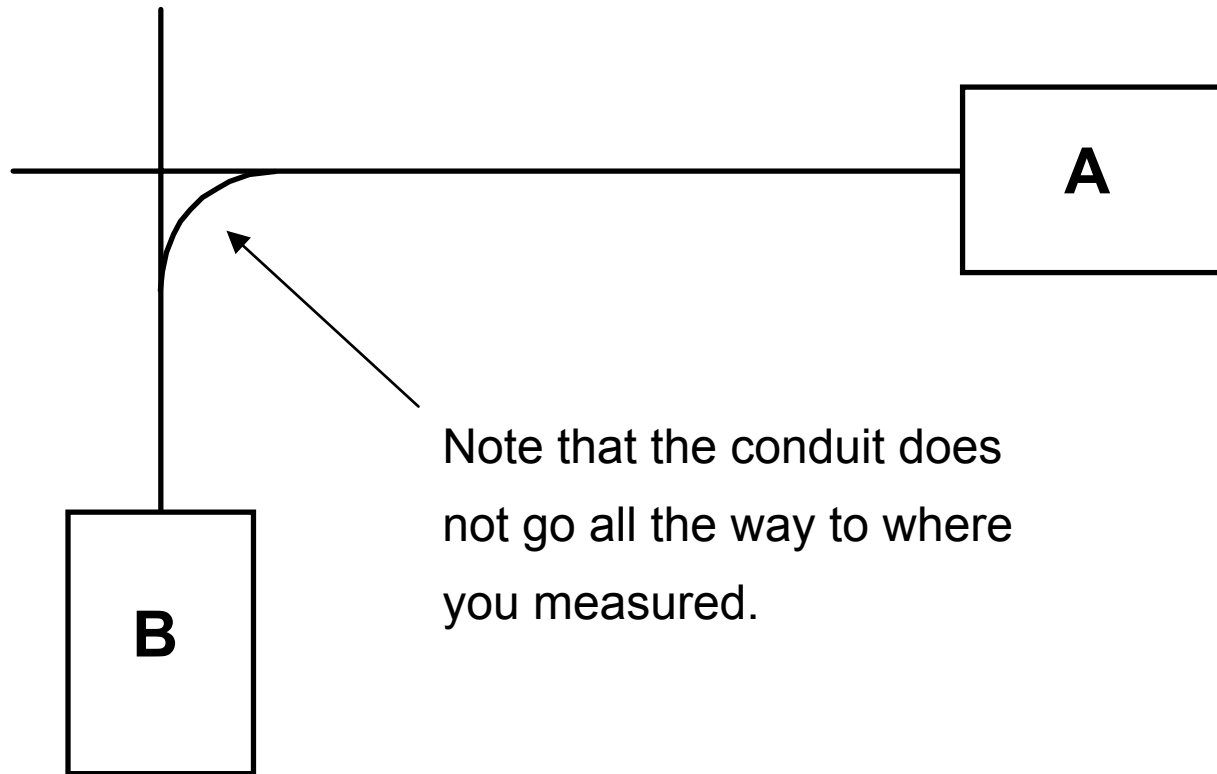

Note that the conduit does not go all the way to where you measured.



# INSTALL ELECTRICAL BOXES AND A CONDUIT SYSTEM

## Electrical Metal Tubing (EMT)

### Bender Gain Table

#### BENDER "GAIN" TABLE

Conduit Type/Size	90 Degree "GAIN"
1/2" EMT	2 5/8"
3/4" EMT 1/2" Rigid	3 1/4"
1" EMT 3/4" Rigid	1"
1 1/4" EMT 1" Rigid	5 5/8"



# INSTALL ELECTRICAL BOXES AND A CONDUIT SYSTEM

## Electrical Metal Tubing (EMT)

### Conduit Take-Up

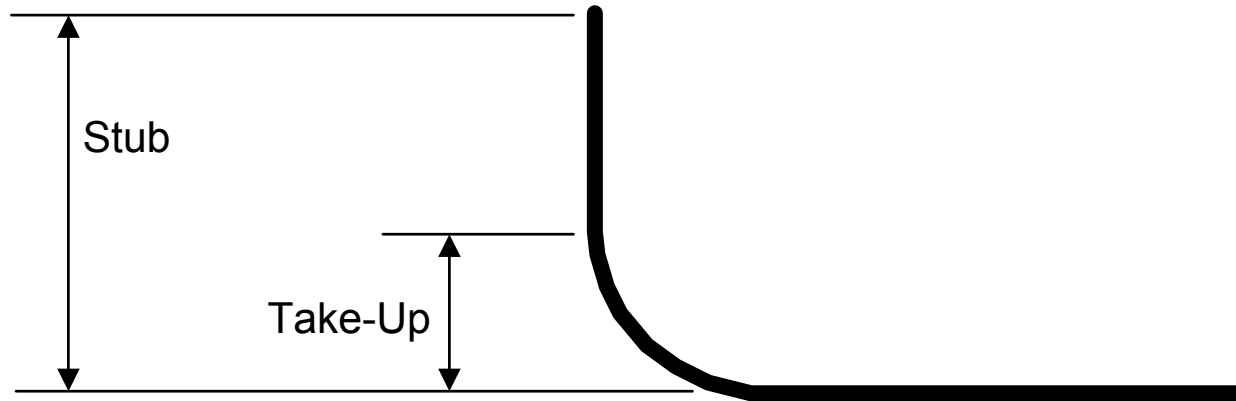



# INSTALL ELECTRICAL BOXES AND A CONDUIT SYSTEM

## Electrical Metal Tubing (EMT)

### Conduit Take-Up Table

CONDUIT TAKE-UP TABLE  
Amount of Take-Up for 90 Degree Bends

Size and Type of Conduit	Take-Up
1/2" EMT	6"
3/4" EMT 1/2" Rigid	6"
1" EMT 3/4" Rigid	8"
1 1/4" EMT 1" Rigid	11"



# INSTALL ELECTRICAL BOXES AND A CONDUIT SYSTEM

## Electrical Metal Tubing (EMT)

### Back to Back Bend

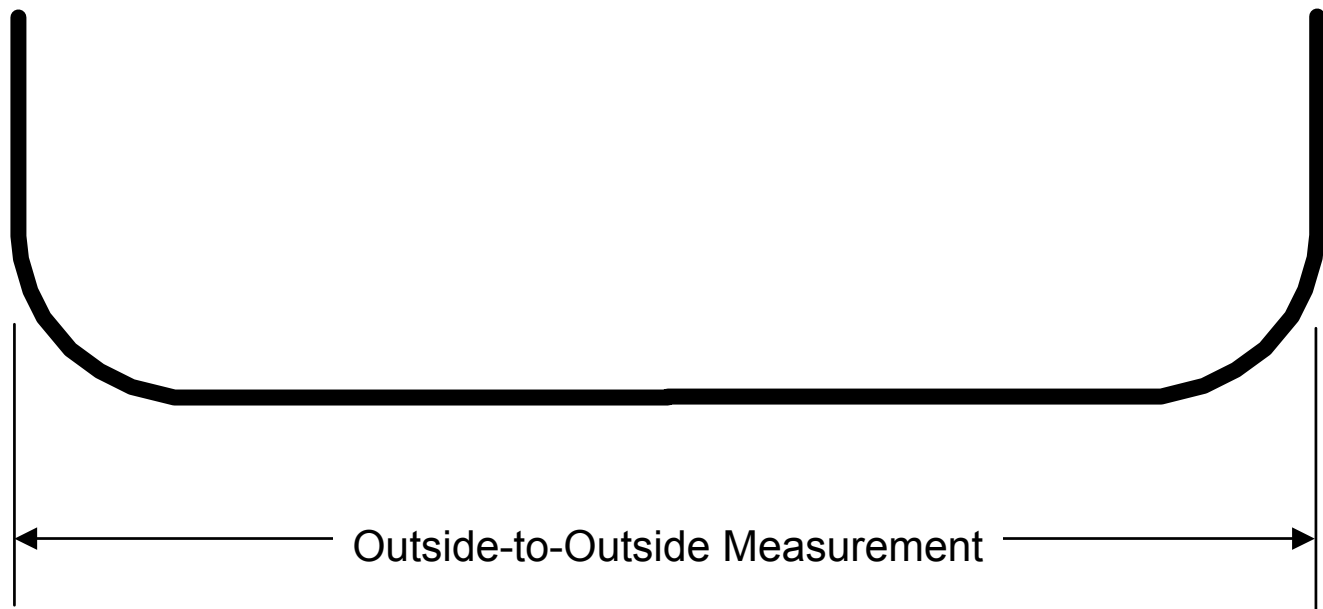



# INSTALL ELECTRICAL BOXES AND A CONDUIT SYSTEM

## Electrical Metal Tubing (EMT)

### Offset Bend

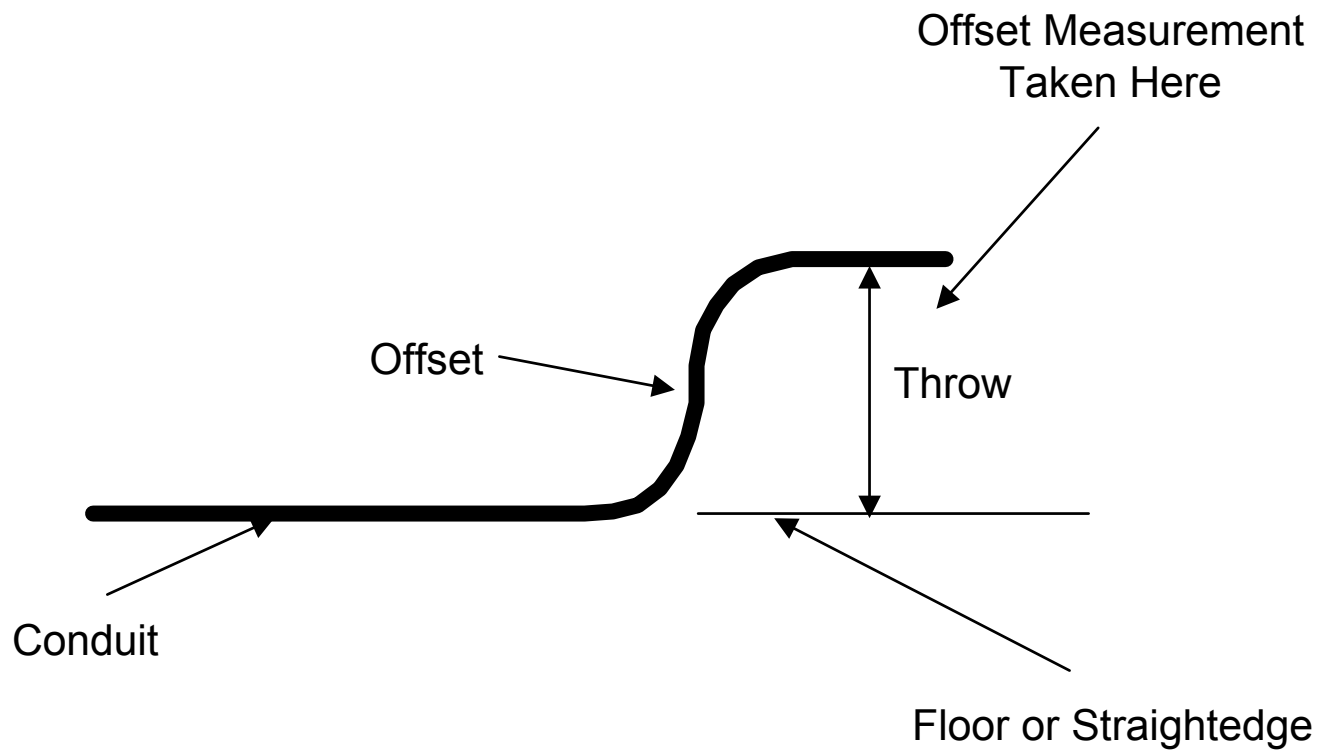



# INSTALL ELECTRICAL BOXES AND A CONDUIT SYSTEM

## Electrical Metal Tubing (EMT)

### Offset Measurements

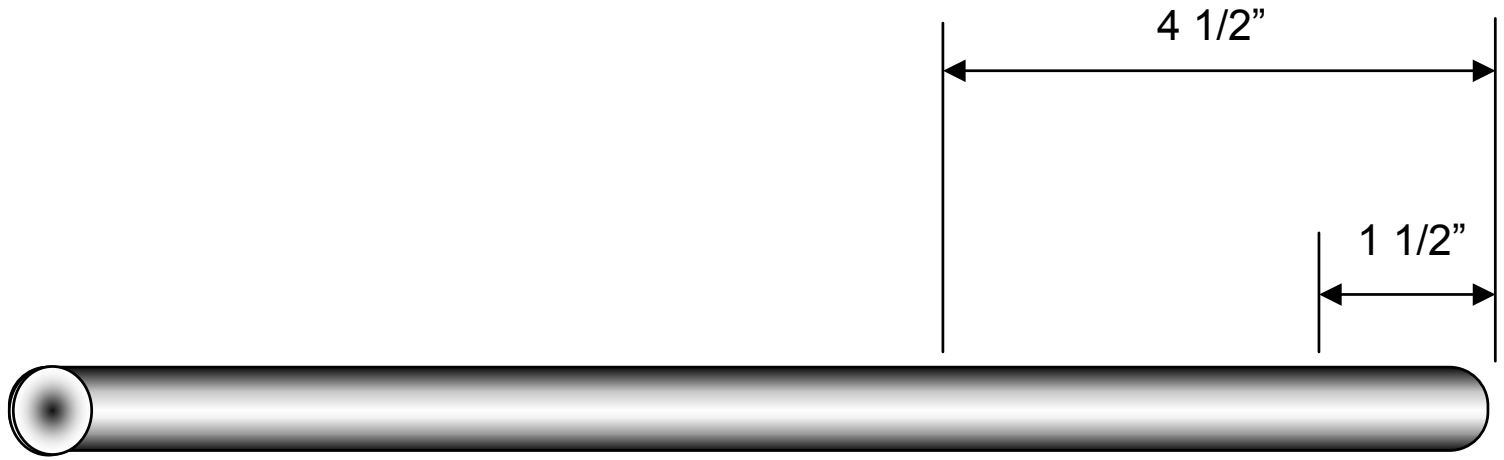



# INSTALL ELECTRICAL BOXES AND A CONDUIT SYSTEM

## Electrical Metal Tubing (EMT)

### Offset Bend Formula

OFFSET BENDING FORMULA  
Formula and Constant Multiplier For Determining Distance  
Between Bends When Bending Offsets

OFFSET DEPTH X CONSTANT MULTIPLIER = DISTANCE BETWEEN BENDS

DEGREE ANGLE OF BENDS

CONSTANT MULTIPLIER

	2.5
22 1/2 X 22 1/2	2.5
30 X 50	2.0
45 X 45	1.5
60 X 60	1.2



# INSTALL ELECTRICAL BOXES AND A CONDUIT SYSTEM

## Electrical Metal Tubing (EMT)

### Bend Marks

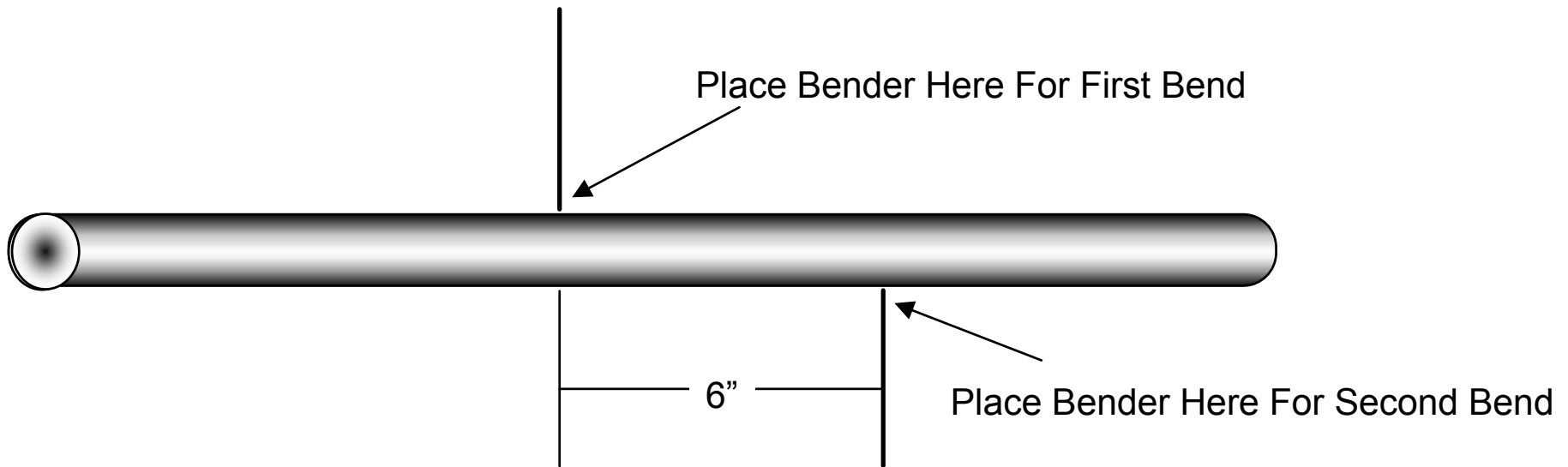



# INSTALL ELECTRICAL BOXES AND A CABLE SYSTEM

## Flexible Metal and Nonmetallic Conduits

### Flexible Conduit

90° Clamp

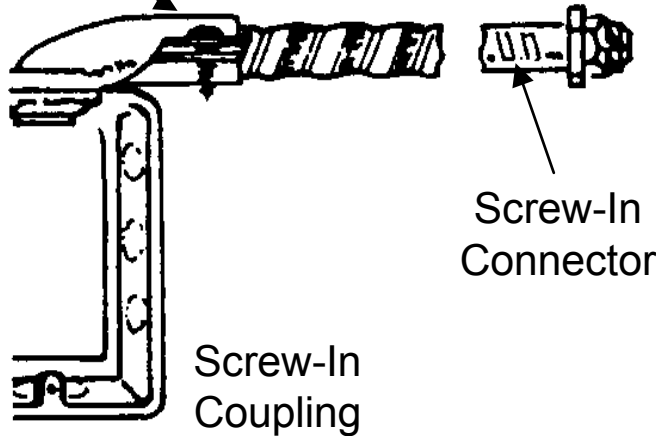

Screw-In  
Connector

Screw-In  
Coupling

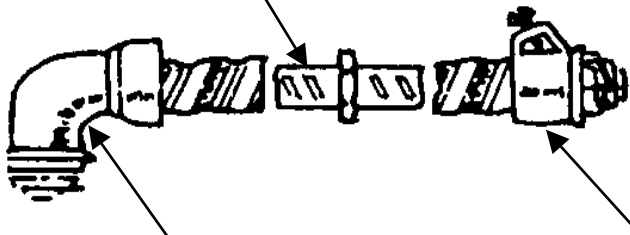

90° Screw-In  
Connector

Straight Setscrew  
Clamp

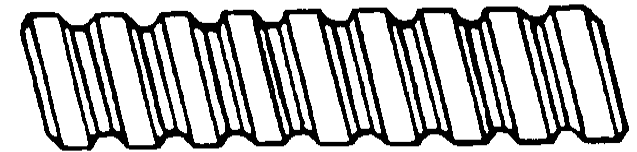

Size in Inches	
Steel	Aluminum
5/16	3/8
3/8	1/2
1/2	3/4
3/4	1
1	1 1/4
1 1/4	1 1/2
1 1/2	2
2	2 1/2
2 1/2	3
3	3 1/2
	4



# INSTALL ELECTRICAL BOXES AND A CABLE SYSTEM

## Flexible Metal and Nonmetallic Conduits

### Conduit Fittings

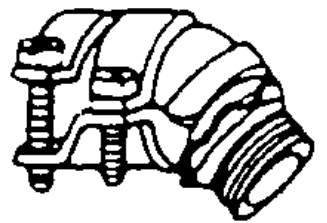
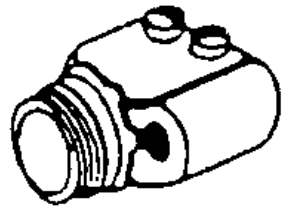



# TROUBLESHOOT MALFUNCTIONS IN ELECTRICAL CIRCUITS

---

## Lesson Topics

- Troubleshooting an Electrical Circuit
- Circuit Testing



# TROUBLESHOOT MALFUNCTIONS IN ELECTRICAL CIRCUITS

## Troubleshooting an Electrical Circuit

### Short Circuits

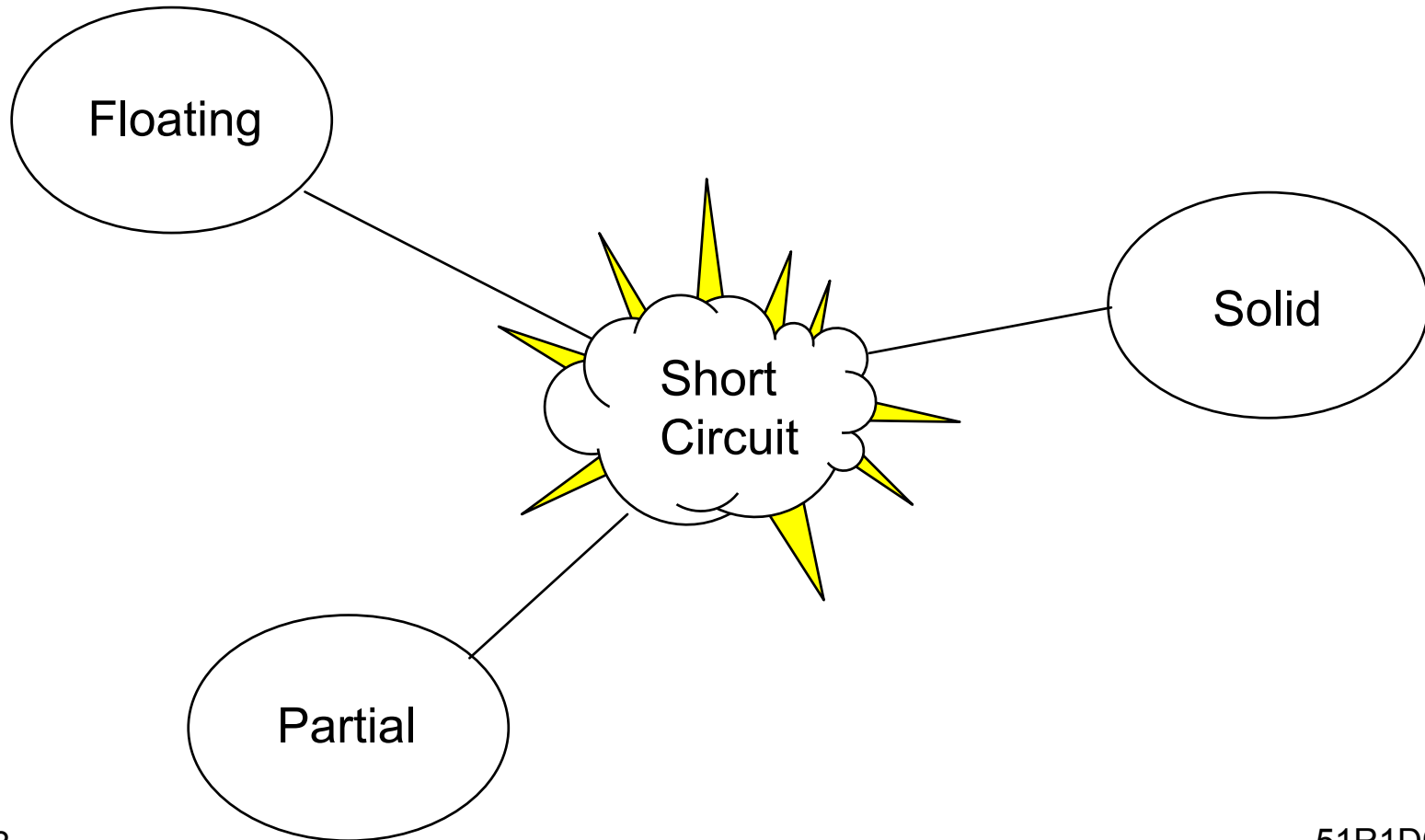



# TROUBLESHOOT MALFUNCTIONS IN ELECTRICAL CIRCUITS

## Troubleshooting an Electrical Circuit

### Neon Tester

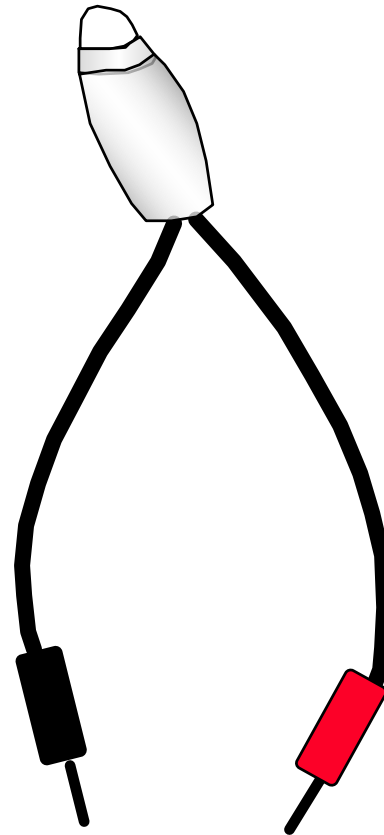



# TROUBLESHOOT MALFUNCTIONS IN ELECTRICAL CIRCUITS

## Troubleshooting an Electrical Circuit

### Continuity Tester

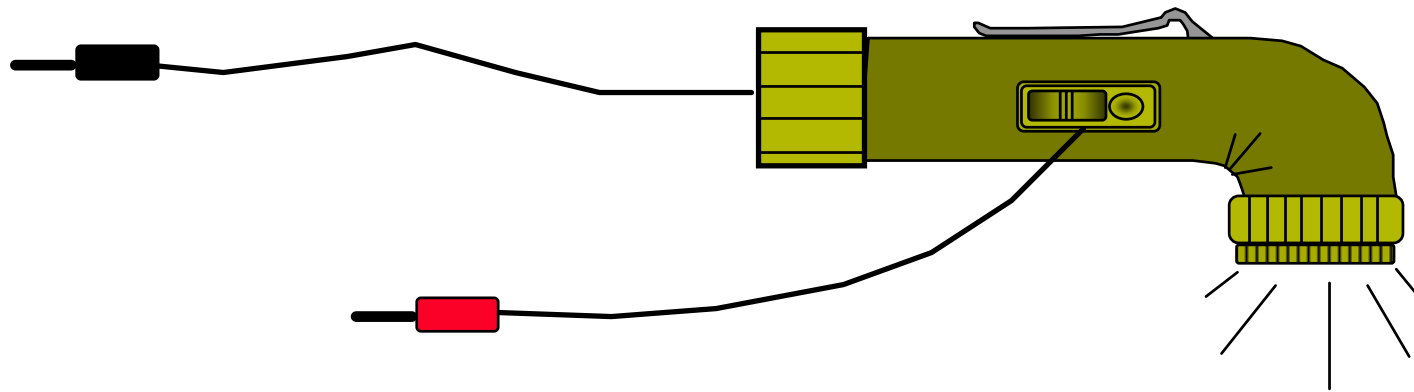



# TROUBLESHOOT MALFUNCTIONS IN ELECTRICAL CIRCUITS

## Troubleshooting an Electrical Circuit

### Field Expedient Tester

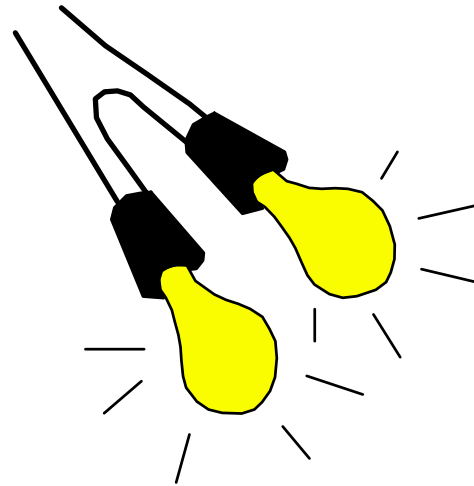

120 or 240 Volts

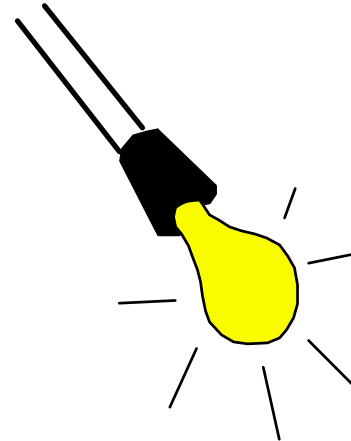

For 120 Volts Only



# TROUBLESHOOT MALFUNCTIONS IN ELECTRICAL CIRCUITS

## Troubleshooting an Electrical Circuit

Multimeter

